

Specialty Doors and Frames



Acoustical



High Definition



Blast and Pressure Resistant



Energy Efficient



Bullet Resistant



Stainable

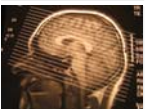

Lead Lined



The Rite Door



Stainless Steel



Severe Weather

E-business

The 'E' stands for easy

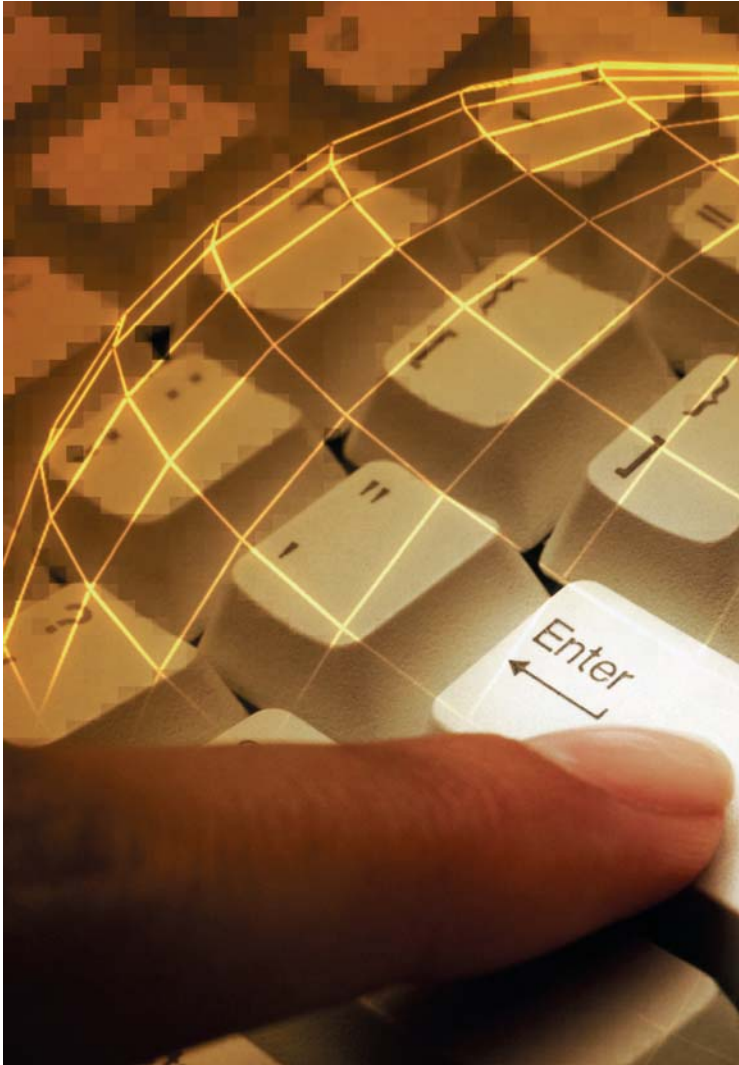

Easy Pricing

Browse pricing on Fleming's entire e-catalogue of standard and custom products.

Easy Ordering

Fleming offers an interactive ordering system for standard and custom doors and frames.

Easy Tracking

E-business tracking allows you online access to the current status of an individual or total order.

E-business allows you to access all that you need to price a product, order a product, or track an order. All you require is a computer and internet access.

Simply visit www.flemingdoor.com and click on the E-business link. The instructions are easy to follow. You may also download technical information, product specifications, fire labelling information and the complete product catalogue.

Fleming E-business means we're open for business anytime you are.

F Fleming
Door Products

ASSA ABLOY

Experience a safer
and more open world

Contents



<i>Acoustical</i>	5
<i>Blast and Pressure Resistant</i>	6
<i>Bullet Resistant</i>	7
<i>Detention Doors</i>	8
<i>Lead Lined</i>	9
<i>Trio Door</i>	10
<i>Trio-E Door</i>	11
<i>F5™ - Tornado Resistant</i>	12
<i>Hurricane Resistant</i>	13
<i>KD Sidelight Frame</i>	14
<i>Vector™ Series Frame</i>	15
<i>High Definition 1-Panel Door</i>	16
<i>High Definition 2-Panel Door</i>	17
<i>Stainline Door</i>	18
<i>The Rite Door®</i>	19
<i>Trimwall</i>	20
<i>Stainless Steel</i>	21
<i>Specialty Designed Frames</i>	22

We're serious about the important role doors and frames have in protecting a building's occupants.

Ask how our products meet the important requirements of these groups:

- | | |
|---|--|
| ANSI American National Standards Institute | FBC Florida Building Commission |
| ASTME American Society for Testing and Materials | GSA General Services Administration |
| ATFP Anti-Terrorism Force Protection | ICC International Code Council |
| CaGBC Canada Green Building Council | PIPITC Petrochemical Industry Standard |
| DHS Department of Homeland Security | UL Underwriters Laboratories |
| DOD Department of Defense | USGBC United States Green Building Council |
| DOE Department of Energy | WHI/ITS Warnock Hersey/ Intertek Testing Services |



U.S. Green Building Council logo is a trademark owned by the U.S. Green Building Council and is used with permission.



Specialty Doors and Frames for Maximum Security, Safety, and Convenience

Product Quality

Fine engineering and manufacturing practices make Fleming doors and frames durable, strong and long lasting.

Brand Recognition

Architects understand their reputation hinges on the products they specify. Fleming is widely specified by architects.

Product Assortment

A comprehensive offering of standard and custom products including stainless steel, green, decorative, detention, sound and energy efficient solutions.

Innovation

Fleming is committed to provide a steady stream of new products. Recent launches include Trio-E, high definition panel designs, bullet resistant, blast resistant, high STC ratings, Vector™ Frames, KD SideLight and more.

Product Features

Fleming adds design features that separate them from other manufacturers such as deep end channels that easily accommodates concealed hardware, high frequency hinge reinforcements and projection welding of all parts.

Lead Times

As a full-line manufacturer, Fleming is second to none for fast delivery and quick ship capabilities. Custom product can ship in 5 days!

Support

Technical support, both online, with in-depth literature, and 24/7 technical support hotline.

Tradition of Excellence

Founding member of CSDMA and NAAMM.



Acoustical Doors and Frames

Key Features and Benefits

Fleming provides a wide selection of operable STC (Sound Transmission Class) doors to its product line. The new Whisper Core Door Systems product offering uses the latest patent pending sound absorbing technology, and includes many options such as, pairs of doors with cylindrical and exit hardware, single doors with rim exit devices, and military/government locks.

Factory installed glazing is available for STC 35-48 ratings using 5/16" thick acoustical glass with Pemko P490 glazing with the acoustical maximum visible glass sizes range from 100 to 720 sq. in.

Whisper Core Door Systems include door, frame and approved seal systems with a certified label. All products have been successfully tested to the required ASTM standards, including ASTM E90, ASTM E1332-90 and ASTM E413. All Whisper Core Doors Systems are in compliance with HMMA 865-03 and CSDMA specifications. No special kerf frames or cam lift hinges are required and all sound seal equipment is included.

Custom engineering allows aesthetic choices to be combined with technical requirements:

- Single flush door systems and factory glazed doors available up to STC 54.
- Flush pairs available up to STC 49.
- 16 or 14 gauge galvanized steel frames.
- 4-1/8" through 14" depths with welded corners.
- ElectroLynx® pre-wired quick connect cable options available.
- cULus or cWHIus positive and neutral pressure ratings available.

Where to Use

- Government facilities including courthouses and interrogation rooms
- Military facilities including BEQ and SCIF rooms
- Healthcare facilities including patient rooms
- Hospitality including guest and meeting rooms
- Educational facilities including classrooms, dormitories and band rooms
- Residential life buildings
- Offices and conference rooms
- Performing arts centers/theatres
- Recording studios
- Stadiums and arenas

Hardwiring Made Easy™





Blast and Pressure Resistant Doors and Frames*

Key Features and Benefits

Providing extra protection against explosions and excessive force, our blast and pressure resistant doors and frames meet or exceed the stringent manufacturing requirements of the Department of Homeland Security and other regulatory groups. The advanced strength and integrity of these openings bring other important benefits: long life, high durability, and maximum corrosion resistance.

Custom engineering allows aesthetic choices to be combined with technical requirements:

- Made for exterior openings and high risk interior areas to resist pressure against a door.
- Certified and third-party tested to meet all nationally required guidelines and legal requirements.
- Pre-engineered products can resist +/-4 psi force (pounds per square inch); impulse load.
- Custom products can resist in upwards of 30 psi force (pounds per square inch) and 80 impulse load, depending on requirements.
- Welded seamless door edge; continuously welded frames.
- Standard 14 gauge, A40 galvalume steel (stainless available).
- ElectroLynx® pre-wired quick connect cable options available.
- cULus positive and neutral pressure ratings available.

Where to Use

- Airports
- Chemical storage areas
- Courthouses
- Embassies
- Government facilities
- Hospitals, e.g., oxygen storage areas
- Laboratories, research areas
- Military facilities
- Petrochemical facilities, refineries, oil rigs
- Pharmaceutical companies
- Police and fire stations



Bullet Resistant Doors and Frames*

Key Features and Benefits

Fortified with ballistic armour that meets or exceeds UL requirements, our bullet resistant doors and frames provide the best protection for threat levels 1 through 8. These openings are designed and built to resist a projectile at maximum velocity. Added benefits are long-term strength and durability, and maximum corrosion resistance.

Custom engineering allows aesthetic choices to be combined with technical requirements:

- Made with a proprietary ballistic armor shield core.
- Non-ricocheting armor UL levels 1-8 (levels 1-3 handguns, levels 4-8 rifles).
- Certified and third-party tested in accordance with UL752 standards.
- Welded seamless door edge; continuously welded frames.
- Standard 14 gauge, A40 galvanized steel (stainless available).
- Hollow metal, wood veneered hollow metal, and solid wood doors available to match any design requirement.
- Bullet resistant glazing available.
- ElectroLynx® pre-wired quick connect cable options available.
- cULus positive and neutral pressure ratings available.

Where to Use

- Airports
- Banks, check-cashing facilities
- Border patrol facilities
- Courthouses
- Police and fire stations
- Post offices
- Toll booths
- Telecommunications facilities

UL 752 Ratings of Bullet Resistant Materials

Note: Maximum velocity is 110% of minimum velocity

Rating	Ammunition	Grain	(g)	Velocity Min. (fps)	Velocity Min. (mps)	No. of Shots
Level 1	9 mm Full Metal Copper Jacket with Lead Core	124	8	1175	358	3
Level 2	.357 Magnum Jacketed Lead Soft Point	158	10.20	1250	381	3
Level 3	.44 Magnum Lead Semi-Wadcutter Gas Checked	240	15.60	1350	411	3
Level 4	.30 Caliber Rifle Lead Core Soft Point	180	11.70	2540	774	1
Level 5	7.62 mm Rifle Lead Core Full Metal Copper Jacket, Military Ball	150	9.70	2750	838	1
Level 6	9 mm Full Metal Copper Jacket with Lead Core	124	8	1400	427	5
Level 7	5.56 Rifle Full Metal Copper Jacket with Lead Core	55	3.56	3080	939	5
Level 8	7.62 mm Rifle Lead Core Full Metal Copper Jacket, Military Ball	150	9.70	2750	838	5
Supplementary Shotgun	12 gauge Rifled Lead Slug	437	28.3	1585	483	3
12 Gauge	00 Lead Buckshot	650	42	1200	366	3



Detention

Key Features and Benefits

All doors and frames are manufactured to meet and exceed all requirements of ANSI/NAAM 863-90 performance criteria for Detention Security hollow metal doors and frames.

- Static load test.
- Rack test.
- Impact load test.
- Removable glazing stop test.
- Doors 2" (50.8mm) thick.
- Fleming "S" Series with face sheets fabricated from A40 galvalume 14 or 12 gauge steel and A40, 14 gauge frames (12 and 10 gauge available).
- Lock and hinge edges continuously reinforced with 12 gauge vertical formed steel stiffener, welded to the interior of both face sheets at 4" (100mm) on centre maximum.
- Door internally reinforced with 18 or 16 gauge continuous vertical top hat steel stiffeners spaced with interior webs no more than 4" (100mm) apart, welded to each face sheet at 6" (150mm) on centre maximum.
- Top hat stiffeners secured together with cULus/cWHIus approved RRPC adhesive, welded at top and bottom and continuously each side, 12" (300mm) from each end.
- Top and bottom of doors reinforced with 12 gauge continuous, inverted, steel end channels, welded to each face sheet at 3" (75mm) on centre maximum and continuously welded to lock and hinge edge vertical formed steel stiffeners.
- Top and bottom of doors reinforced with 12 gauge continuous flush steel, non-removable channels, secured in place with 1" (25mm) welds at 3" (75mm) on centre maximum and continuously welded to face sheets at bevels.
- ElectroLynx® pre-wired quick connect cable options available.
- cULus or cWHIus positive and neutral pressure ratings available.

Where to Use

- Jails
- Prisons
- Remand or detention centres
- Secured areas within hospitals
- Psychiatric institutes
- Court houses

Hardwiring Made Easy™



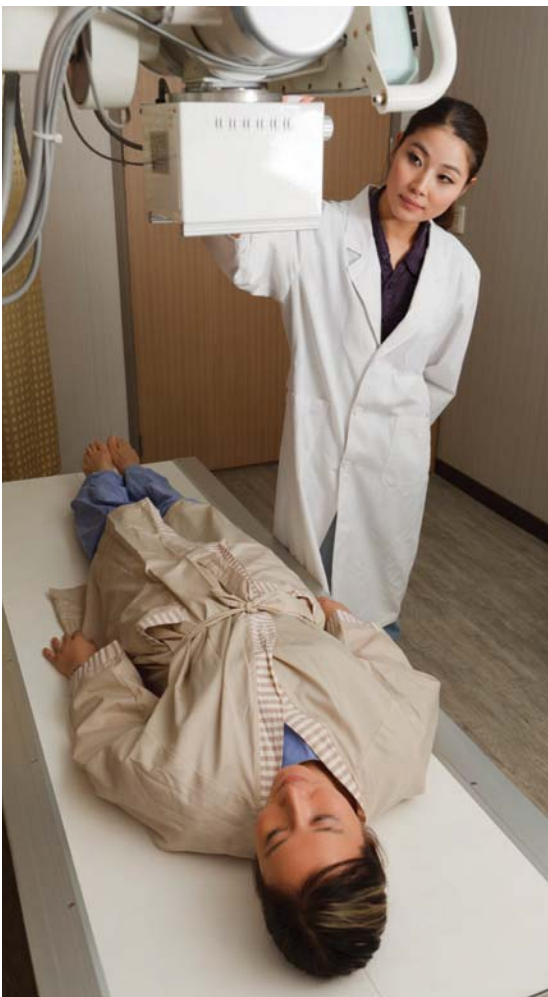

Lead Lined Doors and Frames

Key Features and Benefits

Achieve effective radiation protection with our full line of high quality lead lined doors and frames. These openings accomplish the important task of reliably containing radiation in sensitive areas.

Custom engineering allows aesthetic choices to be combined with technical requirements:

- Lead sheets, available in 1/32" to 1/2" thickness, integrated into door and frame for strength and vandal resistance.
- Vertically steel stiffened doors for added strength and durability.
- Standard 1-3/4" thick doors accommodate standard hardware.
- Continuously welded, seamless door edge; continuously welded and lead lined frame.
- Standard 16 gauge steel; 18-12 gauge available.
- Standard A40 galvaneal steel (stainless available).
- Wood veneered hollow metal doors available to match most design requirements.
- ElectroLynx® pre-wired quick connect cable options available.
- cULus or cWHIus positive and neutral pressure ratings available.

Where to Use

- Aerospace facilities - microwave transmission rooms
- Airports
- Defense, military, and security environments
- Healthcare - X-ray and imaging rooms
- Medical schools
- Nuclear power plants



Trio Door

Key Features and Benefits

Strong, Beautiful, and Green best describe Trio, the innovative new product from Fleming. Trio is a fusion of laminate and welded steel stiffener cores to create a new patent pending design like no other. Trio contains all of the aesthetic and insulating benefits of a Fleming polyurethane door with the strength of welded steel stiffeners.

Custom engineering allows aesthetic choices to be combined with technical requirements.

- 18 gauge face sheets, 16 and 14 gauge optional.
- 16 gauge inverted end channels welded to both face sheets for added strength.
- 14 gauge closer reinforcement.
- 18 gauge face sheets plus 22 gauge core plate is effectively 14 gauge thick on threat side door.
- 22 gauge steel stiffeners spaced 6" apart and welded to core plate 5" on centre.
- Steel stiffened laminated core for added strength and durability.
- 30% less thermal bow than most polyurethane foam core doors.
- No marks from stiffeners on door face sheets.
- Many different door designs and colour options available.
- High recycled steel content for LEED points up to 57.1%.
- Injected polyurethane foam performs 40% better than competitive steel stiffened doors
- Physical endurance testing: Meets ANSI A250.4 performance test, Level A (1,000,000 cycles) class 1 stiffness.
- ElectroLynx® pre-wired quick connect cable options available.
- cULus or cWHIus positive and neutral pressure ratings available.

Where to Use

- Exterior openings
- Openings separating temperature change

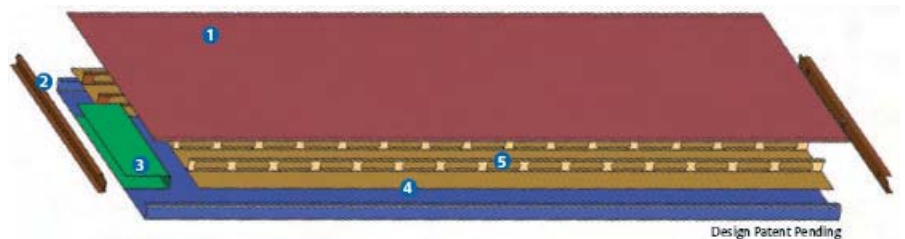

Hardwiring Made Easy™



Energy Efficient





Trio-E Energy Efficient Steel Stiffened Door

Key Features and Benefits

Approximately 40% of all energy leakage comes from the building envelope* this includes exterior doorways. Trio-E doors installed with Fleming thermally broken frames and Pemko thermal thresholds help increase thermal retention and reduce energy leakage.

Trio-E is a new patent pending door design that delivers superior insulated values and strength plus, provides aesthetic qualities desired in today's commercial building applications. The "E" is for energy efficiency and Trio-E has the lowest U-Factor (0.29) for a steel stiffened door in the market today. The U-Factor of 0.29, R-Value 3.4 was achieved in an operable condition (ASTM C1363). The Trio-E will provide years of strength and sustainable energy savings for any building.

*Tony Woods, Air Tight Buildings, 2005

- 18 gauge face sheets, 16 gauge optional.
- 16 gauge inverted end channels welded to both face sheets for added strength.
- 14 gauge closer reinforcement.
- 22 gauge steel stiffeners spaced every 6" apart with injected polyurethane foam.
- 7 gauge steel hinge reinforcements.
- 4'0" x 8'0" Maximum single.
- 8'0" x 8'0" Maximum pair.
- Less thermal bow than conventional steel stiffened doors
- Physical endurance testing: Meets ANSI A250.4 performance test, Level A (1,000,000 cycles).
- Mechanically interlocked, hemmed vertical edge seams.
- Seamless edges available.
- Reinforcing for most lock preps, including concealed hardware.
- ElectroLynx® pre-wired quick connect cable options available.
- cULus or cWHIus positive and neutral pressure ratings available.

Where to Use

- Exterior openings
- Openings separating temperature change





Tornado Resistant - F5™

Key Features and Benefits

Created specifically for community shelters and safe room applications, the Fleming F5™ Severe Weather System has been manufactured and tested to exceed all FEMA 361 performance standards. With tests ranging from a 100 mph missile impacts to wind load and vacuum pressures exceeding 1.75 psi, you can rest assured that when really bad weather comes knocking, the F5™ has what it takes to safely weather the storm.

- Heavy-duty 14 gauge galvanized steel construction.
- Reinforced with 12 gauge lock edge channels.
- Fully welded edge seams.
- Welded flush top and bottom galvanized steel channels.
- 2# density foamed-in-place polyurethane core.
- Heavy-duty 14 gauge galvanized steel frame.
- Reinforced hardware application.
- Supplied with masonry wall anchors.
- 3-heavyweight hinges.
- Reinforced for closer application.
- ElectroLynx® pre-wired quick connect cable options available.
- cULus or cWHIus positive and neutral pressure ratings available.

Where to Use

- Tornado prone regions of North America
- Residential safe rooms
- Community shelters in schools, hospitals, armories, commercial buildings and industrial facilities
- Enhanced protection areas

Hardwiring Made Easy®





Hurricane Resistant

Key Features and Benefits

Fleming's FBC FL14237 approved, UL labelled windstorm products have been engineered, independently tested, certified and labelled to the impact, structural, air and water infiltration standards for hurricane-resistant exterior openings. This is in accordance with the mandate by the 2007 Florida Building Code, including the HVHZ and the ICC.

- 14, 16, 18 and 20 gauge doors.
- Honeycomb, polystyrene or vertically stiffened cores.
- Standard A40 galvaneal steel (G90 galvanized and stainless available).
- Flush, embossed or glazed.
- Factory labelled under UL file ZHCW.R8930.
- Standard 16 gauge A40 galvaneal steel knock down or welded frames.
- Standard 16 gauge A40 galvaneal steel transom, sidelight and window frames (glazed and/or panelled).
- 14 or 12 gauge available.
- G90 galvanized and stainless available.
- Wood/steel stud, existing masonry/concrete and structural steel wall anchorage.
- Factory labelled under UL file ZHDL.R8931.
- Out-swing; 4'x8' singles, 8'x8' pairs.
- In-swing; 3'x7' singles.
- 350 ft lbs impact resistant.
- +/- 70 psf maximum designed load.
- May be used with any builders' hardware having an FBC or NOA component approval within their approved limits.
- ElectroLynx® pre-wired quick connect cable options available.
- cULus or cWHIus positive and neutral pressure ratings available.

Where to Use

- Hurricane-prone areas
- HVHZ (Miami-Dade and Broward Counties, FL)
- Outside the HVHZ (2007 Florida Building Code)
- Outside Florida - ICC

Hardwiring Made Easy™





KD Sidelight Frame

Key Features and Benefits

A common problem with the installation of a sidelight frame is moving the assembled frame unit to the opening. Fleming is pleased to provide the KD SideLight frame. This is a drywall sidelight unit that can be assembled and installed at the opening without having to weld the frame pieces together and transport them to various levels of a building. There are no more concerns of fitting the welded frame in the elevator or through doorways of a building.

The rough opening height equals the finished opening height +1"
The rough opening width equals the finished width +2"

- Uses common hand tools for installation.
- Installs into a rough opening in minutes.
- Complete frame bundle can be carried saving both labour and transportation cost.
- 4'0" x 8'0" Maximum door opening.
- 8'0" x 8'0" Maximum elevation opening.
- Drywall profile.
- 16 gauge galvalume steel.
- 2" face standard, 1-1/2" and 1-3/4" available.
- Sill faces available: 1-1/2" through 6".
- Jamb Depths:
 - Unequal rabbet: 4-1/2" through 8-3/4"
 - Equal rabbet: 4-7/8" through 8-3/4"
- Non fire rated.

Where to Use

- Offices
- Retrofit applications

Vector™ Series

Key Features and Benefits

The Vector™ Series line of steel door frames. Manufactured from paintable galvalume to rigid commercial specifications including UL fire rating, they feature an embossed linear design to give your commercial door frames a decorative accent while maintaining the frames structural integrity. The Vector™ Series features two distinctive standard designs, with custom designs available.

- Available for both masonry and drywall applications.
- Manufactured from 16 gauge paintable galvalume steel.
- 4 point tabbing system.
- Perforated “break-away” tabs for stronger back welding of frames.
- 10 gauge high frequency hinge reinforcing at all locations.
- Convertible hinge reinforcing for standard or heavyweight hinges.
- 1 piece integral strike reinforcing/dust box.
- Compatible with most hardware preparations.
- ElectroLynx® pre-wired quick connect cable options available.
- cULus or cWHIus positive and neutral pressure ratings available.



Where to Use

- Office buildings
- Hotels
- Condos/apartments

Hardwiring Made Easy®





High Definition 1-Panel Embossed Doors

Key Features and Benefits

Fleming's HD 1-Panel Door features a distinct high definition embossed design. This design makes a grand impression and adds elegance and sophistication to any room or entrance. Underneath the exterior skins is an energy efficient polystyrene core making this door an important solution to today's building requirements. Design, durability, and energy efficiency makes the Fleming HD 1-Panel door a cost effective alternative to stile and rail wood doors. Custom engineering allows aesthetic choices to be combined with technical requirements:

- 20 & 18 gauge galvaneal face sheets.
- 2868, 2870, 3068, 3070 and 3080 available sizes.
- Energy efficient polystyrene core provides total surface support, impact-resistant and exceptional thermal resistance.
- Commercial grade reinforcing for most common lock preps including concealed hardware.
- Standard 10 gauge high-frequency steel hinge reinforcements.
- End channels and closer reinforcements.
- Mechanically interlocked seamed edges are standard with optional seamless edges.
- Thermal insulation: Polystyrene core values U-Factor 0.31, R-Value 3.2 (ASTM C1363).
- Physical endurance testing: Meets ANSI A250.4 performance test, Level A (1,000,000 cycles).
- ElectroLynx® pre-wired quick connect cable options available.
- cULus or cWHIus positive and neutral pressure ratings available.

Where to Use

- Perfect for condominiums
- Assisted living complexes
- Multi-family entrances
- Hotels
- Office buildings
- Dormitory complexes

High Definition 1-Panel Embossed Design

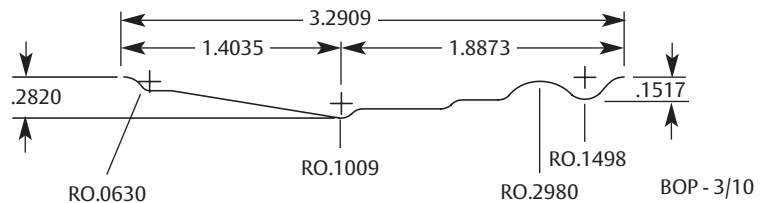



High Definition 2-Panel Embossed Doors

Key Features and Benefits

Fleming's HD 2-Panel Doors feature a distinct high definition embossed surface and are offered in three architectural designs: 2-Panel, Arch Top 2-Panel and Plank Arch Top 2-Panel. Custom engineering allows aesthetic choices to be combined with technical requirements:

- 20 & 18 gauge galvalume face sheets.
- 2868, 2870, 3068, 3070 and 3080 available sizes.
- Energy efficient polystyrene core provides total surface support, impact-resistant and exceptional thermal resistance.
- Commercial grade reinforcing for most common lock preps including concealed hardware.
- Standard 10 gauge high-frequency steel hinge reinforcements.
- End channels and closer reinforcements.
- Mechanically interlocked seamed edges are standard with optional seamless edges.
- Thermal insulation: Polystyrene core values U-Factor 0.31, R-Value 3.2 (ASTM C1363).
- Physical endurance testing: Meets ANSI A250.4 performance test, Level A (1,000,000 cycles).
- ElectroLynx® pre-wired quick connect cable options available.
- cULus or cWHIus positive and neutral pressure ratings available.

Where to Use

- Condominiums
- Assisted living complexes
- Multi-family entrances
- Hotels
- Office buildings

High Definition 2-Panel Embossed Doors

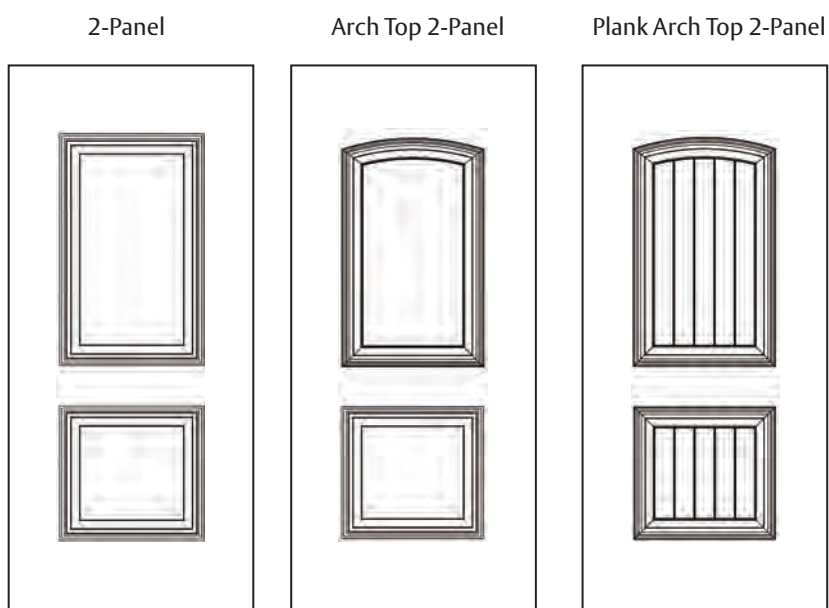



Stainline - Stainable Woodgrained Steel Doors

Key Features and Benefits

Constructed with continuous hinge and lock channel construction the full height of the door. Hinge and lock mounting preparations integrally form into these channels.

Inverted top and bottom channel construction provides a full perimeter channel door infrastructure with door face skins supported by either polystyrene core or polyurethane core permanently bonded to the face skins as required for insulating values on all openings.

- Door face skins are grained .005" deep to accent the colour.
- Available factory stained and sealed with the owner's choice of Fleming standard colours.
- 20 gauge or 18 gauge galvalume steel for corrosion resistance.
- Flush and 6 panel design.
- ElectroLynx® pre-wired quick connect cable options available.
- cULus or cWHIus positive and neutral pressure ratings available.

Where to Use

- Offices
- Condominiums/apartments
- Hospitals



Cabernet



Cashew



Cocoa



Java



Natural



Wheat



The Rite Door® Integrated Door Assemblies

Key Features and Benefits

With a generous range of colors, finishes and options the RITE Door® by Adams Rite will change the way you look at fire doors forever. It blends completely into the architecture or makes its own design statement with its wide range of colors, textures and finishes.

Versatile, durable and cost effective.

- Reduced field installation time and labour cost.
- Eliminates fire inspection problems.
- Perfect alignment and operation (order with compatible frame).

Door Types

- 18 & 16 gauge honeycomb core.
- 18 & 16 gauge steel stiffened core.
- 18 & 16 gauge temperature rise core (14 gauge available on request).

Finishes

- Prime coat.
- Galvanneal (A40).
- Prefinished paint.
- High pressure laminate (applied to faces only).

Fire Rating

Door, frame & hardware listings comply with UBC 7.2-97 (UL10C) positive pressure requirements up to 3 hours.

Where to Use

- Office buildings
- Laboratories
- Warehouses
- Computer rooms
- Clean rooms
- Cross corridor doors
- Smoke doors
- Stairwell doors
- Elevator lobby
- Doors with automatic operators
- Doors with access control

Trimwall- A40 Paintable Galvanneal

Key Features and Benefits

Fleming's Trimwall is sleek and beautiful. The 5/8" face is an alternative to the standard 2" face standard commercial design. Trimwall sidelights provide office separations while allowing maximum light to pass through the partitions.

- Available for both masonry and drywall applications.
- Manufactured from 18 gauge paintable galvanneal steel.
- Factory welded.
- 5/8" face.
- 3/16" wide soffit.
- 3 1/2" to 6" jamb depth.

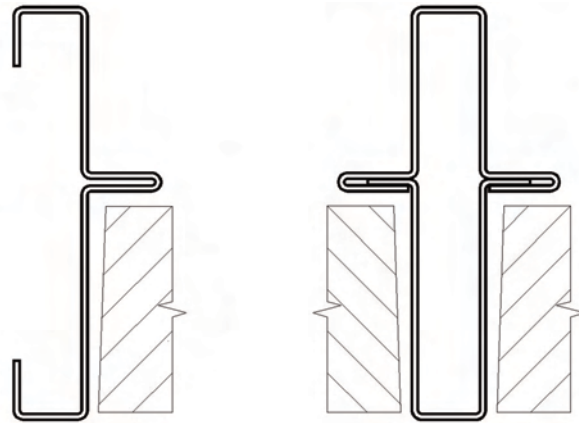
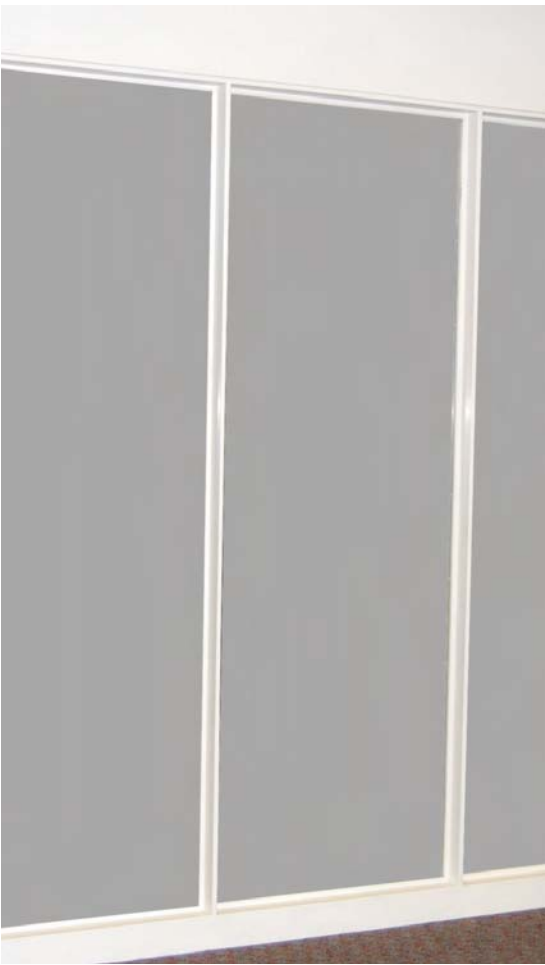

Where to Use

- Offices
- Hotels

Stainless Steel Doors and Frames

Key Features and Benefits

Sleek and beautiful stainless steel doors and frames offer an important practical feature for many building owners: corrosion resistance. Our stainless steel product line is the ideal solution for clean room environments and areas susceptible to moisture, while also providing significant safety and security.

Custom engineering allows aesthetic choices to be combined with technical requirements:

- Type 304 and 316 available.
- Easy to maintain; long-term strength and durability.
- Water tight/sanitary design available.
- Continuously seamless welded door edge (key for corrosive environments); seamless top and bottom option.
- Standard 16 gauge steel; 14 and 12 gauge available.
- Lites and louvers optional.
- Any commercial finish (#2B matte, #4 brushed, and #8 mirrored).
- Meets CSDMA 08 11 19 - 2009 and ANSI/NAAMM HMMA 866-11.
- ElectroLynx® pre-wired quick connect cable options available.
- cULus or cWHIus positive and neutral pressure ratings available.



Where to Use

Corrosive environments

- Clean room environments
- Food processing plants
- Hospitals
- Laboratories
- Marine areas, piers, berths
- Swimming pool areas
- Waste water treatment plants
- Chemical manufacturing facilities

Clean room environments

- Hospitals
- Computer chip manufacturing areas
- Data centres
- Pharmaceutical, bio-chemical

Highly-stylized environments

- Casinos
- Hotel lobbies
- Museums
- Office buildings

Specialty Designed Frames

Key Features and Benefits

Architects frequently push the envelope of design to enhance the beauty of a building. Fleming's design team has the ability to take that design and turn it into a work of art for your building. This allows the opening to be functional and aesthetically-pleasing.

- Special profiles.
- Arched tops.
- Round windows.
- Gothic arches.
- Segmented frames in plan.
- ElectroLynx® pre-wired quick connect cable options available.
- cULus or cWHIus positive and neutral pressure ratings available.



Where to Use

- Offices
- Hotels
- Places of worship



You can almost guarantee a steel door is going to rust. We guarantee ours won't.

Galvanneal steel is the specified material of choice for most construction products because, unlike primed cold rolled steel, it will not rust.

All Fleming doors and frames are manufactured from A40 Paintable Galvanneal. The zinc-iron alloy penetrates the steel for an integral, uniform protection that prevents rusting inside and out.

State-of-the-art technology used to chromate and phosphate treat the steel provides an excellent substrate for finish painting and lasting paint adhesion.

The ASSA ABLOY Group is the global leader in access solutions. Every day, we help billions of people experience a more open world.

ASSA ABLOY Opening Solutions leads the development within door openings and products for access solutions in homes, businesses and institutions. Our offering includes doors, frames, door and window hardware, locks, perimeter fencing, access control and service.



Fleming Door Products
101 Ashbridge Circle
Woodbridge, Ontario Canada
L4L 3R5

Phone: 416.749.2111
Toll Free: 800.263.7515
Fax: 905.851.8346
www.flemingdoor.com

Fleming is a brand associated with ASSA ABLOY of Canada Ltd., an ASSA ABLOY Group company.
Copyright© 2011, ASSA ABLOY of Canada Ltd. All rights reserved. Reproduction in whole or in part without the express written permission of ASSA ABLOY is prohibited.



U.S. Green Building Council logo is a trademark owned by the U.S. Green Building Council and is used with permission.