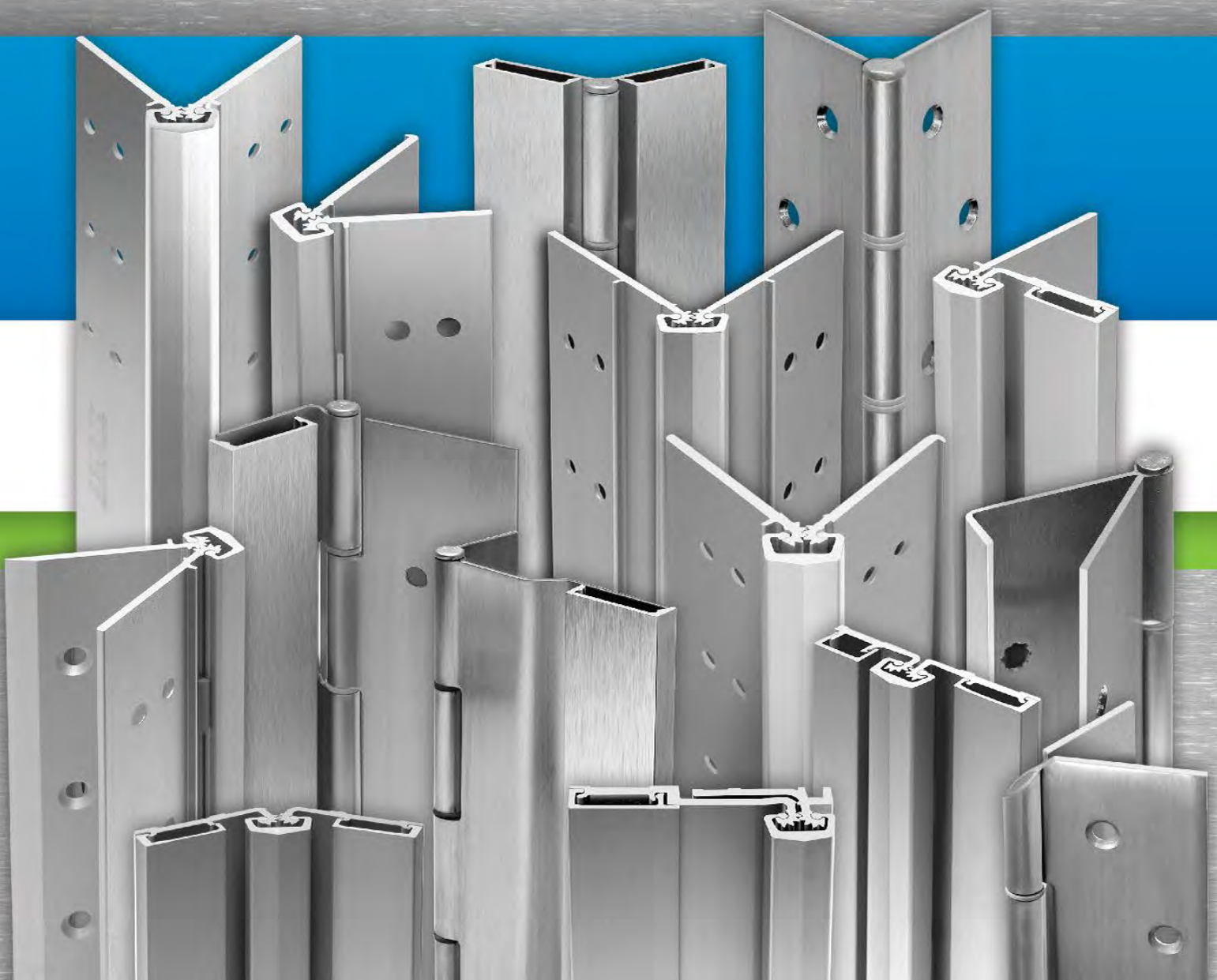




SELECT HINGES™

ALUMINUM GEARED CONTINUOUS HINGES
STAINLESS STEEL PIN & BARREL CONTINUOUS HINGES





SELECT HINGES™

3258 Stadium Park Way
Kalamazoo, MI 49009
800-423-1174
Fax 800-423-7107
www.select-hinges.com

CONTINUOUS HINGES FOR:

- New construction
- Retrofit/door repairs
- High traffic doors
- Wide doors
- Extra heavy doors
- Replacing butt and pivot hinges

SEND QUOTE REQUESTS AND ORDERS TO:

- FAX: 1-800-423-7107
- EMAIL: customerservice@select-hinges.com

**GEARED
CONTINUOUS
HINGES**

**PIN & BARREL
CONTINUOUS
HINGES**

**TOILET PARTITION
CONTINUOUS
HINGES**

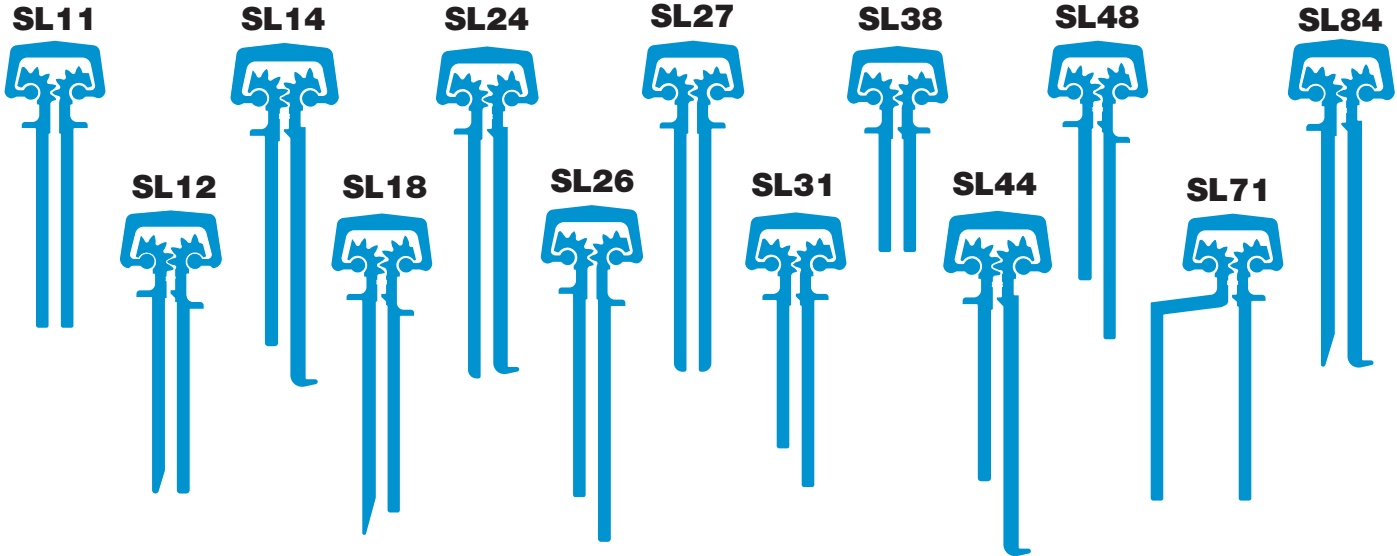
LATCH GUARDS

**ELECTRIC PREPS
& ACCESSORIES**

**NON-ELECTRIC
HINGE PREPS**

ACCESSORIES

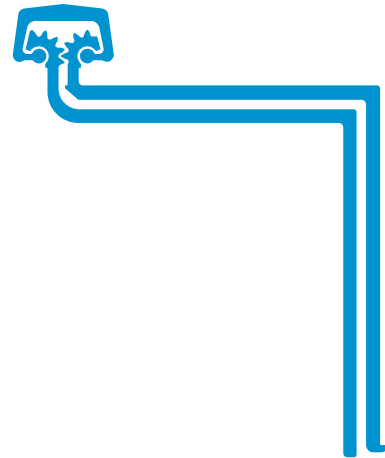
Concealed



Wide Throw **SL40**

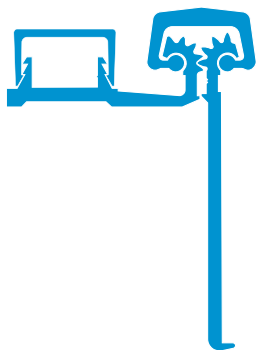


Swing Clear **SL41**



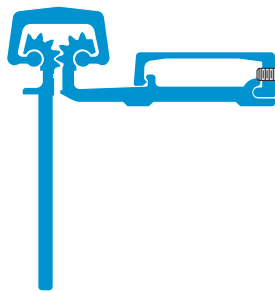
Half Mortise

SL52

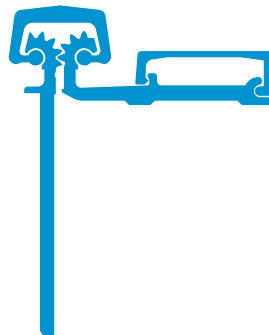


Half Surface

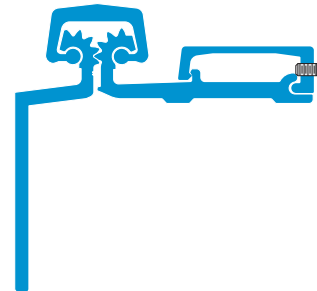
SL53



SL54



SL77



Full Surface

SL21



SL57



GEARED CONTINUOUS HINGES



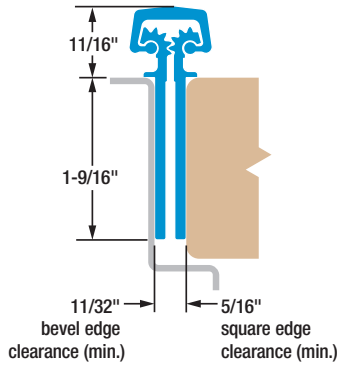
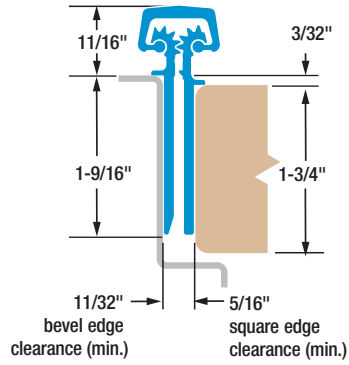
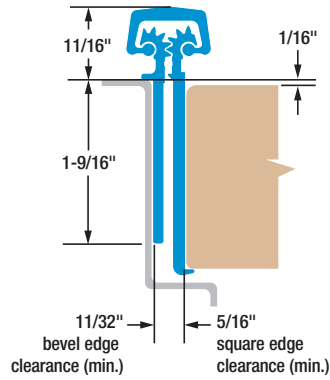
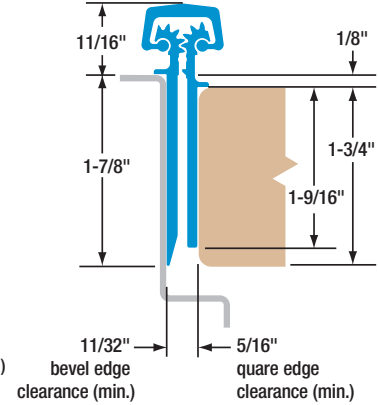
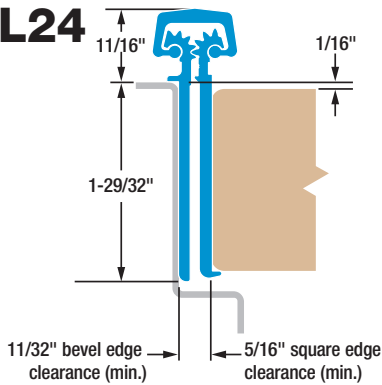
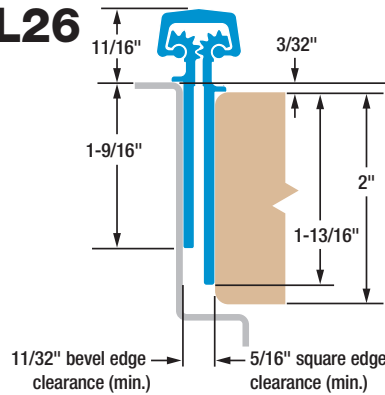
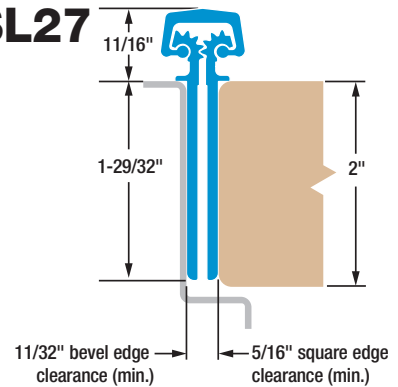
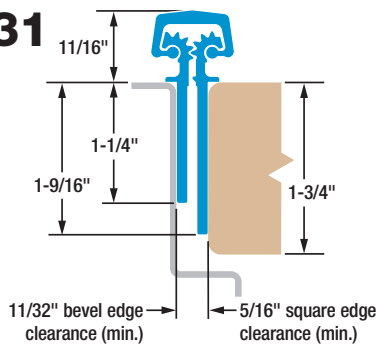
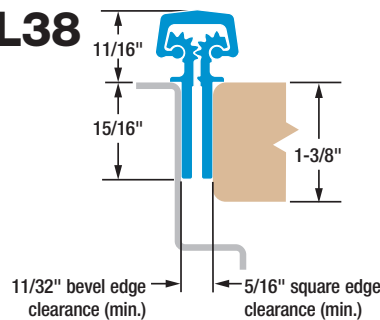
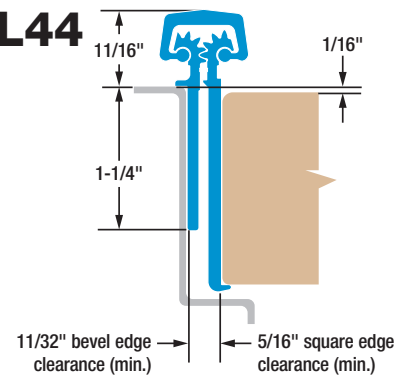
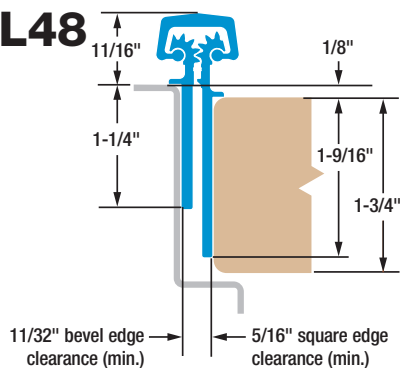
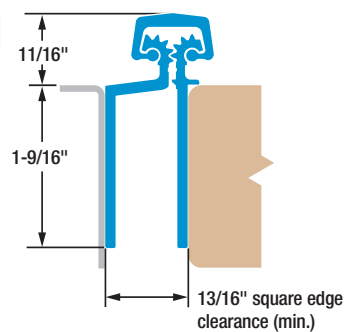
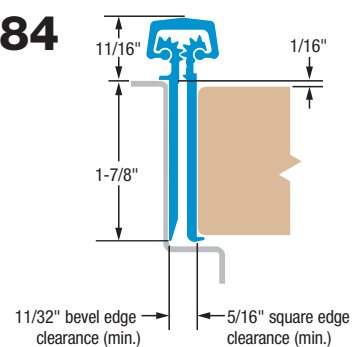
PART NUMBER INTERCHANGE

SELECT MODELS	NGP	ROTON	PEMKO	STANLEY	ABH	PBB	IVES
SL11 HD300		780-112	FMSLF/KFM	661			
SL11 HD600	HD1100	780-112HD	FMSLFHD/KFMHD	661HD	A110HD	CG31	112HD/112XY
SL11 LL	HD1100-LL	780-112LL			A110LL		
SL12 HD600							
SL14 HD300							
SL14 HD600	HD1400	780-124HD		669HD			114XY
SL18 HD300		780-111	FMSLI		A111HD		
SL18 HD600	HD1800	780-111HD	FMSLIHD	671HD	A120HD	CG31I	
SL18 LL	HD1800-LL	780-111LL		671HDLL	A120LL		
SL21 HD300		780-210	FS				
SL21 HD600	HD2100	780-210HD	FSHD	665HD	A210HD	CG33C	210XY**
SL24 HD300		780-224	FM				
SL24 HD600	HD2400	780-224HD	FMHD	662HD	A240HD	CH31	224HD/224XY
SL24 LL	HD2400-LL	780-224LL		662HDLL	A240LL		
SL26 LL				672HDLL	A260LL	CG31PN	026XY
SL27 LL	HD2700-LL	780-226LL		673HDLL	A270LL	CG31P	027XY
SL31 HD600			SPFMSLF				
SL38 HD300		780-110HD					
SL40 HD600		780-235HD	WTFMHD	661HDWT	A110WT		040XY
SL41 HD600	HD4100	780-041HD	OFSM	674HD	A410HD	CG31C	
SL41 LL	HD4100-LL	780-041LL			A410LL		
SL44 HD600			SPFM				
SL48 HD600			SPFMSLI				
SL52 HD600			HMHD				
SL53 HD600	HD5300	780-053HD		679HD	A530HD	CG34N	053XY**
SL54 HD600	HD5400	780-054HD	HSHD	663HD	A540HD	CG34	054XY**
SL57 HD300		780-157	FSCP	664			
SL57 HD600	HD5700	780-157HD	FSCPHD	664HD	A570HD	CG33N	157XY**
SL71 HD600		780-113HD*	FMSLISFHD*	668HD*	A130HD*		
SL77 HD600		780-155HD	HSSFHD	680HD	550HD		
SL84 HD600							
SL84 LL							
SL60/62							

* Not equivalent hinge but possible SELECT hinge substitution depending on application.

** Compatible with inset & profile.

No equivalent hinge available from this manufacturer.

SL11

SL12

SL14

SL18

SL24

SL26

SL27

SL31

SL38

SL44

SL48

SL71

SL84


CONCEALED GEARED CONTINUOUS HINGES



PART NUMBER INTERCHANGE: CONCEALED

SELECT MODELS	NGP	ROTON	PEMKO	STANLEY	ABH	PBB	IVES
SL11 HD300		780-112	FMSLF/KFM	661			
SL11 HD600	HD1100	780-112HD	FMSLFHD/KFMHD	661HD	A110HD	CG31	112HD/112XY
SL11 LL	HD1100-LL	780-112LL			A110LL		
SL12 HD600							
SL14 HD300							
SL14 HD600	HD1400	780-124HD		669HD			114XY
SL18 HD300		780-111	FMSLI		A111HD		
SL18 HD600	HD1800	780-111HD	FMSLIHD	671HD	A120HD	CG31I	
SL18 LL	HD1800-LL	780-111LL		671HDLL	A120LL		
SL24 HD300		780-224	FM				
SL24 HD600	HD2400	780-224HD	FMHD	662HD	A240HD	CH31	224HD/224XY
SL24 LL	HD2400-LL	780-224LL		662HDLL	A240LL		
SL26 LL				672HDLL	A260LL	CG31PN	026XY
SL27 LL	HD2700-LL	780-226LL		673HDLL	A270LL	CG31P	027XY
SL31 HD600			SPFMSLF				
SL38 HD300		780-110HD					
SL44 HD600			SPFM				
SL48 HD600			SPFMSLI				
SL71 HD600		780-113HD*	FMSLISFHD*	668HD*	A130HD*		
SL84 HD600							
SL84 LL							

* Not equivalent hinge but possible SELECT hinge substitution depending on application.

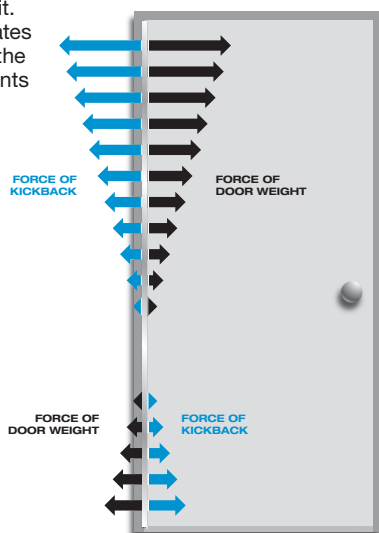
** Compatible with inset & profile.

No equivalent hinge available from this manufacturer.

HINGE STRESS COMPARISON

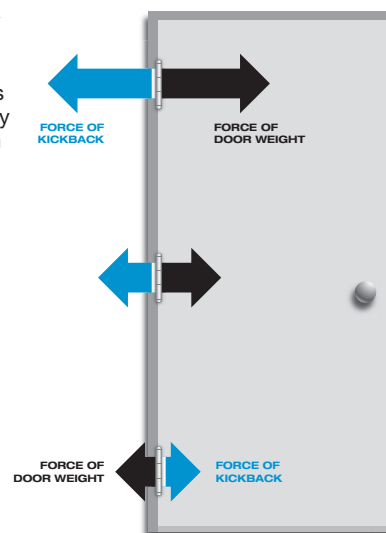
CONTINUOUS HINGES

SELECT continuous hinges unite the door and frame into an integrated, sag-free unit. "Kickback" energy dissipates along the entire length of the door and frame and prevents hinge failure.



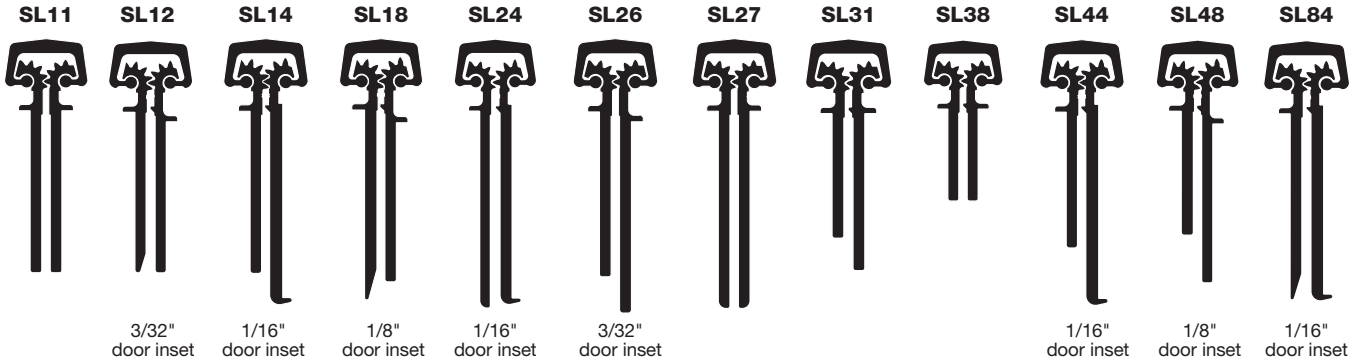
CONVENTIONAL BUTT HINGES

On conventional hinges, opening and "kickback" energy from closers and automatic operators concentrates on the top butt hinge. This force works against the top hinge, eventually forcing it apart or pulling it from the frame/door.





Concealed Geared Continuous Hinges



Door Clearances

For Square and Beveled-Edge Doors

IMPORTANT: All uncut concealed hinges are non-handed and templated. Models SL11, SL27 and SL38 remain non-handed after cutting. All other concealed hinges become handed after cutting.

* **NOTE:** Refer to NFPA 80 manual for clearance requirements on fire-rated entrances.

Important Warranty Information:

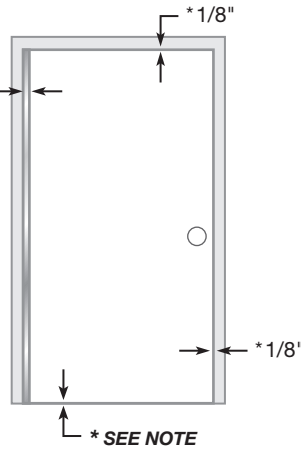
The following actions will void any warranty, expressed or implied:

- Failure to install the hinge according to manufacturer's specifications and requirements. (For more information, visit selecthingerequirements.com.)
- Use of fasteners other than those supplied with the hinge.
- Unauthorized field modifications, including alteration or removal of the factory-applied lubricant, altering the original finish or painting the hinge.

Single Door

Hinge side clearance

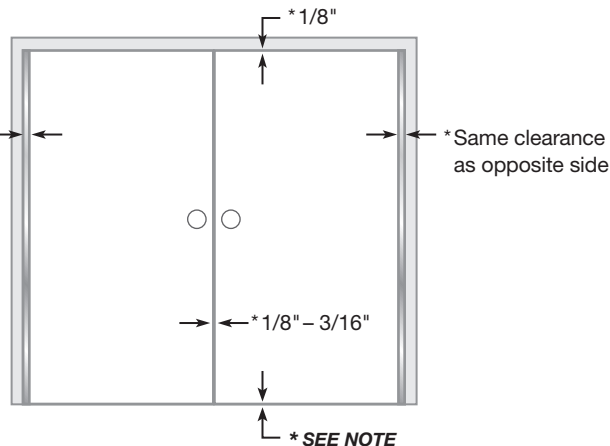
Square Edge	* 5/16"
Beveled Edge	* 11/32"



Double Doors (Pair)

Hinge side clearance

Square Edge	* 5/16"
Beveled Edge	* 11/32"



Tools Needed

- Metal-cutting saw
- Tape measure
- #13 or 3/16" drill bit
- 5/32" drill bit (wood frames/doors)
- #3 Phillips drive
- Shims

Parts Supplied

- #12-24 self-drilling, thread-forming (SDTF) 410 SS Phillips undercut flathead screws

Optional Parts

- #12 410 SS Phillips undercut flathead wood screws
- #12-24 thread-forming (TF) 410 SS Phillips undercut flathead screws
- Protective gloves are recommended

How to Cut the Hinge to Fit

- A. Keep hinge in "door closed" position (Fig. 1).
- B. Determine whether this will be a right-hand or left-hand installation.

IMPORTANT: Cut only one end of hinge. Cut end will be installed at the bottom. Keep original templated six-hole pattern at top end of hinge.

NOTE: SL11, SL27 and SL38 are non-handed and remain non-handed after cutting.

- C. Using a metal-cutting saw, begin the cut through the gear cap first.

NOTE: DO NOT cut through a set screw bearing.

- D. Reinstall any set screw bearing that may have been cut off.

A. Prepare Frame

1. Shim hinge to 1/8" below the header to allow for door clearance.
2. Hold hinge in "door open" position (Fig. 2), making sure frame leaf alignment flange is tight against frame face.

3. Mark (or centerpunch) hole locations.

NOTE: TF screws and wood screws require pilot holes at marked locations. SDTF screws do not require pilot holes.

4. If using SDTF screws, go to Step 5. If using TF or wood screws, drill holes at marked locations. DO NOT attach hinge to the frame at this time.

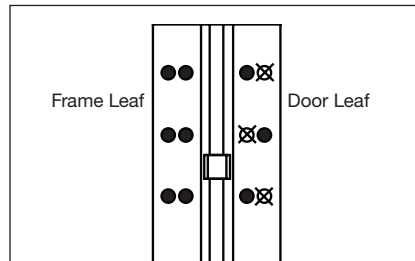
- Metal frame: Use #13 (.185") bit or 3/16" (.188") bit
- Wood frame: Use 5/32" (.156") bit

B. Attach Door to Hinge

5. Align the door leaf alignment flange or the door leaf lip along full length of door edge (even if door is slightly warped).

IMPORTANT: Top end of the hinge must be flush with the top of the door.

IMPORTANT: If installing hinge on a 90-minute fire-rated wood door, mark or centerpunch only one hole in each pair of holes at the top and bottom of the door leaf. DO NOT install remaining screws in the six-hole pattern on the door leaf. See illustration below.



6. Mark (or centerpunch) holes. If using SDTF screws, go to Step 7. If using TF or wood screws, drill holes at marked locations.

- Metal door: Use #13 (.185") bit or 3/16" (.188") bit

- Wood door: Use 5/32" (.156") bit

7. Fasten door leaf to door using #3 Phillips drive and fasteners provided.

C. Attach Door to Frame

8. Position door at 90 degrees to the frame. Shim door to the proper height so the door aligns with the top screw holes.
9. Install two screws at the top of hinge. Remove shim and align remaining holes. Install screws in middle and bottom two holes.
10. Check door for proper swing and clearance before installing remaining screws.

Reinforcing & Rivnuts®

No hinge reinforcement is necessary except on extremely high-frequency, extremely tall, extremely heavy or extra-wide doors. Rivnuts are recommended for use in the frame and door when the door exceeds 450 lb.

NOTE: Only SELECT steel Rivnuts are to be used with fire-rated SELECT hinges.

Grouted/Slushed-in Frames

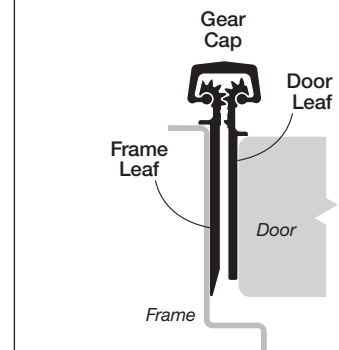
For ease of installation, it is recommended some sort of mudguard be installed behind the frame. Do not use self-drilling, thread-forming (SDTF) screws to drill into grouted frames. If mudguards have not been used, carefully drill pilot holes through frame and remove grout for screw clearance. Do not oversize holes in frame.

Fire-Rated Hinges

All SELECT hinges (except SL71, SL77 and Toilet Partition hinges) are 90-minute UL-rated, without fire pins or studs. Please contact SELECT for complete information about its fire-rated hinges.

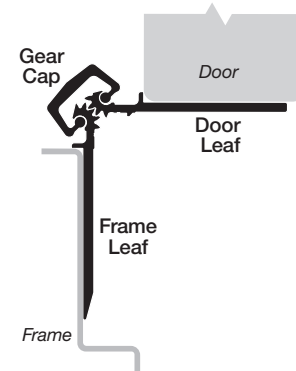


Fig. 1 Door Closed Position



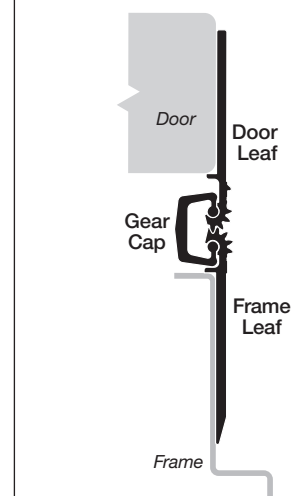
Model SL18 shown

Fig. 2 Door Open 90°

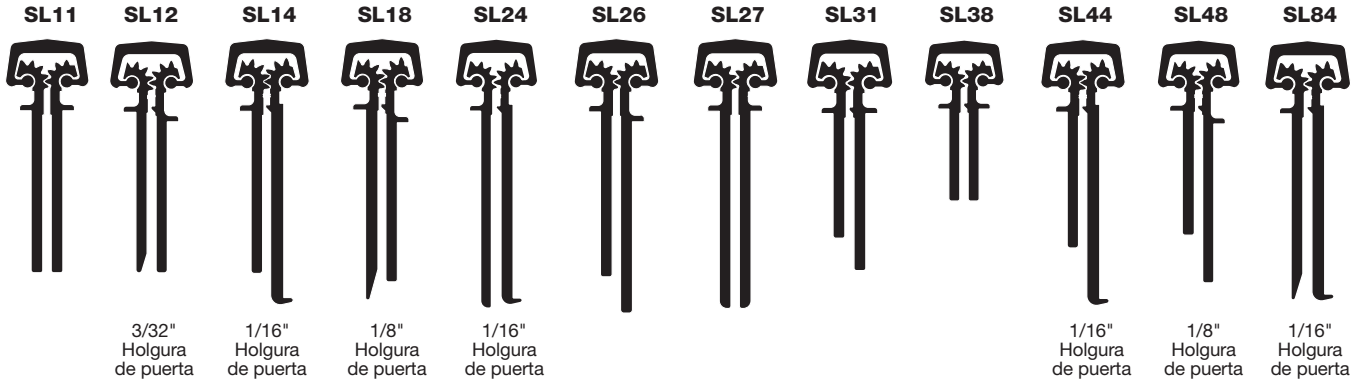


Model SL18 shown

Fig. 3 Door Open 180°



Model SL18 shown



Espacios libres de puerta

Para puertas de borde cuadrado y de borde biselado

IMPORTANTE: Todas las bisagras ocultas sin cortar son invertibles y con plantilla. Los modelos SL11, SL27 y SL38 se mantienen invertibles después del corte. El resto de las bisagras ocultas se vuelven no invertibles después del corte.

* **NOTA:** Consulte el manual de NFPA 80 para ver los requisitos de espacio libre en las entradas con clasificación ignífuga.

Información importante sobre la garantía:

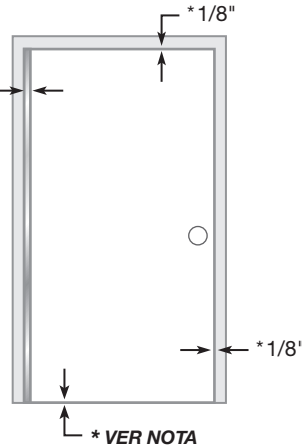
Las acciones siguientes invalidarán cualquier garantía, ya sea explícita o implícita:

- No instalar la bisagra siguiendo las especificaciones y requisitos del fabricante. (Visite selecthingerequirements.com para obtener más información)
- Usar sujetadores que no sean los que se suministran con la bisagra.
- Modificaciones de terreno no autorizadas, como alterar o retirar el lubricante aplicado en la fábrica, alterar el acabado original o pintar la bisagra.

Puerta simple

Espacio libre en lado de bisagra

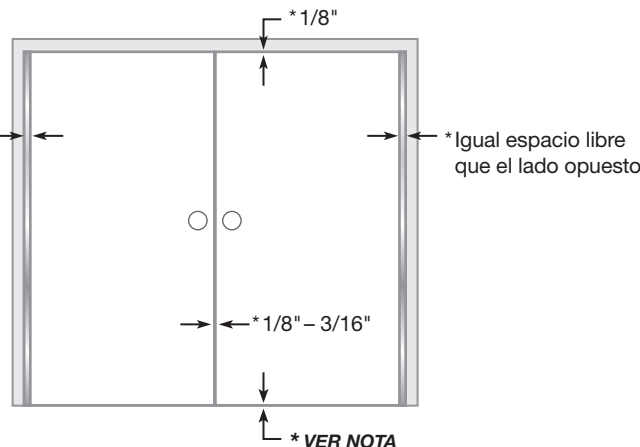
Borde cuadrado *5/16"
Borde biselado *11/32"



Puertas dobles (par)

Espacio libre en lado de bisagra

Borde cuadrado *5/16"
Borde biselado *11/32"



Herramientas necesarias

- Sierra para cortar metal
- Cinta para medir
- Broca N° 13 o de 3/16"
- Broca de 5/32" (marcos/puertas de madera)
- Destornillador Phillips N° 3
- Cuñas

Piezas suministradas

- 24 tornillos roscadores autorroscantes (SDTF) de cabeza plana Phillips sesgada N° 12 de acero inoxidable 410

Piezas opcionales

- Tornillos de cabeza plana sesgada para madera Phillips N° 12 de acero inoxidable 410
- 24 tornillos roscadores (TF) de cabeza plana Phillips sesgada N° 12 de acero inoxidable 410
- Se recomienda el uso de guantes protectores
- Se recomienda el uso de guantes protectores

Cómo cortar la charnela para que quepa

- Mantenga la charnela en la posición de "puerta cerrada" (Fig. 1).
- Determine si ésta será una instalación para diestros o zurdos.

IMPORTANTE: Corte solamente un extremo de la charnela.

El extremo cortado se instalará en la parte inferior. Guarde el patrón de templado original de seis orificios en el extremo superior de la charnela.

NOTA: SL11, SL27 y SL38 son para diestros o zurdos y permanecen para diestros o zurdos después de cortarse.

- Usando una sierra para cortar metal, comience a cortar primero a través de la tapa del engranaje.

NOTA: NO corte por el rodamiento del tornillo de ajuste.

- Vuelva a colocar cualquier rodamiento del tornillo de ajuste que hubiera podido cortarse.

A. Preparación del marco

- Use cuñas para ubicar la charnela a 1/8" debajo del travesaño para permitir tolerancia para la puerta.
- Sostenga la charnela en la posición de "puerta abierta" (Fig. 2) asegurando que el reborde de alineación de la hoja del marco esté ajustado contra la cara del marco.
- Marque (o punce) las ubicaciones de los orificios.

NOTA: Los tornillos roscadores (TF) para madera necesitan orificios piloto en las ubicaciones marcadas. Los tornillos roscadores autorroscantes (SDTF) no necesitan orificios piloto.

- Si va a usar tornillos roscadores autorroscantes (SDTF), vaya al paso 2.
- Si va a usar tornillos roscadores (TF) o para madera, taladre orificios en los lugares marcados. NO fije aún la charnela al marco.

- Marco de metal: Use una broca N° 13 (0,185") ó de 3/16" (0,188")

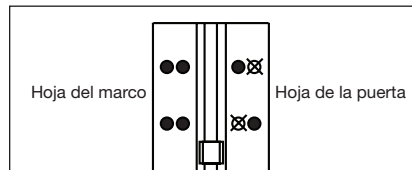
- Marco de madera: Use una broca de 5/32" (0,156")

B. Fije la puerta a la charnela

- Alinee el reborde de alineación de la hoja de la puerta o el labio de la hoja de la puerta a lo largo de la longitud total del borde de la puerta (aun si la puerta está ligeramente combada).

IMPORTANTE: El extremo superior de la charnela debe estar alineado con la parte superior de la puerta.

IMPORTANTE: Si va a instalar la charnela sobre una puerta de madera clasificada como resistente al fuego por 90 minutos, marque o punce un solo orificio en cada par de orificios que esté en la parte superior e inferior de la hoja de la puerta. NO instale los tornillos restantes en los patrones de seis orificios en la hoja de la puerta. Vea la ilustración abajo.



- Marque (o punce) los orificios. Si va a usar tornillos roscadores autorroscantes SDTF, vaya al paso 7. Si va a usar tornillos roscadores (TF) o para madera, taladre orificios en los lugares marcados.

- Puerta de metal: Use una broca N° 13 (0,185") o de 3/16" (0,188")
- Puerta de madera: Use una broca de 5/32" (0,156")

- Sujete la hoja de la puerta a la puerta usando un destornillador Phillips N° 3 y los sujetadores provistos.

C. Sujete la puerta al marco

- Coloque la puerta a 90 grados respecto al marco. Coloque una cuña en la puerta a la altura apropiada de manera que la puerta se alinee con los orificios superiores de los tornillos.
- Instale dos tornillos en la parte superior de la charnela. Quite la cuña y alinee los orificios restantes. Introduzca los tornillos en los orificios del medio y los dos de la parte inferior.
- Verifique que la puerta gire y tenga la tolerancia adecuada antes de instalar los tornillos restantes.

Refuerzo y remaches Rivnuts®

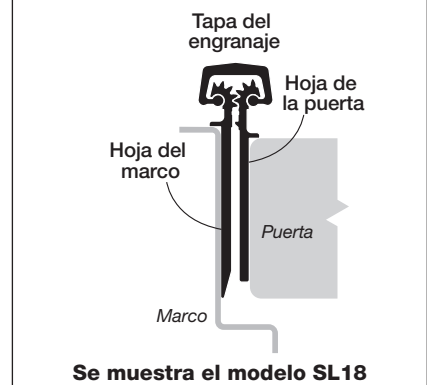
No es necesario reforzar la bisagra excepto en puertas de uso extremadamente frecuente, extremadamente altas, extremadamente pesadas o extra anchas. Se recomienda el uso de Rivnuts en el marco y la puerta cuando la puerta exceda las 450 lb (204 kg).

NOTA: Solamente deben usarse remaches Rivnuts® de acero SELECT con charnelas SELECT, clasificadas como resistentes al fuego.

Marcos empotrados en cemento

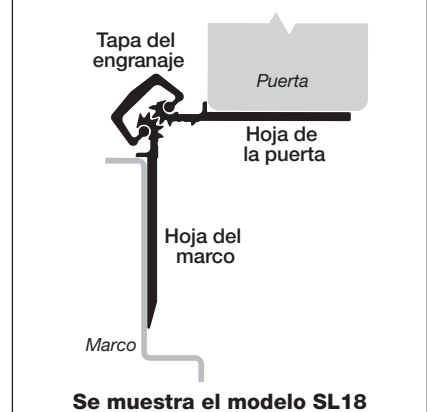
Para facilitar la instalación, se recomienda instalar algún tipo de salpicadera detrás del marco. No use tornillos roscadores autorroscantes (SDTF) para taladrar en los

Fig. 1 Posición de puerta cerrada



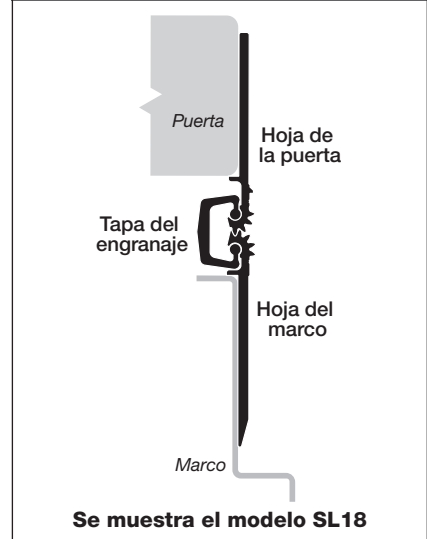
Se muestra el modelo SL18

Fig. 2 Puerta abierta a 90°



Se muestra el modelo SL18

Fig. 3 Puerta abierta a 180°



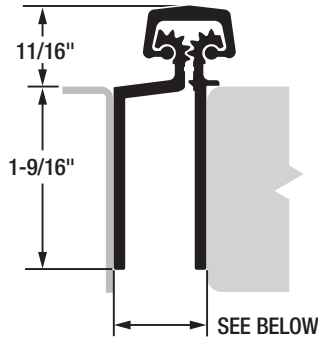
Se muestra el modelo SL18

marcos de cemento. Si no se han usado salpicaderas, taladre cuidadosamente orificios que sirvan como guía a través del marco y quite el cemento para poder colocar el tornillo. No agrande los orificios del marco.

Charnelas clasificadas como resistentes al fuego



Todas las bisagras SELECT (excepto SL71, SL77 y bisagras para particiones de inodoros) tienen una clasificación UL de 90 minutos, sin pasadores o espárragos contra incendios. Por favor contacte a SELECT para obtener información completa acerca de las charnelas clasificadas como resistentes al fuego.



Door Clearances

For Square and Beveled-Edge Doors

IMPORTANT: All uncut SL71 hinges are non-handed and templated. They become handed after cutting.

* **NOTE:** Recommended spacing, although no NFPA 80 requirements.

Important Warranty Information:

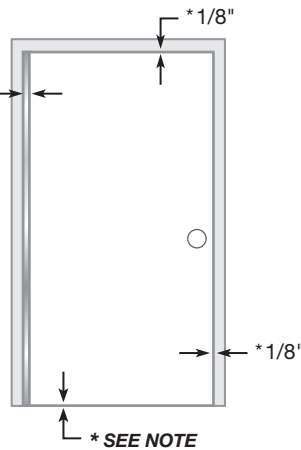
The following actions will void any warranty, expressed or implied:

- Failure to install the hinge according to manufacturer's specifications and requirements. (For more information, visit selecthingerequirements.com.)
- Use of fasteners other than those supplied with the hinge.
- Unauthorized field modifications, including alteration or removal of the factory-applied lubricant, altering the original finish or painting the hinge.

Single Door

Hinge side clearance

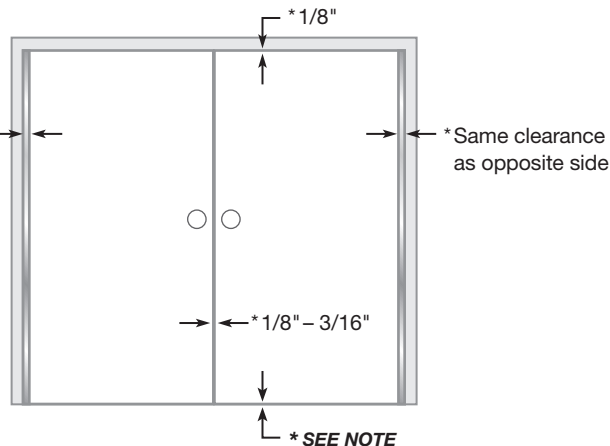
Square Edge	* 13/16"
Beveled Edge	* 27/32"



Double Doors (Pair)

Hinge side clearance

Square Edge	* 13/16"
Beveled Edge	* 27/32"



Tools Needed

- Metal-cutting saw
- Tape measure
- #13 or 3/16" drill bit
- 5/32" drill bit (wood frames/doors)
- #3 Phillips drive
- Shims

Parts Supplied

- #12-24 thread-forming (TF) 410 SS Phillips undercut flathead screws

Optional Parts

- #12 410 SS Phillips undercut flathead wood screws
- #12-24 self-drilling, thread-forming (SDTF) 410 SS Phillips undercut flathead screws
- Protective gloves are recommended

How to Cut the Hinge to Fit

- A. Keep hinge in "door closed" position (Fig. 1).
- B. Determine whether this will be a right-hand or left-hand installation.

IMPORTANT: Cut only one end of hinge. Cut end will be installed at the bottom. Keep original templated six-hole pattern at top end of hinge.

- C. Using a metal-cutting saw, begin the cut through the gear cap first.

NOTE: DO NOT cut through a set screw bearing.

- D. Reinstall any set screw bearing that may have been cut off.

A. Prepare Frame

1. Shim hinge to 1/8" below the header to allow for door clearance.
2. Hold hinge in "door open" position (Fig. 2), making sure frame leaf alignment is tight against frame face.
3. Mark (or centerpunch) hole locations.

NOTE: TF screws and wood screws require pilot holes at marked locations. SDTF screws do not require pilot holes.

4. If using SDTF screws, go to Step 5. If using TF or wood screws, drill holes at marked locations. DO NOT attach hinge to the frame at this time.
 - Metal frame: Use #13 (.185") bit or 3/16" (.188") bit
 - Wood frame: Use 5/32" (.156") bit

B. Attach Door to Hinge

5. Align the door leaf alignment flange along the full length of the door edge (even if the door is slightly warped).

IMPORTANT: Top end of the hinge must be flush with the top of the door.

6. Mark (or centerpunch) holes. If using SDTF screws, go to Step 7. If using TF or wood screws, drill holes at marked locations.
 - Metal door: Use #13 (.185") bit or 3/16" (.188") bit
 - Wood door: Use 5/32" (.156") bit
7. Fasten door leaf to door using #3 Phillips drive and fasteners provided.

C. Attach Door to Frame

8. Position door at 90 degrees to the frame. Shim door to the proper height so the door aligns with the top screw holes.
9. Install two screws at the top of hinge. Remove shim and align remaining holes. Install screws in middle and bottom two holes.
10. Check door for proper swing and clearance before installing remaining screws.

Reinforcing & Rivnuts®

No hinge reinforcement is necessary except on extremely high-frequency, extremely tall, extremely heavy or extra-wide doors. Rivnuts are recommended for use in the frame and door when the door exceeds 450 lb.

NOTE: Only SELECT steel Rivnuts are to be used with fire-rated SELECT hinges.

Grouted/Slushed-in Frames

For ease of installation, it is recommended some sort of mudguard be installed behind the frame. Do not use self-drilling, thread-forming (SDTF) screws to drill into grouted frames. If mudguards have not been used, carefully drill pilot holes through frame and remove grout for screw clearance. Do not oversize holes in frame.

Fig. 1 Door Closed Position

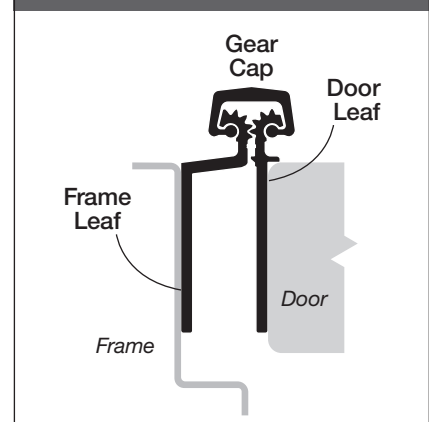


Fig. 2 Door Open 90°

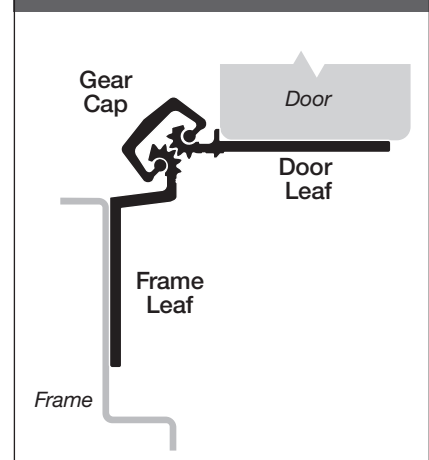
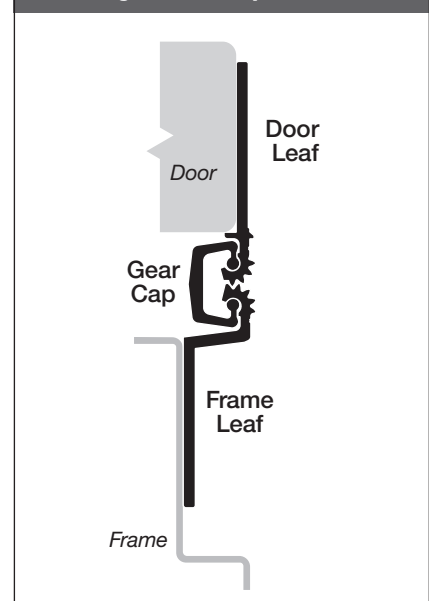
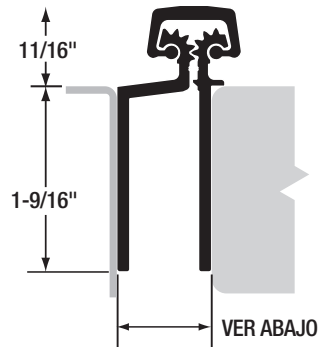


Fig. 3 Door Open 180°





Espacios libres de puerta

Para puertas de borde cuadrado y de borde biselado

IMPORTANTE: Todas las bisagras SL71 sin cortar son invertibles y con plantilla y se vuelven no invertibles después del corte.

* **NOTA:** Espaciado recomendado, aunque no es un requisito de NFPA 80.

Información importante sobre la garantía:

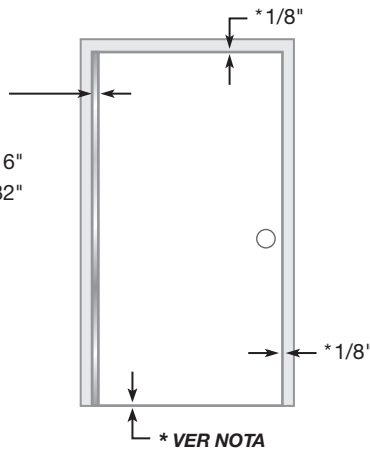
Las acciones siguientes invalidarán cualquier garantía, ya sea explícita o implícita:

- No instalar la bisagra siguiendo las especificaciones y requisitos del fabricante. (Visite selecthingerequirements.com para obtener más información)
- Usar sujetadores que no sean los que se suministran con la bisagra.
- Modificaciones de terreno no autorizadas, como alterar o retirar el lubricante aplicado en la fábrica, alterar el acabado original o pintar la bisagra.

Puerta simple

Espacio libre en lado de bisagra

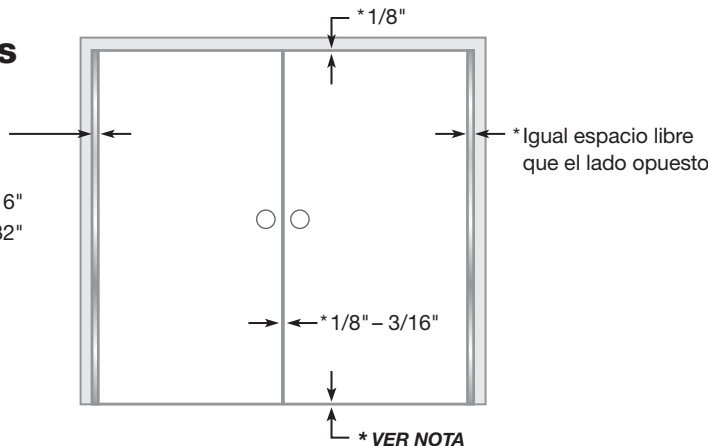
Borde cuadrado * 13/16"
 Borde biselado * 27/32"



Puertas dobles (par)

Espacio libre en lado de bisagra

Borde cuadrado * 13/16"
 Borde biselado * 27/32"



Herramientas necesarias

- Sierra para cortar metal
- Cinta para medir
- Broca Nro. 13 o de 3/16" (4,8 mm)
- Broca de 5/32" (4 mm) (marcos/ puertas de madera)
- Destornillador Phillips Nro. 3
- Cuñas

Piezas suministradas

- Tornillos Phillips de acero inoxidable 410 roscadores (TF) Nro. 12-24 de cabeza plana sesgada

Piezas opcionales

- Tornillos Phillips de acero inoxidable 410 Nro. 12 de cabeza plana sesgada, para madera
- Tornillos Phillips de acero inoxidable 410 roscadores autorroscantes (SDTF) Nro. 12-24 de cabeza plana sesgada
- Se recomienda el uso de guantes protectores

Cómo cortar la charnela para que encaje

- A. Mantenga la charnela en la posición de "puerta cerrada" (Fig. 1).
- B. Determine si esta será una instalación para diestros o zurdos.

IMPORTANTE: Corte solamente un extremo de la charnela. El extremo cortado se instalará en la parte inferior. Guarde el patrón de plantilla original de seis orificios en el extremo superior de la charnela.

- C. Con una sierra para cortar metal, comience a cortar primero a través de la tapa de los engranajes.

NOTA: NO corte por el rodamiento del tornillo opresor.

- D. Vuelva a colocar cualquier rodamiento del tornillo opresor que hubiera podido cortarse.

A. Preparación del marco

1. Coloque cuñas en la charnela a 1/8" (3,2 mm) debajo del travesaño para dejar tolerancia para la puerta.
2. Sostenga la charnela en la posición de "puerta abierta" (Fig. 2) y asegúrese de que la alineación de la hoja del marco esté ajustada contra la cara del marco.
3. Marque (o punce) las ubicaciones de los orificios.

NOTA: Los tornillos roscadores (TF) y los de madera necesitan orificios piloto en las ubicaciones marcadas. Los tornillos roscadores autorroscantes (SDTF) no necesitan orificios piloto.

4. Si va a usar tornillos roscadores autorroscantes (SDTF), vaya al paso 5. Si va a usar tornillos roscadores (TF) o para madera, taladre orificios en los lugares marcados. NO fije aún la charnela al marco en este momento.

- Marco de metal: Use una broca Nro. 13 (0,185" [4,7 mm]) o de 3/16" (0,188" [4,8 mm])
- Marco de madera: Use una broca de 5/32" (0,156" [4 mm])

B. Fije la puerta a la charnela

5. Alinee el reborde de alineación de la hoja de la puerta a lo largo de la longitud total del borde de la puerta (aun si la puerta está ligeramente combada).

IMPORTANTE: El extremo superior de la charnela debe estar alineado con la parte superior de la puerta.

6. Marque (o punce) los orificios. Si va a usar tornillos roscadores autorroscantes (SDTF), vaya al paso 7. Si va a usar tornillos roscadores (TF) o para madera, taladre orificios en los lugares marcados.

- Marco de metal: Use una broca Nro. 13 (0,185" [4,7 mm]) o de 3/16" (0,188" [4,8 mm])
- Marco de madera: Use una broca de 5/32" (0,156" [4 mm])

7. Sujete la hoja de la puerta a la puerta usando el destornillador Phillips Nro. 3 y los sujetadores provistos.

C. Sujete la puerta al marco

8. Coloque la puerta a 90 grados respecto del marco. Coloque una cuña en la puerta a la altura apropiada de manera que la puerta se alinee con los orificios superiores de los tornillos.
9. Instale dos tornillos en la parte superior de la charnela. Retire la cuña y alinee los orificios restantes. Instale los tornillos en los dos orificios del medio y de la parte inferior.
10. Verificar que la puerta tenga la abertura y tolerancia adecuadas antes de instalar los tornillos restantes.

Refuerzo y remaches Rivnuts®

No es necesario reforzar la bisagra excepto en puertas de uso extremadamente frecuente, extremadamente altas, extremadamente pesadas o extra anchas. Se recomienda el uso de remaches Rivnuts en el marco y la puerta cuando la puerta exceda las 450 lb (204 kg).

NOTA: Solamente deben usarse remaches Rivnuts de acero SELECT con charnelas SELECT, clasificadas como resistentes al fuego.

Marcos empotrados en cemento

Para facilitar la instalación, se recomienda instalar una salpicadera detrás del marco. No use tornillos roscadores autorroscantes (SDTF) para taladrar en los marcos empotrados. Si no se han usado salpicaderas, taladre cuidadosamente orificios piloto a través del marco y quite el cemento a fin de hacer espacio para el tornillo. No haga los orificios demasiado grandes en el marco.

Fig. 1 Posición de puerta cerrada

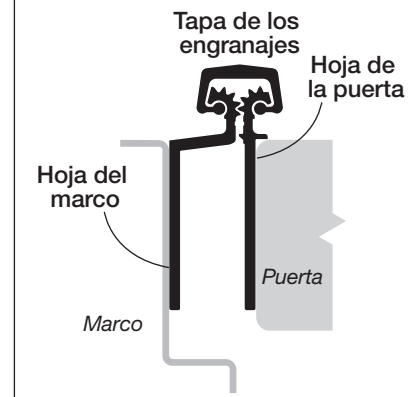


Fig. 2 Puerta abierta a 90°

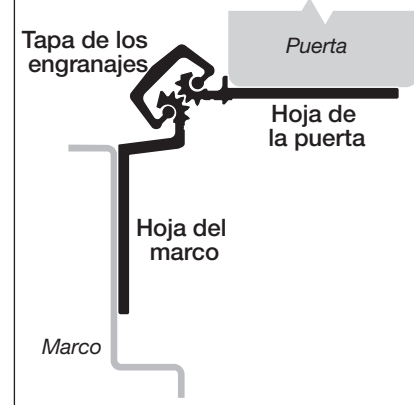
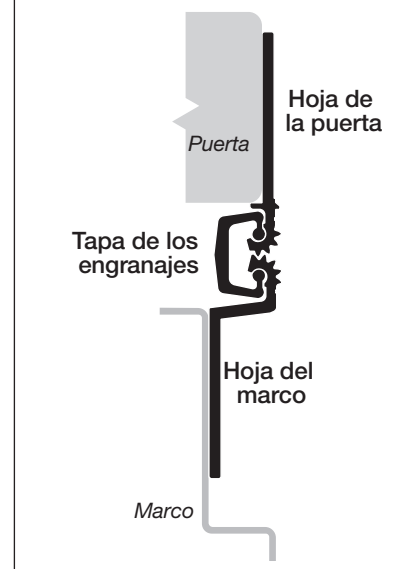


Fig. 3 Puerta abierta a 180°



Concealed Geared Hinges

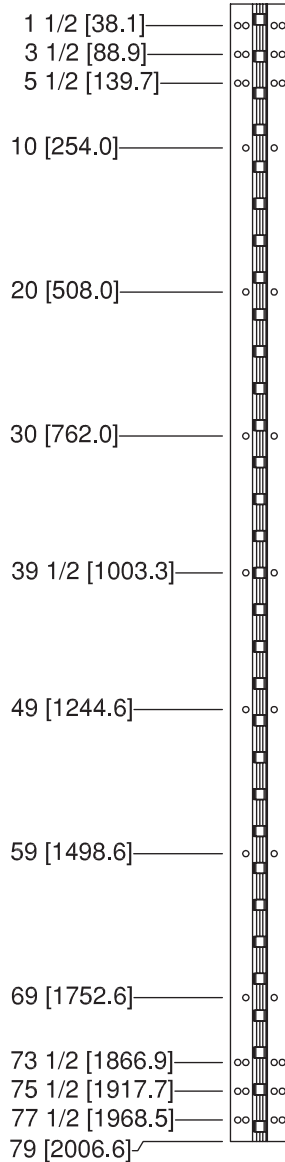
- All dimensions are measured in inches and [millimeters] from the top of the door to the centerline of the holes and bearings.
- Choose location(s) for CTW prep(s) from bearing slot(s) dimensioned. CTW4/5 = 1 location; CTW8/10 = 2 locations; CTW12 = 3 locations.

For 79" HD600 Models SL11, SL24 CLEAR ONLY

For CTW prep locations on a 79" hinge, please go to the 83" template. SELECT will use an 83" hinge and cut to 79" when a CTW is required on a 79" hinge.

38 fasteners / 31 bearings

HOLES

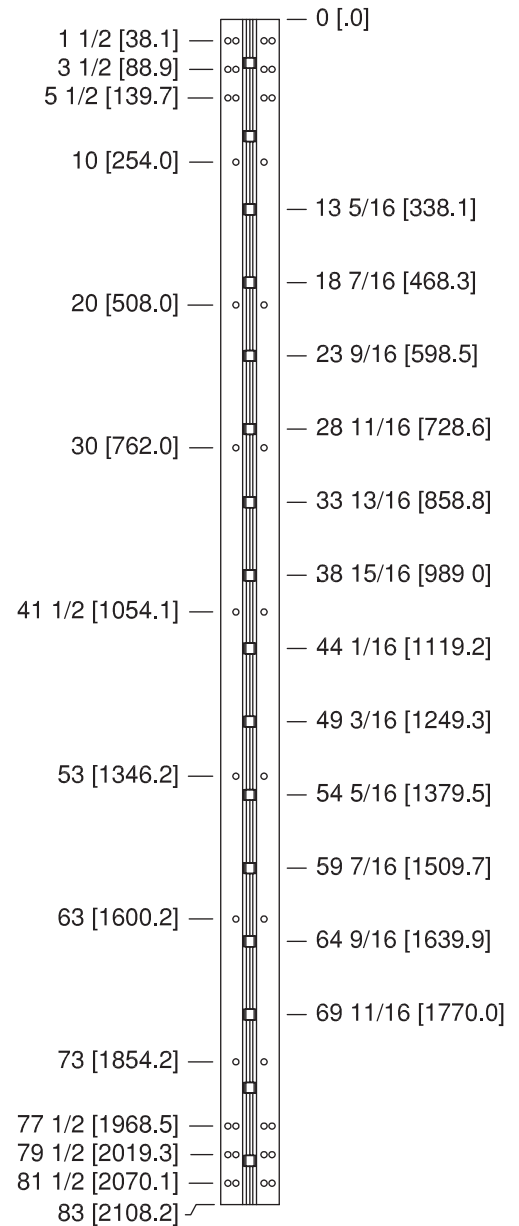


For 83" HD300 Models SL11, SL14, SL18, SL24

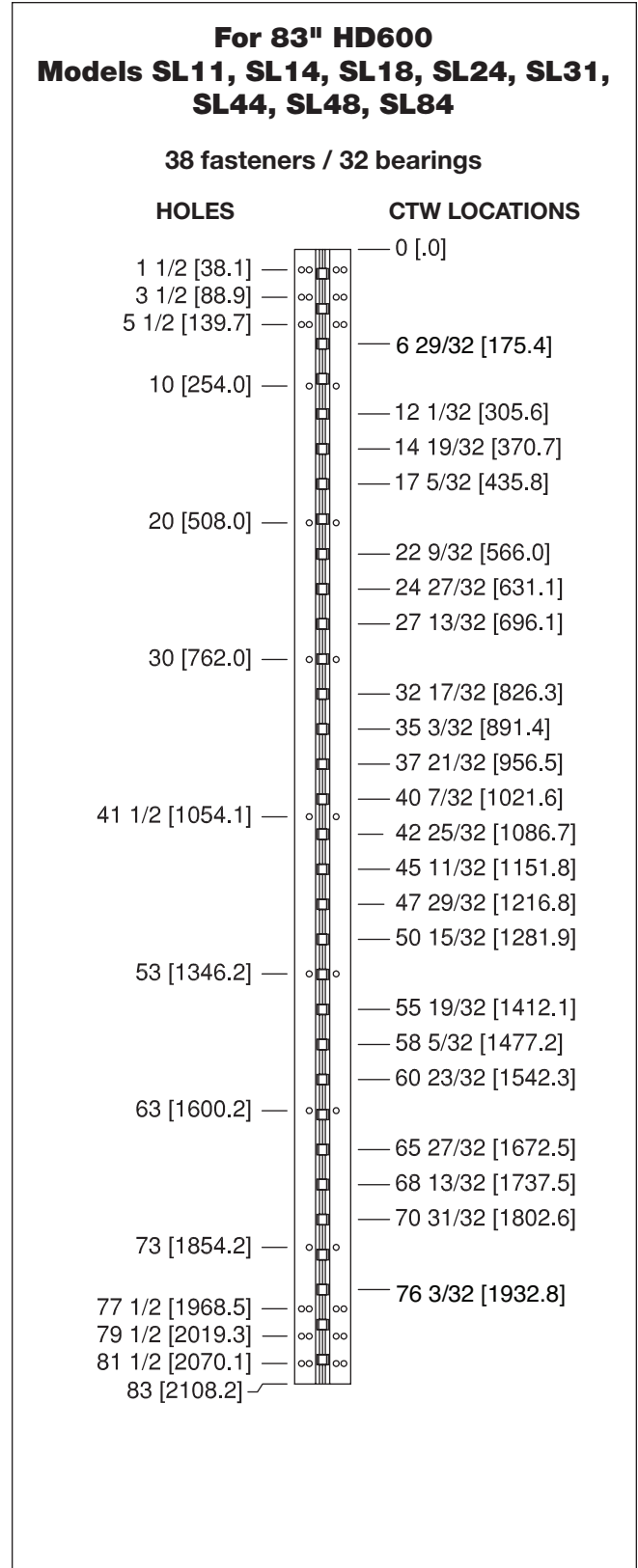
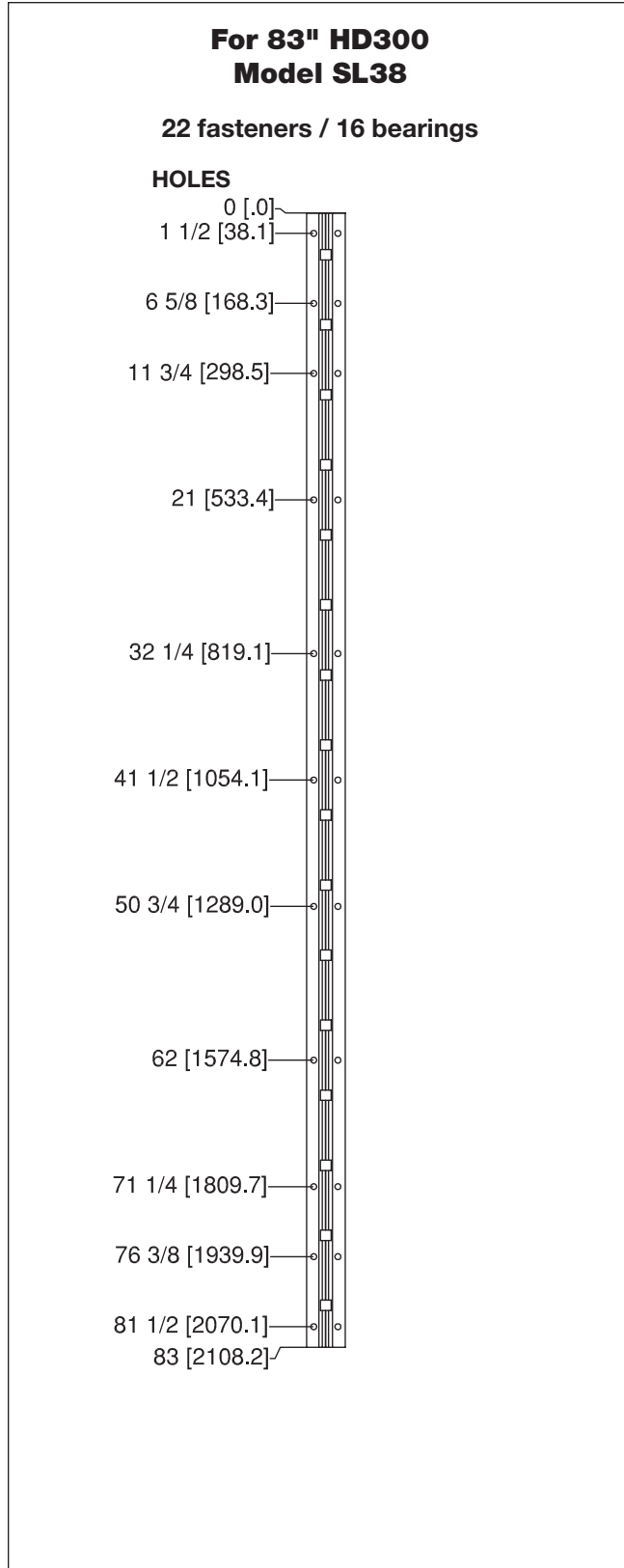
38 fasteners / 16 bearings

HOLES

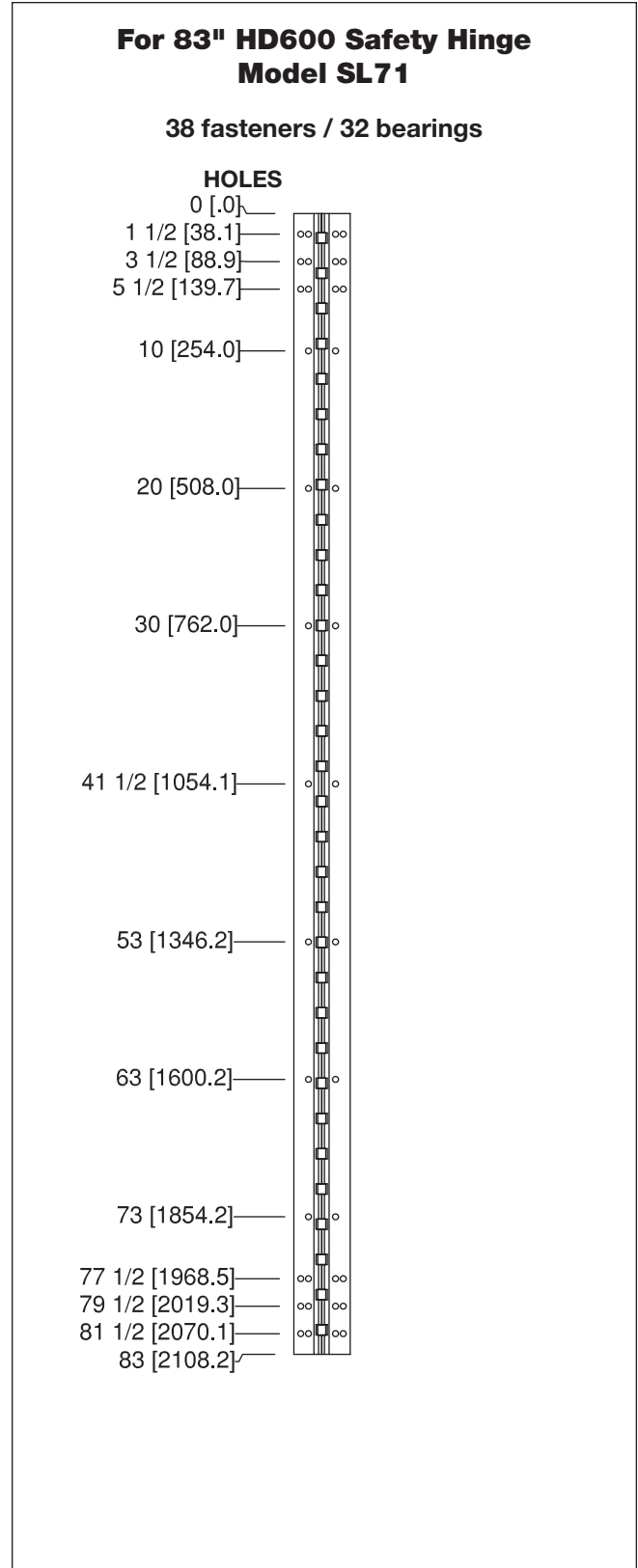
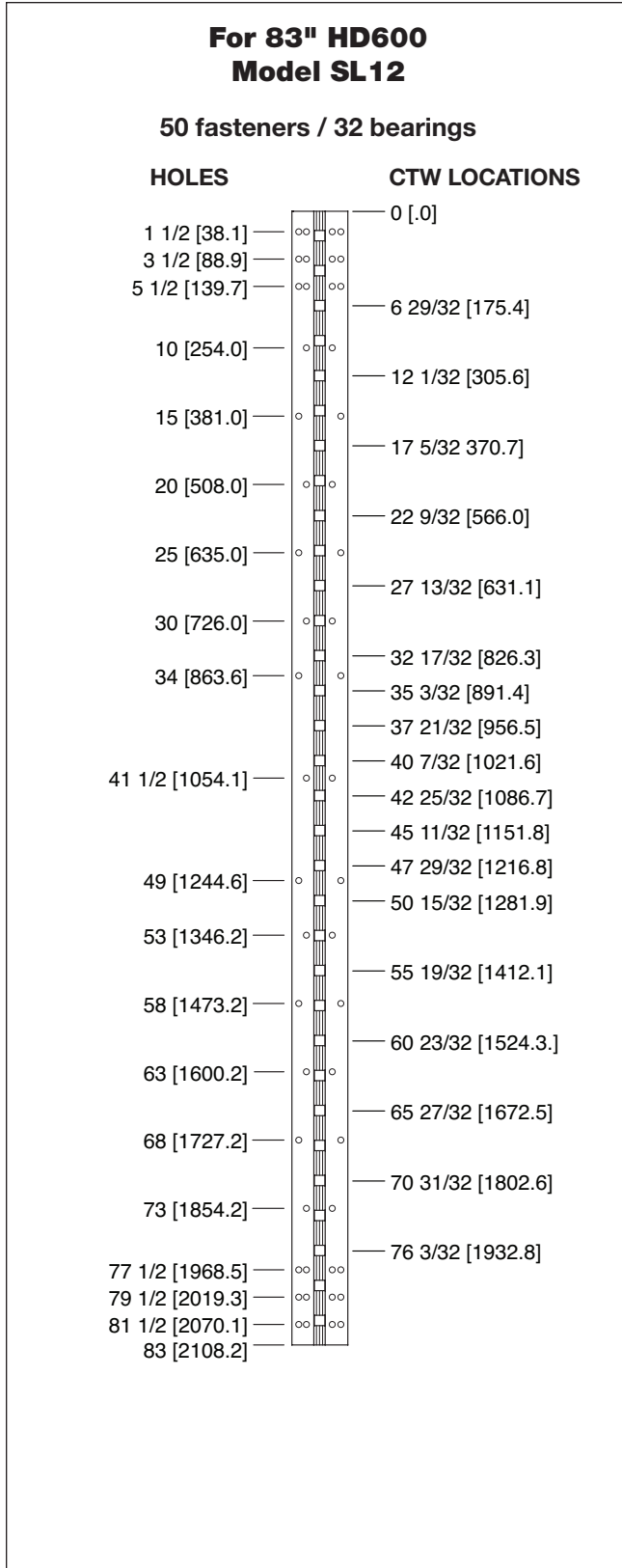
CTW LOCATIONS



- All dimensions are measured in inches and [millimeters] from the top of the door to the centerline of the holes and bearings.
- Choose location(s) for CTW prep(s) from bearing slot(s) dimensioned. CTW4/5 = 1 location; CTW8/10 = 2 locations; CTW12 = 3 locations.



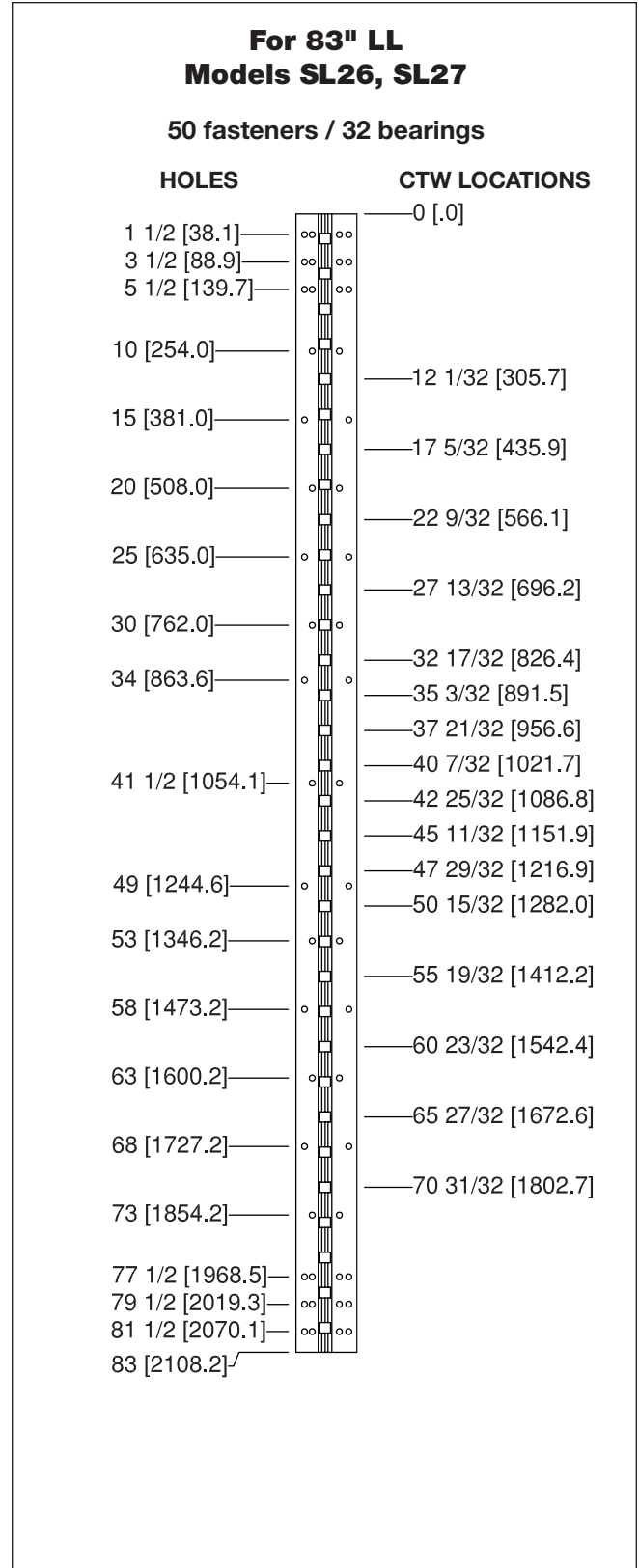
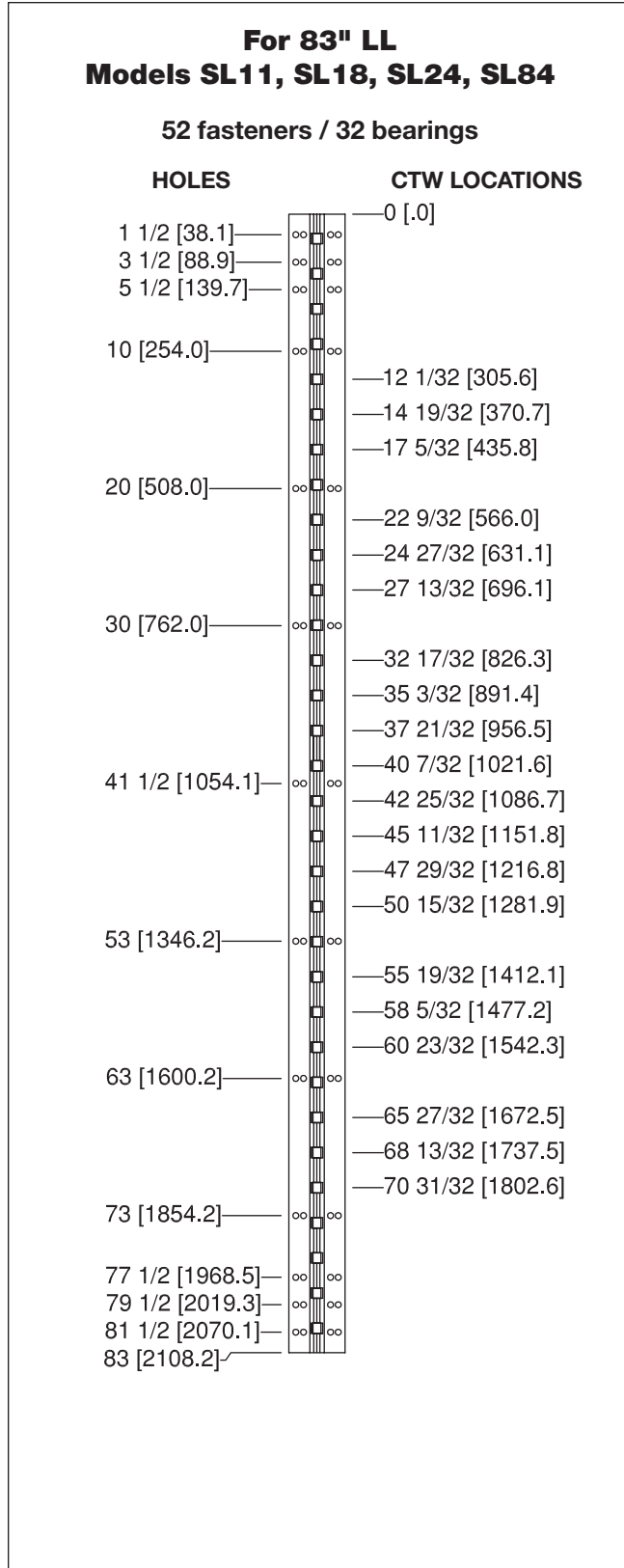
- All dimensions are measured in inches and [millimeters] from the top of the door to the centerline of the holes and bearings.
- Choose location(s) for CTW prep(s) from bearing slot(s) dimensioned. CTW4/5 = 1 location; CTW8/10 = 2 locations; CTW12 = 3 locations.



Concealed Geared Hinges

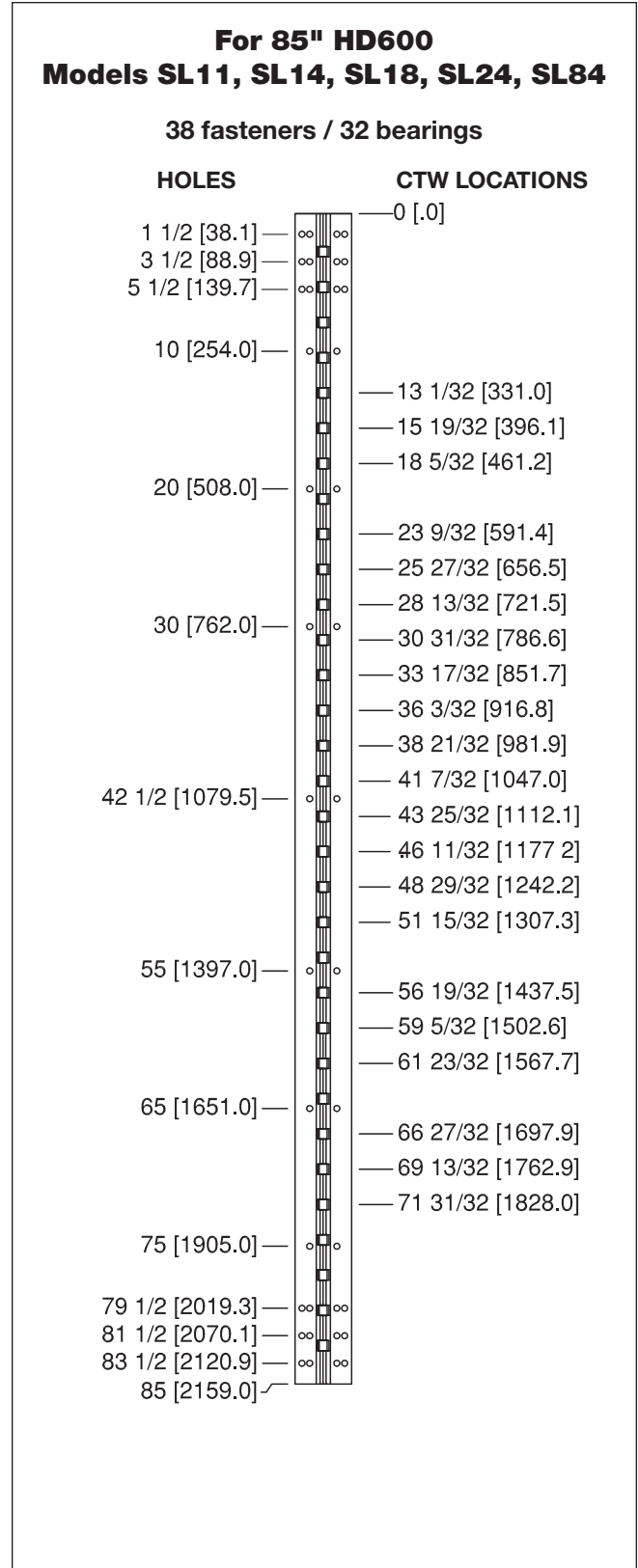
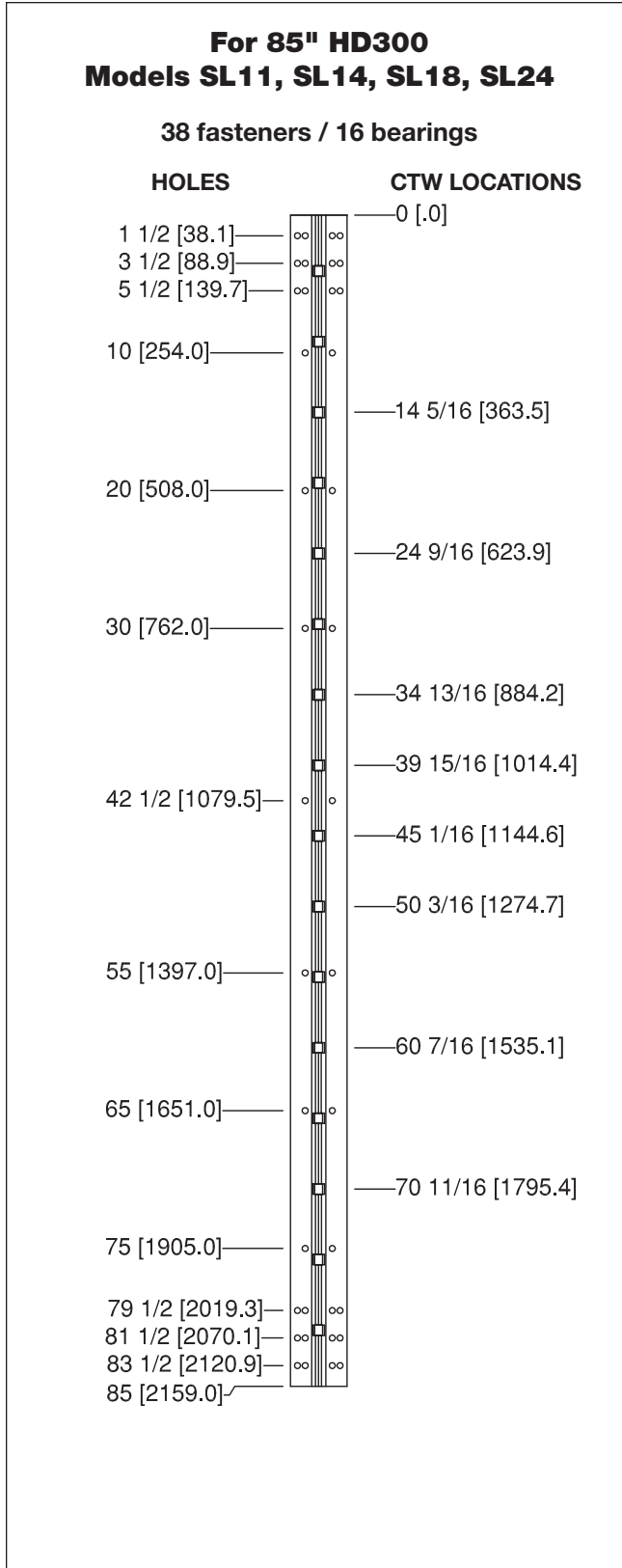


- All dimensions are measured in inches and [millimeters] from the top of the door to the centerline of the holes and bearings.
- Choose location(s) for CTW prep(s) from bearing slot(s) dimensioned. CTW4/5 = 1 location; CTW8/10 = 2 locations; CTW12 = 3 locations.

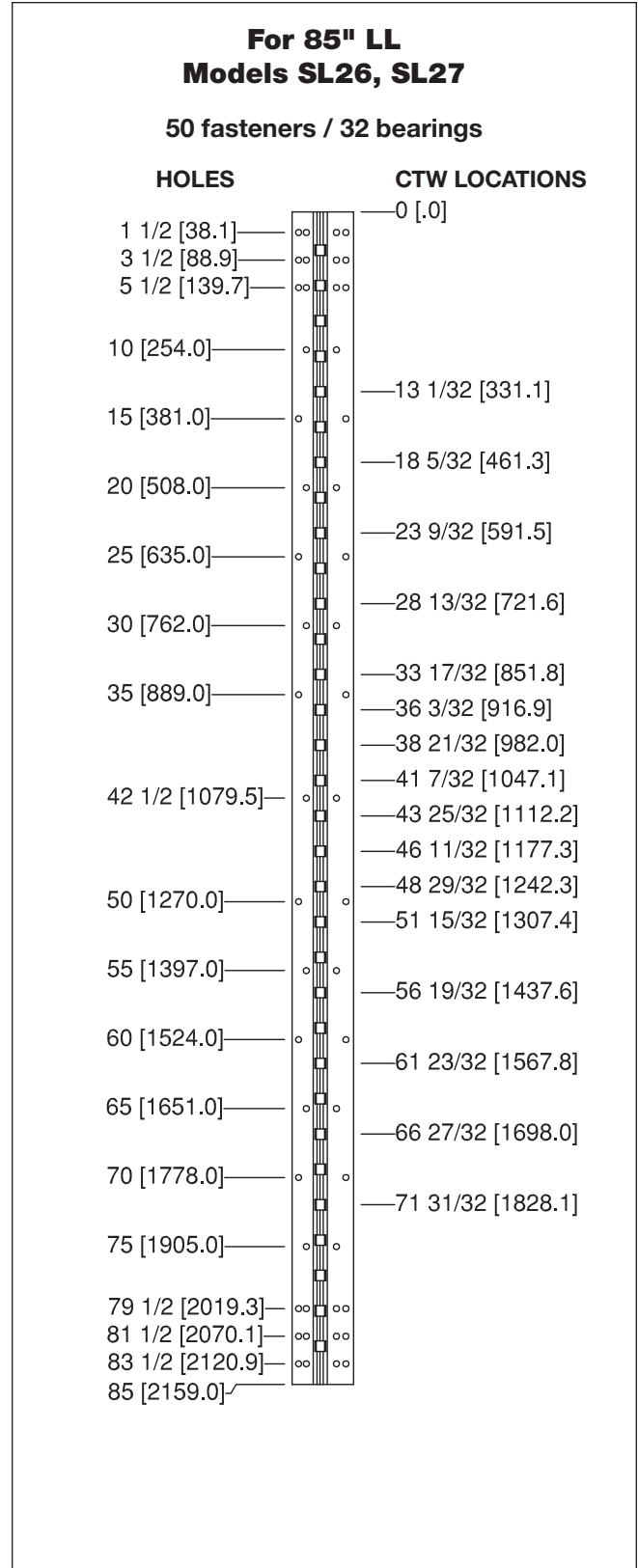
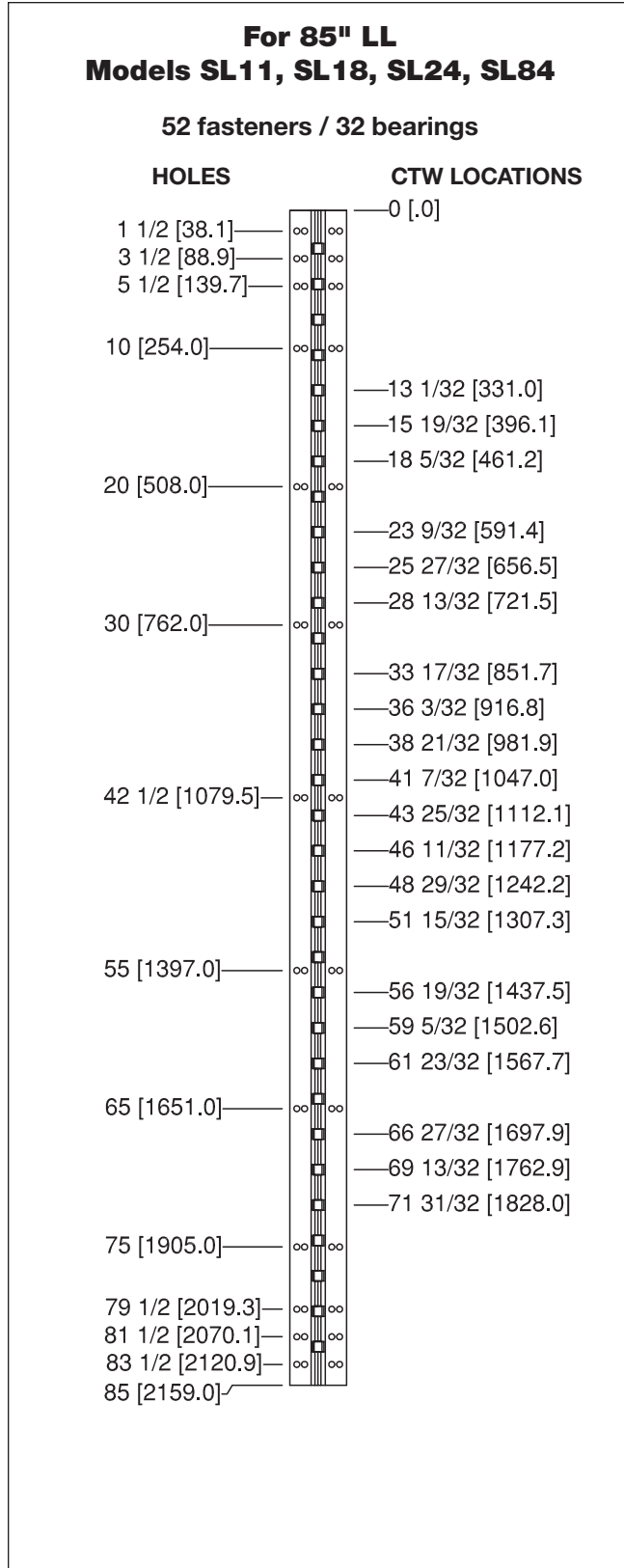


Concealed Geared Hinges

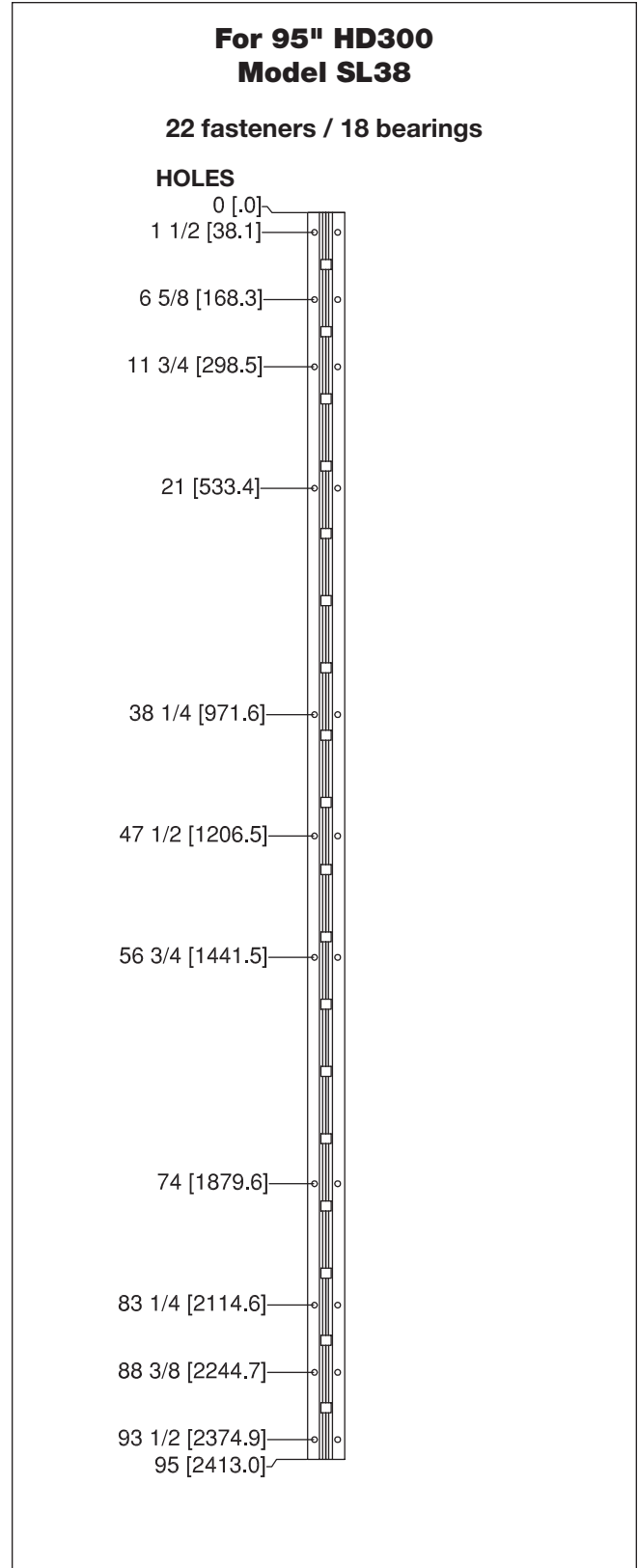
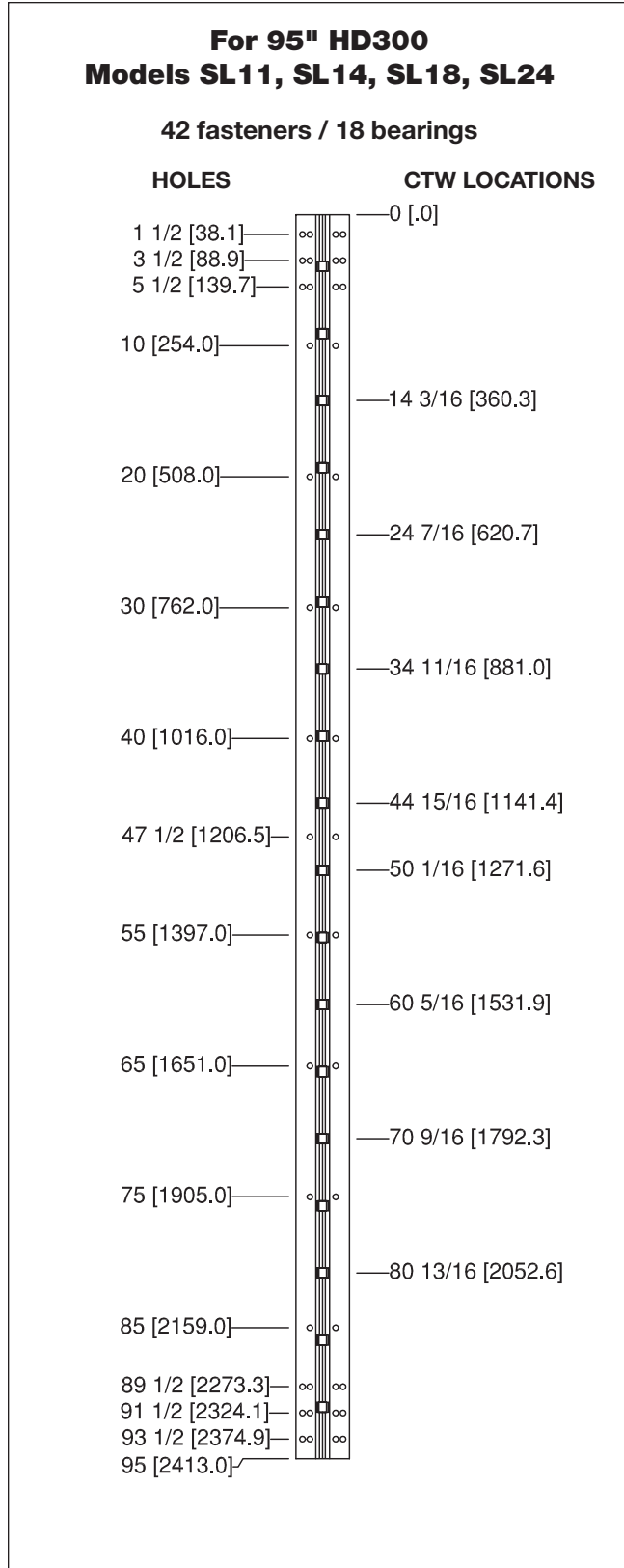
- All dimensions are measured in inches and [millimeters] from the top of the door to the centerline of the holes and bearings.
- Choose location(s) for CTW prep(s) from bearing slot(s) dimensioned. CTW4/5 = 1 location; CTW8/10 = 2 locations; CTW12 = 3 locations.



- All dimensions are measured in inches and [millimeters] from the top of the door to the centerline of the holes and bearings.
- Choose location(s) for CTW prep(s) from bearing slot(s) dimensioned. CTW4/5 = 1 location; CTW8/10 = 2 locations; CTW12 = 3 locations.



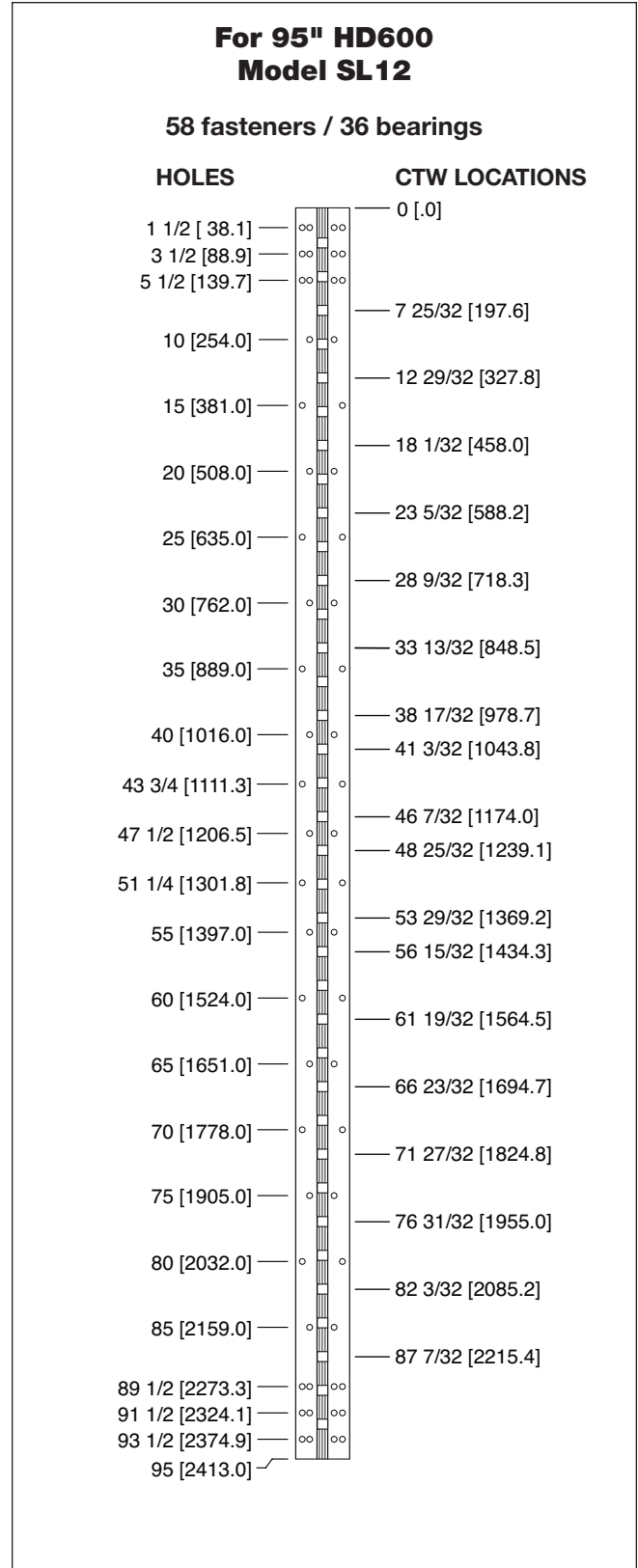
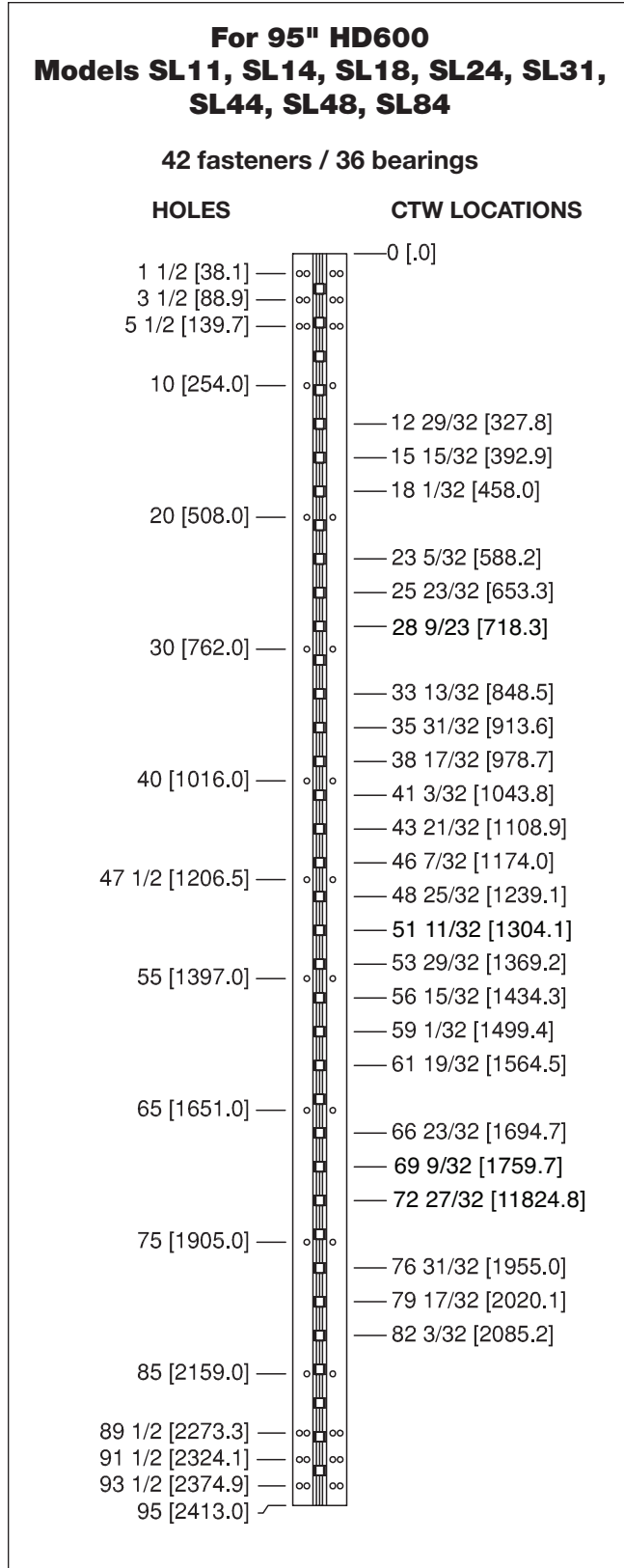
- All dimensions are measured in inches and [millimeters] from the top of the door to the centerline of the holes and bearings.
- Choose location(s) for CTW prep(s) from bearing slot(s) dimensioned. CTW4/5 = 1 location; CTW8/10 = 2 locations; CTW12 = 3 locations.



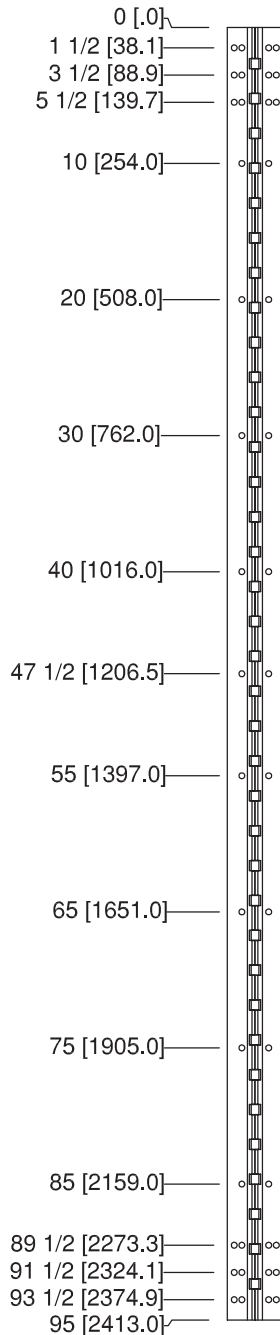
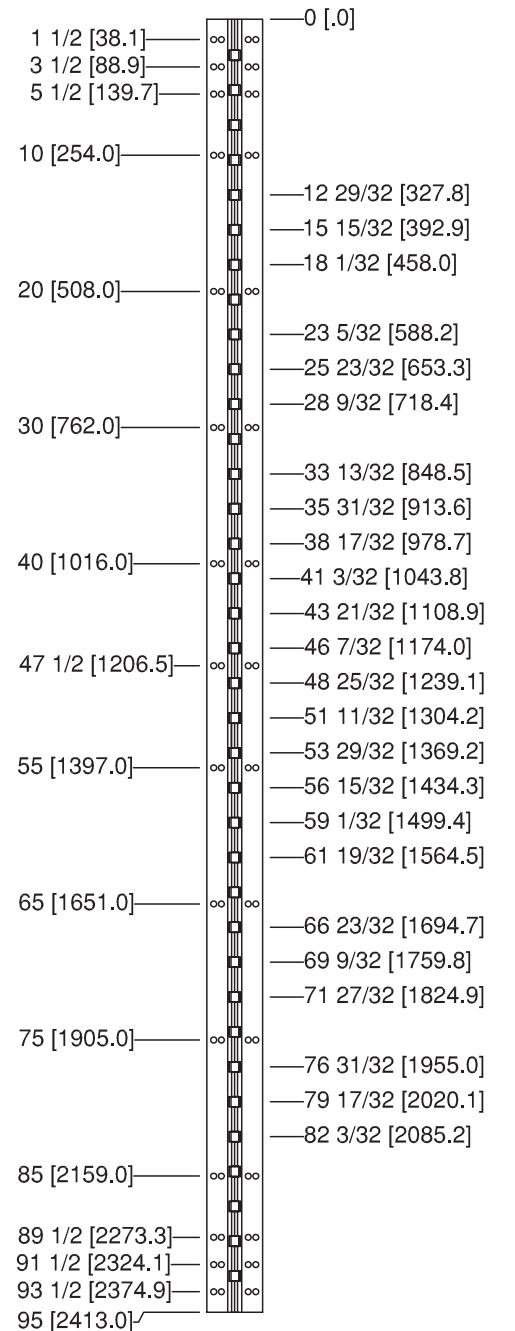
Concealed Geared Hinges



- All dimensions are measured in inches and [millimeters] from the top of the door to the centerline of the holes and bearings.
- Choose location(s) for CTW prep(s) from bearing slot(s) dimensioned. CTW4/5 = 1 location; CTW8/10 = 2 locations; CTW12 = 3 locations.



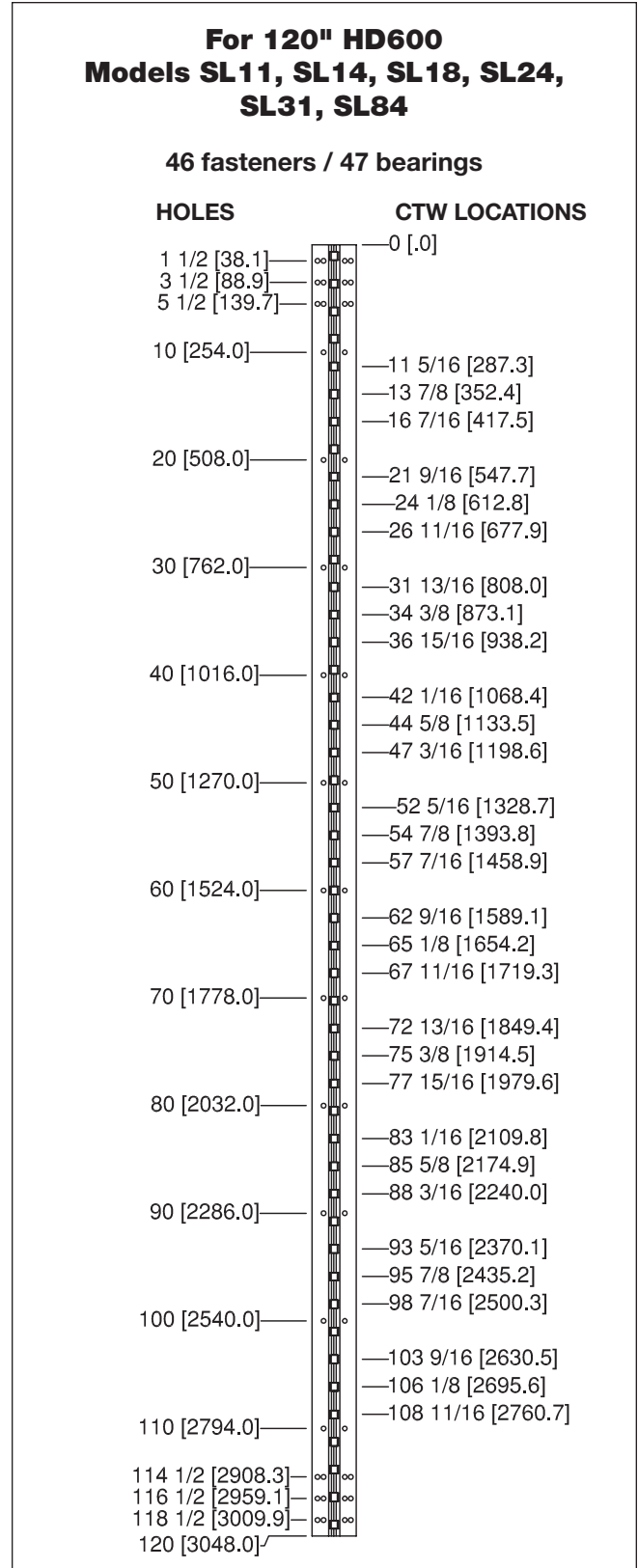
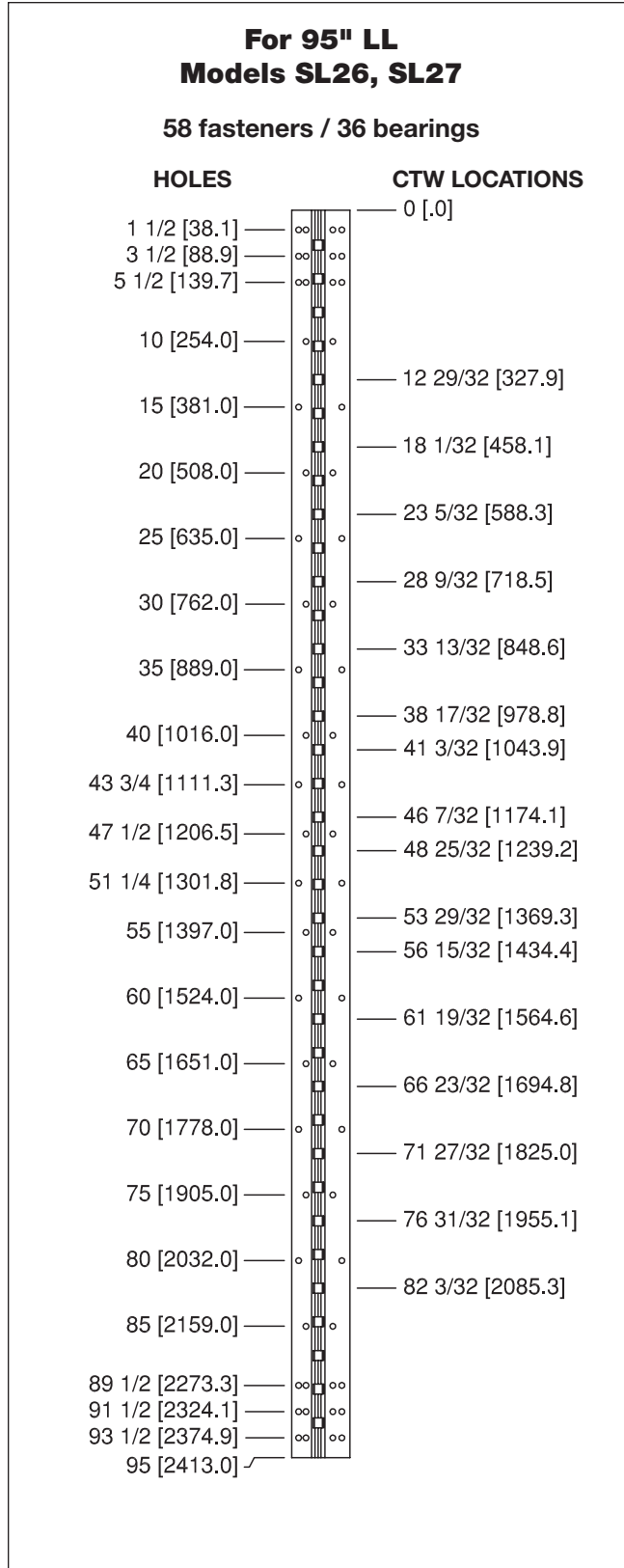
- All dimensions are measured in inches and [millimeters] from the top of the door to the centerline of the holes and bearings.
- Choose location(s) for CTW prep(s) from bearing slot(s) dimensioned. CTW4/5 = 1 location; CTW8/10 = 2 locations; CTW12 = 3 locations.

**For 95" HD600 Safety Hinge
Model SL71**
42 fasteners / 36 bearings
HOLES

**For 95" LL
Models SL11, SL18, SL24, SL84**
60 fasteners / 36 bearings
HOLES
CTW LOCATIONS


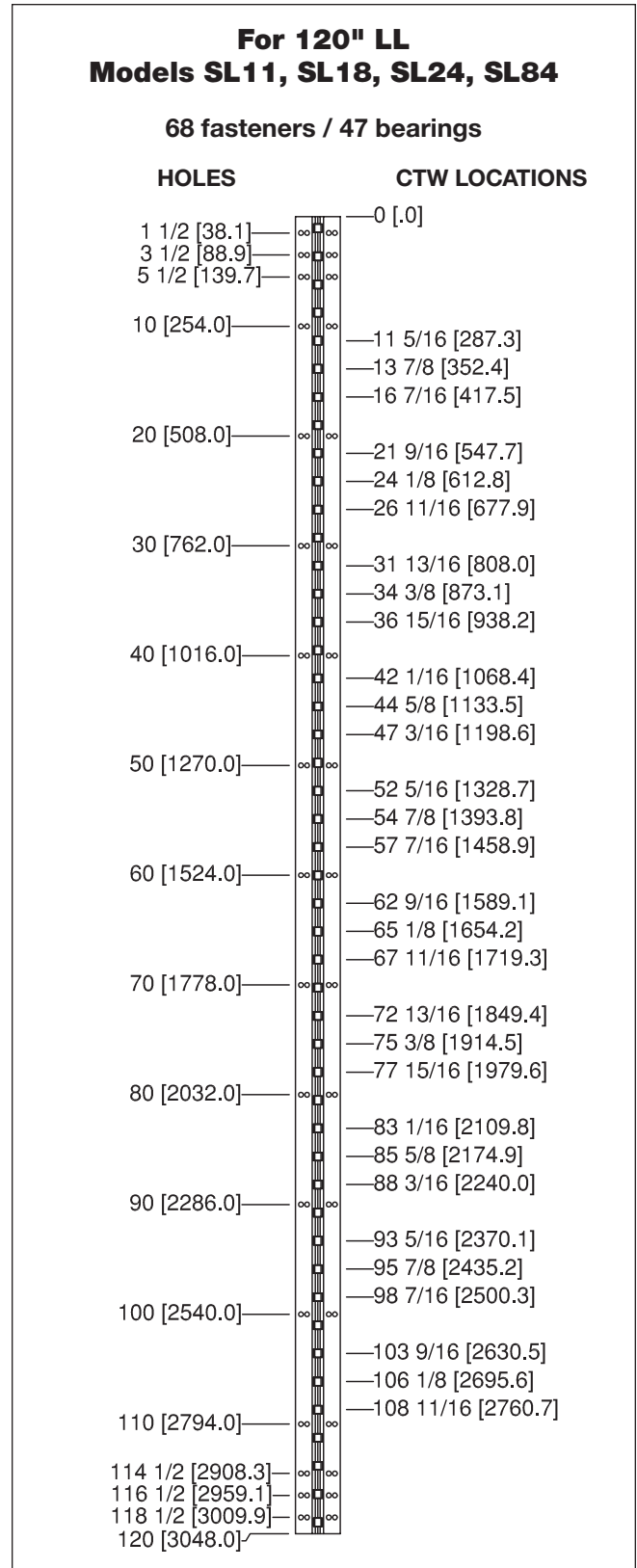
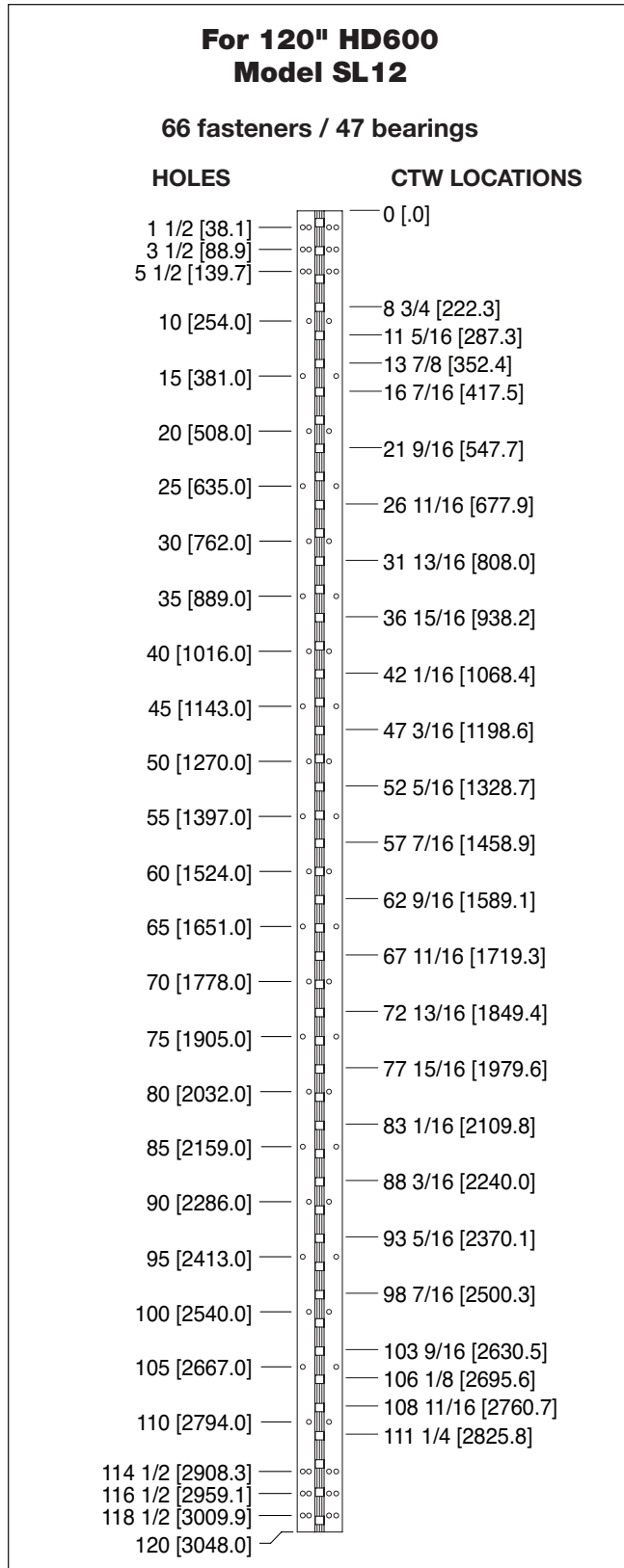
Concealed Geared Hinges



- All dimensions are measured in inches and [millimeters] from the top of the door to the centerline of the holes and bearings.
- Choose location(s) for CTW prep(s) from bearing slot(s) dimensioned. CTW4/5 = 1 location; CTW8/10 = 2 locations; CTW12 = 3 locations.



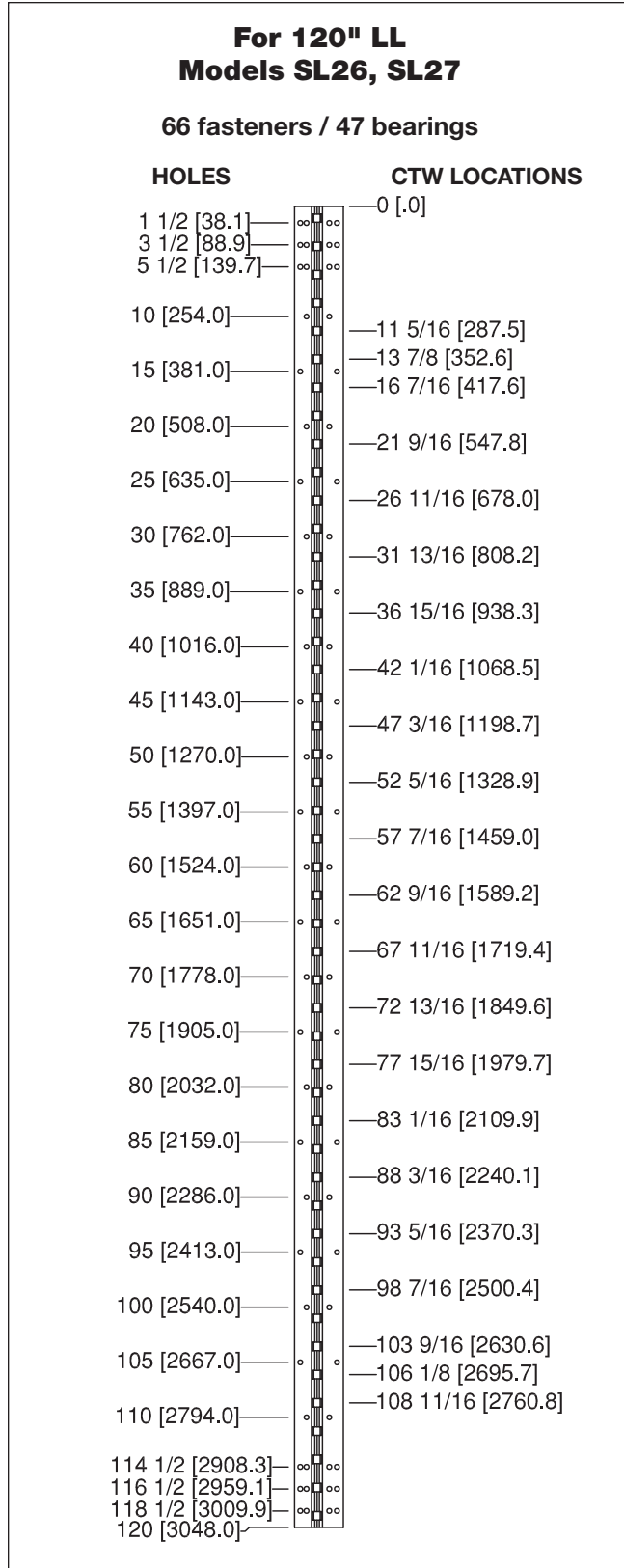
- All dimensions are measured in inches and [millimeters] from the top of the door to the centerline of the holes and bearings.
- Choose location(s) for CTW prep(s) from bearing slot(s) dimensioned. CTW4/5 = 1 location; CTW8/10 = 2 locations; CTW12 = 3 locations.



Concealed Geared Hinges



- All dimensions are measured in inches and [millimeters] from the top of the door to the centerline of the holes and bearings.
- Choose location(s) for CTW prep(s) from bearing slot(s) dimensioned. CTW4/5 = 1 location; CTW8/10 = 2 locations; CTW12 = 3 locations.



Concealed Geared Hinges

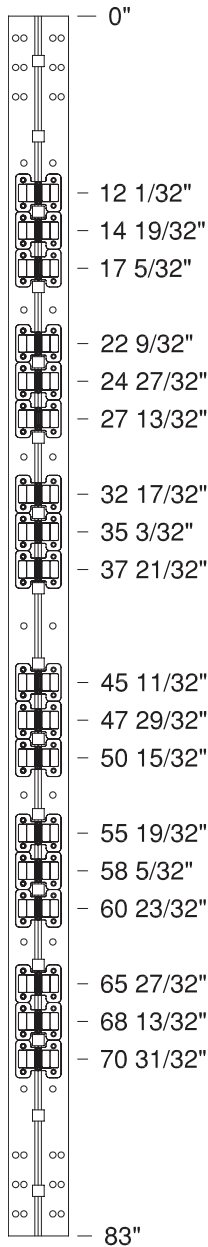


- All dimensions are measured in inches from the top of the door to the centerline of the ATW panels.
- Choose location for ATW prep. ATW4 = 1 location; ATW8 = 1 location; ATW12 = 1 location.

- Please visit www.select-hinges.com/specifications/templates for ATW location templates for SL12, SL26, and SL27 hinges.
- **NOTE:** For 90-degree openings, please specify at time of order for no upcharge. There will be an upcharge for 90-degree ATW cover plates when ordered separately and clear or bronze must be specified.

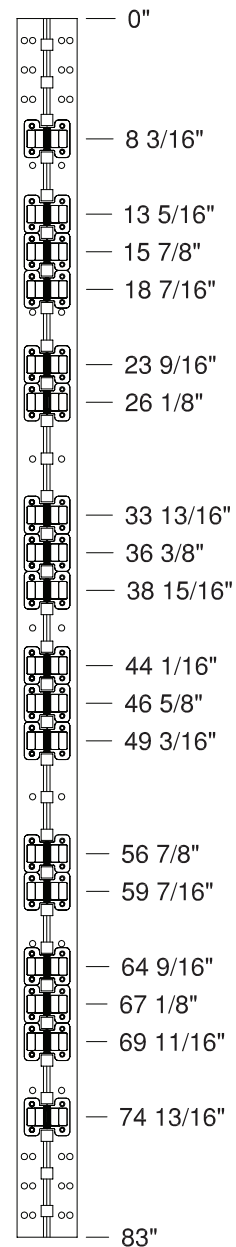
**For 83" HD300
Models SL11, SL14,
SL18, SL24**

ATW LOCATIONS



**For 83" HD600
Models SL11, SL14, SL18, SL24,
SL31, SL44, SL48, SL84**

ATW LOCATIONS



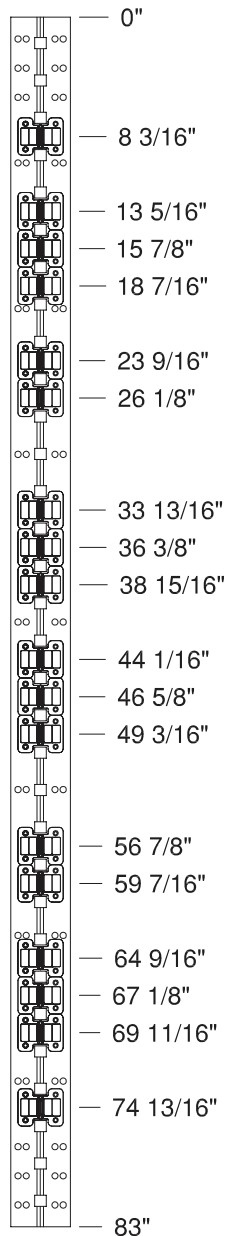
Concealed Geared Hinges

- All dimensions are measured in inches from the top of the door to the centerline of the ATW panels.
- Choose location for ATW prep. ATW4 = 1 location; ATW8 = 1 location; ATW12 = 1 location.

- Please visit www.select-hinges.com/specifications/templates for ATW location templates for SL12, SL26, and SL27 hinges.
- **NOTE:** For 90-degree openings, please specify at time of order for no upcharge. There will be an upcharge for 90-degree ATW cover plates when ordered separately and clear or bronze must be specified.

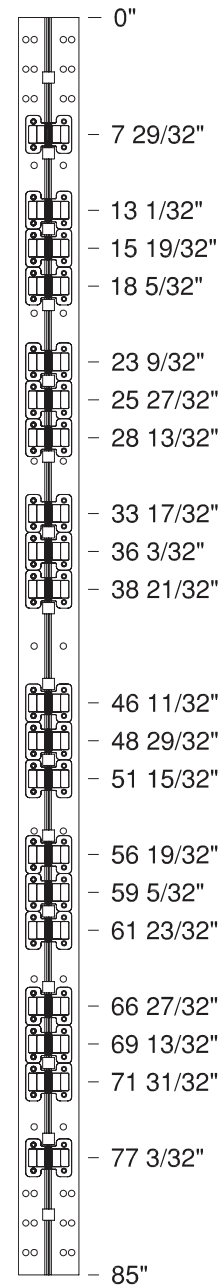
For 83" LL Models SL11, SL14, SL18, SL24, SL84

ATW LOCATIONS



For 85" HD300 Models SL11, SL14, SL18, SL24

ATW LOCATIONS

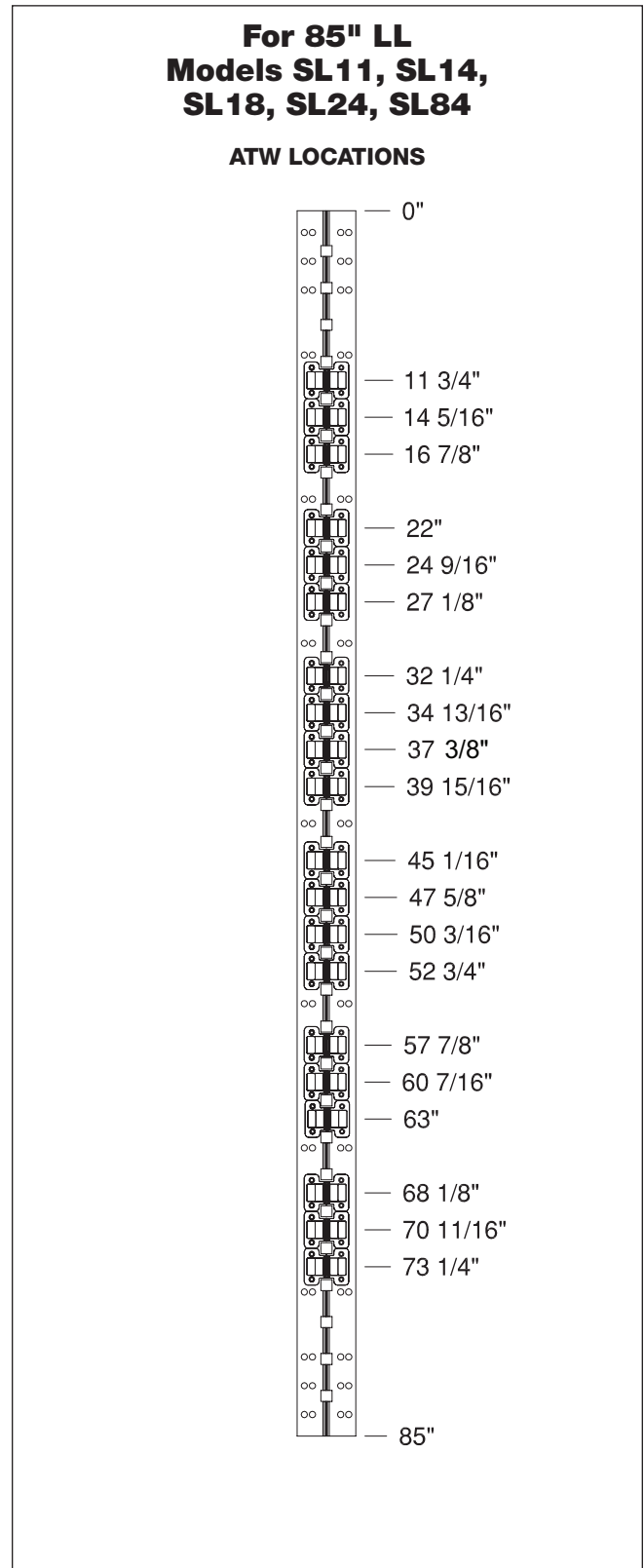
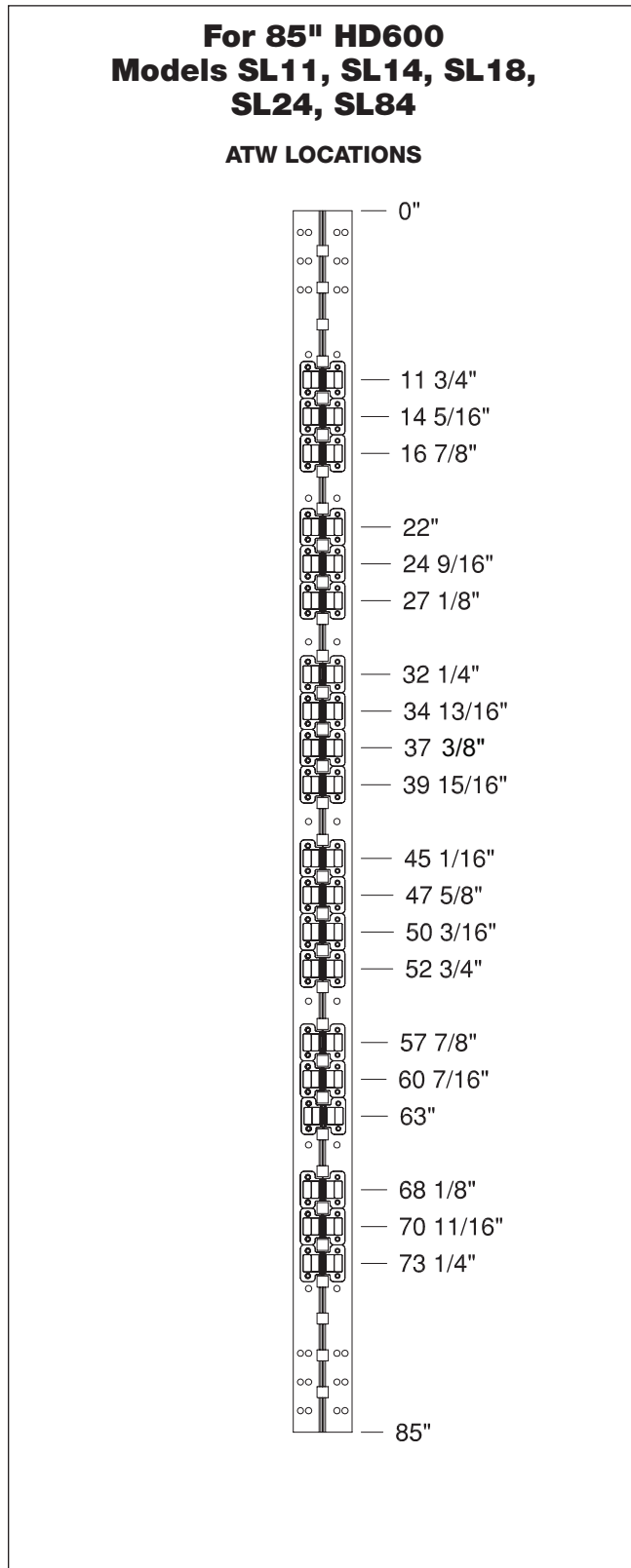


Concealed Geared Hinges



- All dimensions are measured in inches from the top of the door to the centerline of the ATW panels.
- Choose location for ATW prep. ATW4 = 1 location; ATW8 = 1 location; ATW12 = 1 location.

- Please visit www.select-hinges.com/specifications/templates for ATW location templates for SL12, SL26, and SL27 hinges.
- **NOTE:** For 90-degree openings, please specify at time of order for no upcharge. There will be an upcharge for 90-degree ATW cover plates when ordered separately and clear or bronze must be specified.



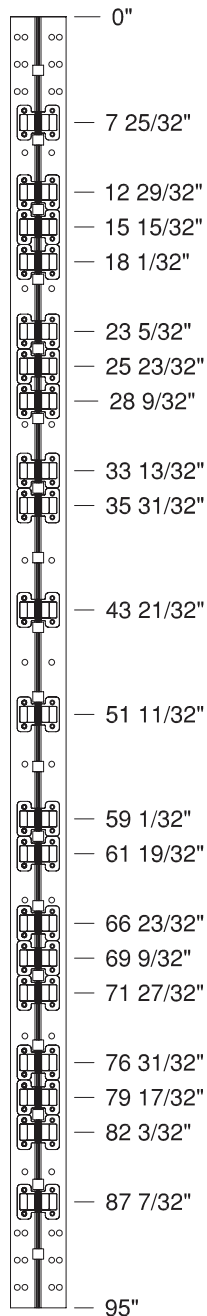
Concealed Geared Hinges

- All dimensions are measured in inches from the top of the door to the centerline of the ATW panels.
- Choose location for ATW prep. ATW4 = 1 location; ATW8 = 1 location; ATW12 = 1 location.

- Please visit www.select-hinges.com/specifications/templates for ATW location templates for SL12, SL26, and SL27 hinges.
- **NOTE:** For 90-degree openings, please specify at time of order for no upcharge. There will be an upcharge for 90-degree ATW cover plates when ordered separately and clear or bronze must be specified.

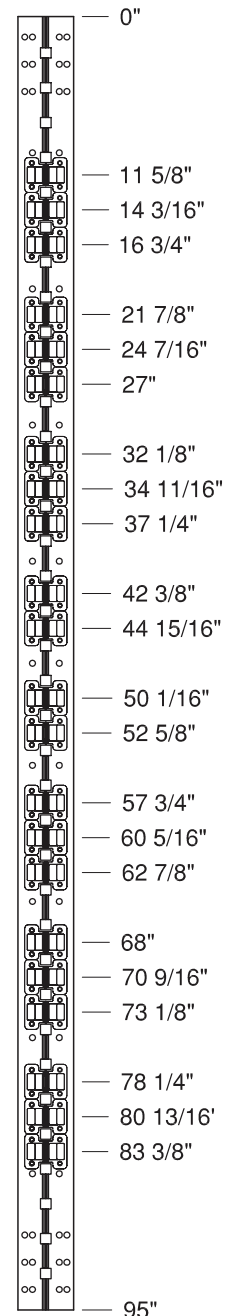
For 95" HD300 Models SL11, SL14, SL18, SL24

ATW LOCATIONS



For 95" HD600 Models SL11, SL14, SL18, SL24, SL31, SL44, SL48, SL84

ATW LOCATIONS



Concealed Geared Hinges

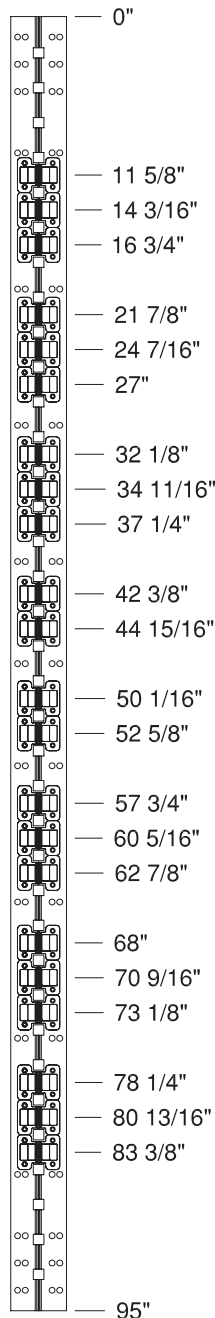


- All dimensions are measured in inches from the top of the door to the centerline of the ATW panels.
- Choose location for ATW prep. ATW4 = 1 location; ATW8 = 1 location; ATW12 = 1 location.

- Please visit www.select-hinges.com/specifications/templates for ATW location templates for SL12, SL26, and SL27 hinges.
- **NOTE:** For 90-degree openings, please specify at time of order for no upcharge. There will be an upcharge for 90-degree ATW cover plates when ordered separately and clear or bronze must be specified.

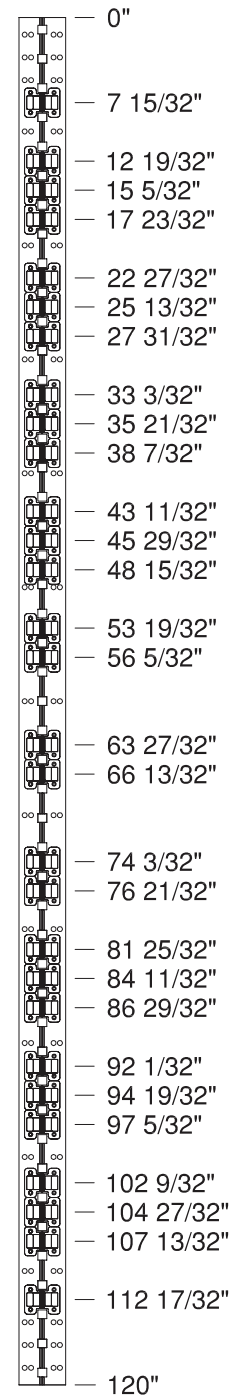
For 95" LL Models SL11, SL14, SL18, SL24, SL84

ATW LOCATIONS



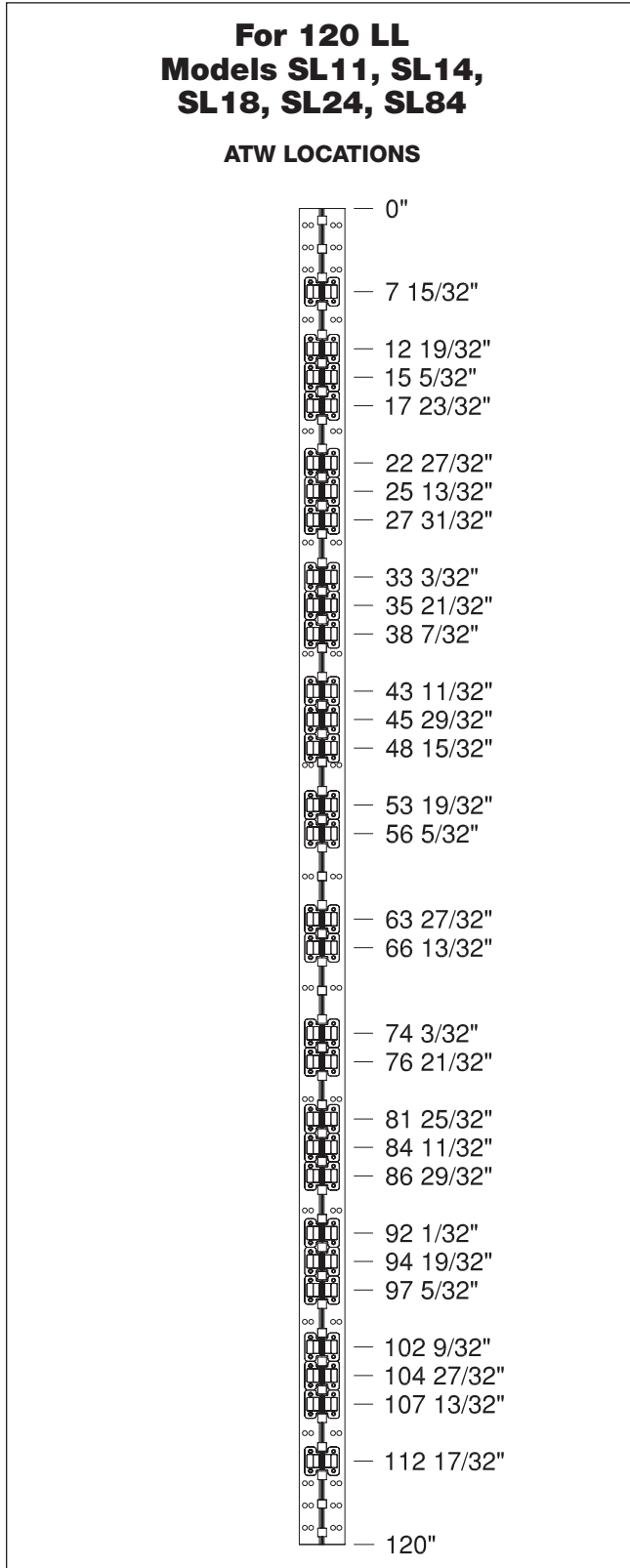
For 120" HD600 Models SL11, SL14, SL18, SL24, SL84

ATW LOCATIONS



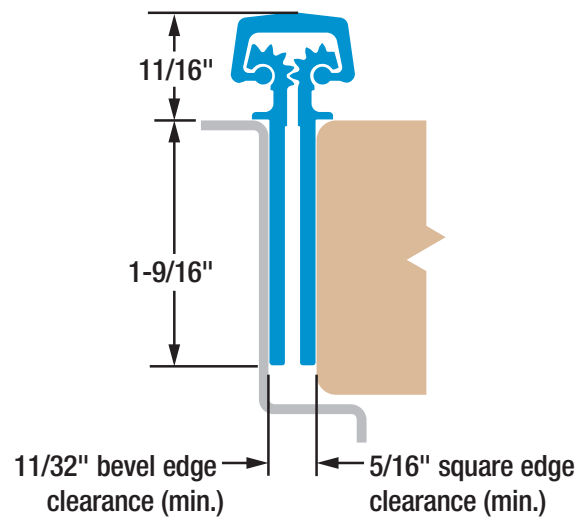
- All dimensions are measured in inches from the top of the door to the centerline of the ATW panels.
- Choose location for ATW prep. ATW4 = 1 location; ATW8 = 1 location; ATW12 = 1 location.

- Please visit www.select-hinges.com/specifications/templates for ATW location templates for SL12, SL26, and SL27 hinges.
- **NOTE:** For 90-degree openings, please specify at time of order for no upcharge. There will be an upcharge for 90-degree ATW cover plates when ordered separately and clear or bronze must be specified.





- Flush mounted (no door inset)
- For 1-3/4" doors



SL11 Concealed Geared Continuous Hinge



Tested to last six decades



Reduce maintenance costs and hassles. Independent lab tests on an FRP door prove

SELECT hinges withstand 25 million cycles — more than 60 years of high-traffic use. Pair-Matched™ hinge leaves, lifetime lubrication and anodizing after machining deliver the longest life of any continuous hinge.

Covered by the only Continuous Warranty



Because SELECT geared continuous hinges have proven themselves in independent testing, we offer the industry's only Continuous Warranty. It

covers any failure of our aluminum geared continuous hinges — with no expiration date — as long as they are properly installed. Durability and worry-free performance ... guaranteed in writing. *The warranty that never ends for the hinge that never quits.SM*

Certified by U.S. Department of State



After brutal testing, the State Department granted a SELECT geared continuous hinge its 60-minute certification — the department's highest level. The hinge deflected bullets in the Ballistic Resistance Test and withstood sledgehammers,

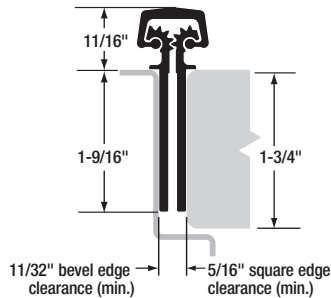
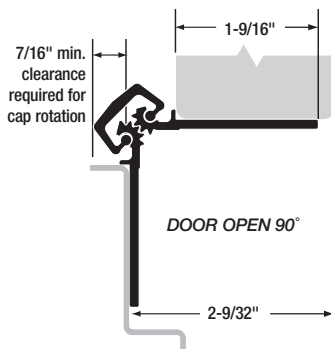
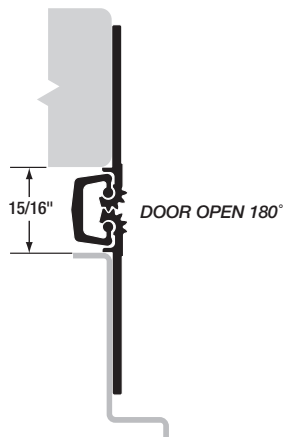
wedges and other tools in the Forced Entry Test. Approved for use in U.S. embassies overseas.

Geared to ship in 48 hours



SELECT ships hinges faster than anyone in the industry. 99.9% of our hinge orders ship in 48 hours; more than half are shipped in only 24 hours. Projects won't be delayed while waiting weeks for hinges.

NOTES:

SL11 Concealed Geared Continuous Hinge

DOOR CLOSED

DOOR OPEN 90°

DOOR OPEN 180°

MATERIAL: Extruded 6063 T6 aluminum alloy with self-lubricating polyester thrust bearings.

LENGTHS: 83", 85", 95" and 120" lengths standard for nominal door heights. Custom lengths are available.

LOAD/FREQUENCY RATINGS: For 1-3/4" doors. 48" max. door width in 16 gauge hollow metal (min.) or 1/8" aluminum (min.).

Heavy Duty 300 — For high-frequency doors up to 300 lb. without frame or door reinforcement.

Heavy Duty 600 — For high-frequency doors up to 600 lb. Rivnuts are recommended in the frame and door when the door exceeds 450 lb.

Heavy Duty (LL) — Our heavy duty 600 with additional fastener holes for low- to medium-frequency doors up to 1,000 lb., including most lead-lined doors. Rivnuts are recommended in the frame and door on extremely tall, extremely heavy or extra-wide doors.

FINISHES: All SL11 hinges are stocked in Clear, Dark Bronze and Black anodized aluminum. Custom anodized or painted finishes are available. Product painted or anodized in the field voids the SELECT hinge warranty.

CLOSERS: Conventional overhead surface, concealed sliding arm overhead or floor closers may be used with SELECT hinges. Pivot-type floor closers (with a fixed, conflicting center pivot) must be replaced.

ORDER: Specify length, finish and heavy duty 300 (HD300), heavy duty 600 (HD600) or heavy duty 600 with additional fastener holes (LL). Also, specify door and frame screw applications. 12-24 x 3/4" self-drilling, thread-forming 410SS Phillips undercut flathead screws are provided as a standard pack unless otherwise specified. Wood and thread-forming screws also available. Security screws optional at extra cost.

AVAILABLE ELECTRIC PREPS: EPT, ATW, EMS, CTW4, CTW5, CTW8, CTW10, CTW12, CMG, AP and RP.


SL11 HINGE SCREW COUNT

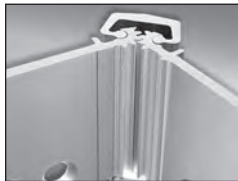
HINGE LENGTH & DUTY RATING	DOOR SCREWS	FRAME SCREWS
79" HD600	19	19
83" HD300/HD600	19	19
85" HD300/HD600	19	19
95" HD300/HD600	21	21
120" HD300/HD600	23	23
83" LL	26	26
85" LL	26	26
95" LL	30	30
120" LL	34	34

SELECT ADVANTAGES



PAIR-MATCHED™ HINGE LEAVES

Manufactured together, machined together and anodized together, making SELECT hinges fit your doors better and last longer. *An exclusive SELECT benefit.*



LIFETIME LUBRICATION

Eliminates the need for periodic maintenance. Quiet performance. Fights gear cap wear. *An exclusive SELECT benefit.*



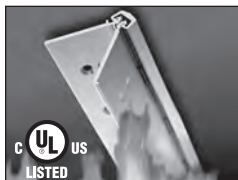
ANODIZED AFTER MACHINING

Delivers superior wear, durability and life. Inhibits corrosion. Few hinge makers follow SELECT's lead in using this superior manufacturing process.



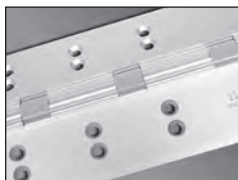
SUSTAINABLE

Made from up to 100% recycled aluminum. Reduces environmental impact and qualifies for LEED points. *An exclusive SELECT benefit.*



PATENTED 3-HR. FIRE RATING

Most SELECT hinges are fire rated for 90 minutes. 3-Hr. fire rating, optional at extra cost, approved for positive/negative pressure. No fire pins or studs required. Patented design innovation. *An exclusive SELECT benefit.*



CONSISTENT TEMPLATING

Hole pattern is identical on both Heavy Duty 300 and Heavy Duty 600 models, so SELECT hinges line up precisely for easier and faster installation. *An exclusive SELECT benefit.*



COATED FASTENERS

Provide additional corrosion protection with either self-drilling, thread-forming (SDTF) or thread-forming (TF) screws. *An exclusive SELECT benefit.*



CUSTOM COLORS

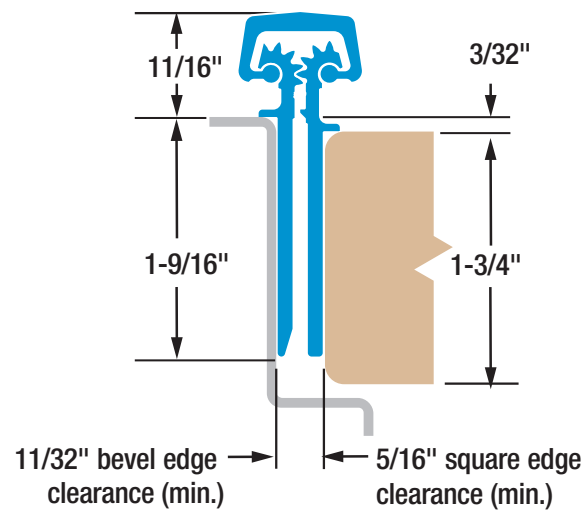
Match any paint color on the gear cap or the entire hinge and fasteners, including our always-in-stock Bone White gear caps. Anodized colors also available.

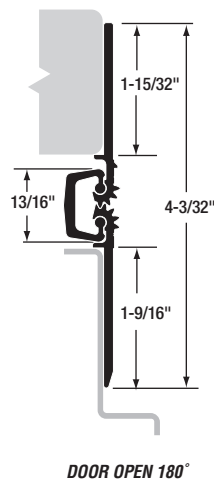
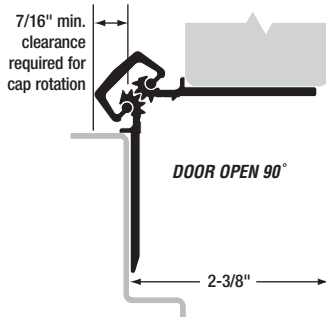
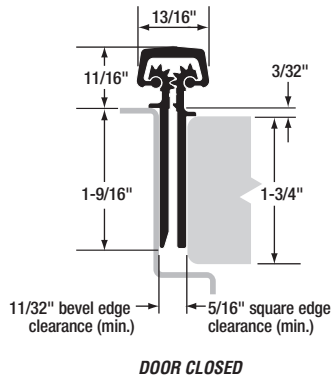
SELECT HINGE PERFORMANCE

- A SELECT geared continuous hinge has been tested in accordance with ANSI 250.4-1994 test procedure and acceptance criteria for physical endurance for steel doors and hardware and has surpassed 25,000,000 cycles during testing by an independent laboratory. On a door cycling 400,000 times per year, a SELECT hinge will be performing for over 62 years.
- SELECT geared continuous hinges are built to handle abuse from high-traffic applications. They are applied to the surface on the edge of the frame and door. No machining or reinforcement is required.
- The revolutionary SELECT geared continuous hinge puts an end to costly and irritating hinge failure problems, the most common cause of entrance failure.
- On conventional hinges, opening and “kick-back” energy concentrate on a few inches of fastened reinforcing plate — with the top hinge handling 100% of the force. Pinless SELECT hinges bond the door and frame into an integrated, sag-free unit. “Kick-back” energy dissipates along the entire length of the door and frame. (Compare this to a conventional hinge’s 4-1/2" to 5" at the top of the door and frame).
- SELECT geared continuous hinges eliminate the gap between the door and frame, providing a weatherproof, rust-proof, tamper-proof barrier. When the door is closed, there are no accessible screws, bolts or pins.
- SELECT SL11 geared continuous hinges are listed and tested by Underwriters Laboratories to meet the Positive and Negative pressure requirements of UL10B and UL10C, and are in accordance with UBC 7.2 (1997). SELECT SL11 geared continuous hinges are for use on swinging single fire doors (max. door opening of 4'x10') or pairs of fire doors (max. door opening of 8'x10'), including double egress, installed in masonry or drywall. SELECT SL11 geared continuous hinges are rated for up to 1-1/2 hours for wood composite and wood core type fire doors. A special patented process can be added to increase the fire rating to 3 hours (NO FIRE PINS OR STUDS REQUIRED) for hollow metal or steel covered composite type doors.



- Beveled frame leaf allows for weatherstripping or smoke seal
- Compatible with EFCO doors
- Staggered hole pattern
- 3/32" door inset
- For 1-3/4" doors



SL12 Concealed Geared Continuous Hinge


MATERIAL: Extruded 6063 T6 aluminum alloy with self-lubricating polyester thrust bearings.

LENGTHS: 83", 95" and 120" lengths standard for nominal door heights. Custom lengths are available.

LOAD/FREQUENCY RATINGS: For 1-3/4" doors. 48" max. door width in 16 gauge hollow metal (min.) or 1/8" aluminum (min.).

Heavy Duty 600 — For high-frequency doors up to 600 lb. Rivnuts are recommended in the frame and door when the door exceeds 450 lb.

FINISHES: All SL12 hinges are stocked in Clear and Dark Bronze anodized aluminum. Custom anodized or painted finishes are available. Product painted or anodized in the field voids the SELECT hinge warranty.

CLOSERS: Conventional overhead surface, concealed sliding arm overhead or floor closers may be used with SELECT hinges. Pivot-type floor closers (with a fixed, conflicting center pivot) must be replaced.

ORDER: Specify length, finish and heavy duty 600 (HD600). Also, specify door and frame screw applications. 12-24 x 3/4" self-drilling, thread-forming 410SS Phillips undercut flathead screws are provided as a standard pack unless otherwise specified. Wood and thread-forming screws also available. Security screws optional at extra cost.

AVAILABLE ELECTRIC PREPS: EPT, ATW, EMS, CTW4, CTW5, CTW8, CTW10, CTW12, CMG, AP and RP.


SL12 HINGE SCREW COUNT

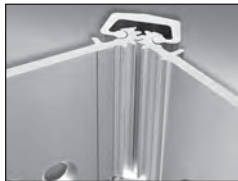
HINGE LENGTH & DUTY RATING	DOOR SCREWS	FRAME SCREWS
83" HD600	25	25
95" HD600	29	29
120" HD600	33	33

SELECT ADVANTAGES



PAIR-MATCHED™ HINGE LEAVES

Manufactured together, machined together and anodized together, making SELECT hinges fit your doors better and last longer. *An exclusive SELECT benefit.*



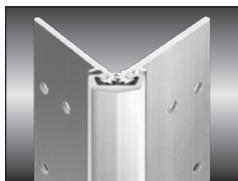
LIFETIME LUBRICATION

Eliminates the need for periodic maintenance. Quiet performance. Fights gear cap wear. *An exclusive SELECT benefit.*



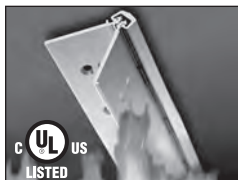
ANODIZED AFTER MACHINING

Delivers superior wear, durability and life. Inhibits corrosion. Few hinge makers follow SELECT's lead in using this superior manufacturing process.



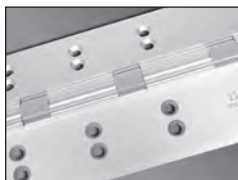
SUSTAINABLE

Made from up to 100% recycled aluminum. Reduces environmental impact and qualifies for LEED points. *An exclusive SELECT benefit.*



PATENTED 3-HR. FIRE RATING

Most SELECT hinges are fire rated for 90 minutes. 3-Hr. fire rating, optional at extra cost, approved for positive/negative pressure. No fire pins or studs required. Patented design innovation. *An exclusive SELECT benefit.*



CONSISTENT TEMPLATING

Hole pattern is identical on both Heavy Duty 300 and Heavy Duty 600 models, so SELECT hinges line up precisely for easier and faster installation. *An exclusive SELECT benefit.*



COATED FASTENERS

Provide additional corrosion protection with either self-drilling, thread-forming (SDTF) or thread-forming (TF) screws. *An exclusive SELECT benefit.*

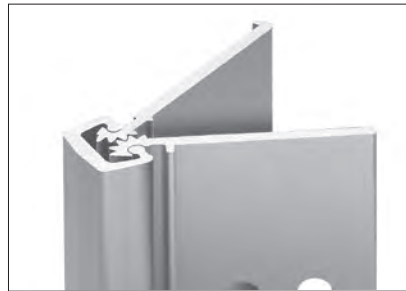


CUSTOM COLORS

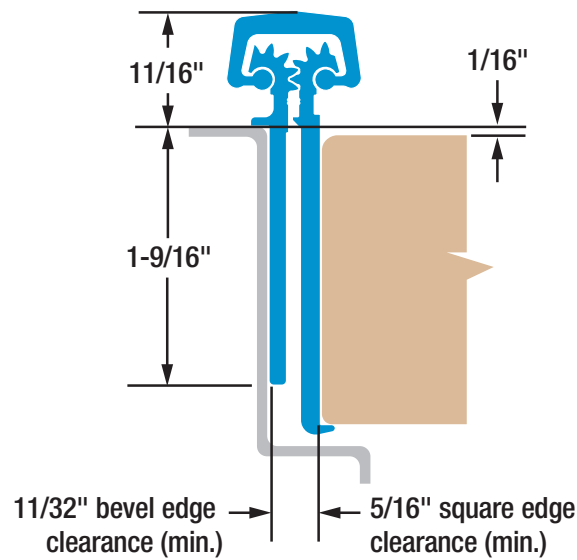
Match any paint color on the gear cap or the entire hinge and fasteners, including our always-in-stock Bone White gear caps. Anodized colors also available.

SELECT HINGE PERFORMANCE

- A SELECT geared continuous hinge has been tested in accordance with ANSI 250.4-1994 test procedure and acceptance criteria for physical endurance for steel doors and hardware and has surpassed 25,000,000 cycles during testing by an independent laboratory. On a door cycling 400,000 times per year, a SELECT hinge will be performing for over 62 years.
- SELECT geared continuous hinges are built to handle abuse from high-traffic applications. They are applied to the surface on the edge of the frame and door. No machining or reinforcement is required.
- The revolutionary SELECT geared continuous hinge puts an end to costly and irritating hinge failure problems, the most common cause of entrance failure.
- On conventional hinges, opening and “kick-back” energy concentrate on a few inches of fastened reinforcing plate — with the top hinge handling 100% of the force. Pinless SELECT hinges bond the door and frame into an integrated, sag-free unit. “Kick-back” energy dissipates along the entire length of the door and frame. (Compare this to a conventional hinge’s 4-1/2" to 5" at the top of the door and frame).
- SELECT geared continuous hinges eliminate the gap between the door and frame, providing a weatherproof, rust-proof, tamper-proof barrier. When the door is closed, there are no accessible screws, bolts or pins.
- SELECT SL12 geared continuous hinges are listed and tested by Underwriters Laboratories to meet the Positive and Negative pressure requirements of UL10B and UL10C, and are in accordance with UBC 7.2 (1997). SELECT SL12 geared continuous hinges are for use on swinging single fire doors (max. door opening of 4'x10') or pairs of fire doors (max. door opening of 8'x10'), including double egress, installed in masonry or drywall. SELECT SL12 geared continuous hinges are rated for up to 1-1/2 hours for wood composite and wood core type fire doors. A special patented process can be added to increase the fire rating to 3 hours (NO FIRE PINS OR STUDS REQUIRED) for hollow metal or steel covered composite type doors.



- Narrow frame leaf allows for weatherstripping or smoke seal
- Door edge protector
- 1/16" door inset
- For 1-3/4" doors



SL14 Concealed Geared Continuous Hinge



Tested to last six decades



Reduce maintenance costs and hassles. Independent lab tests on an FRP door prove

SELECT hinges withstand 25 million cycles — more than 60 years of high-traffic use. Pair-Matched™ hinge leaves, lifetime lubrication and anodizing after machining deliver the longest life of any continuous hinge.

Covered by the only Continuous Warranty



Because SELECT geared continuous hinges have proven themselves in independent testing, we offer the industry's only Continuous Warranty. It

covers any failure of our aluminum geared continuous hinges — with no expiration date — as long as they are properly installed. Durability and worry-free performance ... guaranteed in writing. *The warranty that never ends for the hinge that never quits.SM*

Certified by U.S. Department of State



After brutal testing, the State Department granted a SELECT geared continuous hinge its 60-minute certification — the department's highest level. The hinge deflected bullets in the Ballistic Resistance Test and withstood sledgehammers,

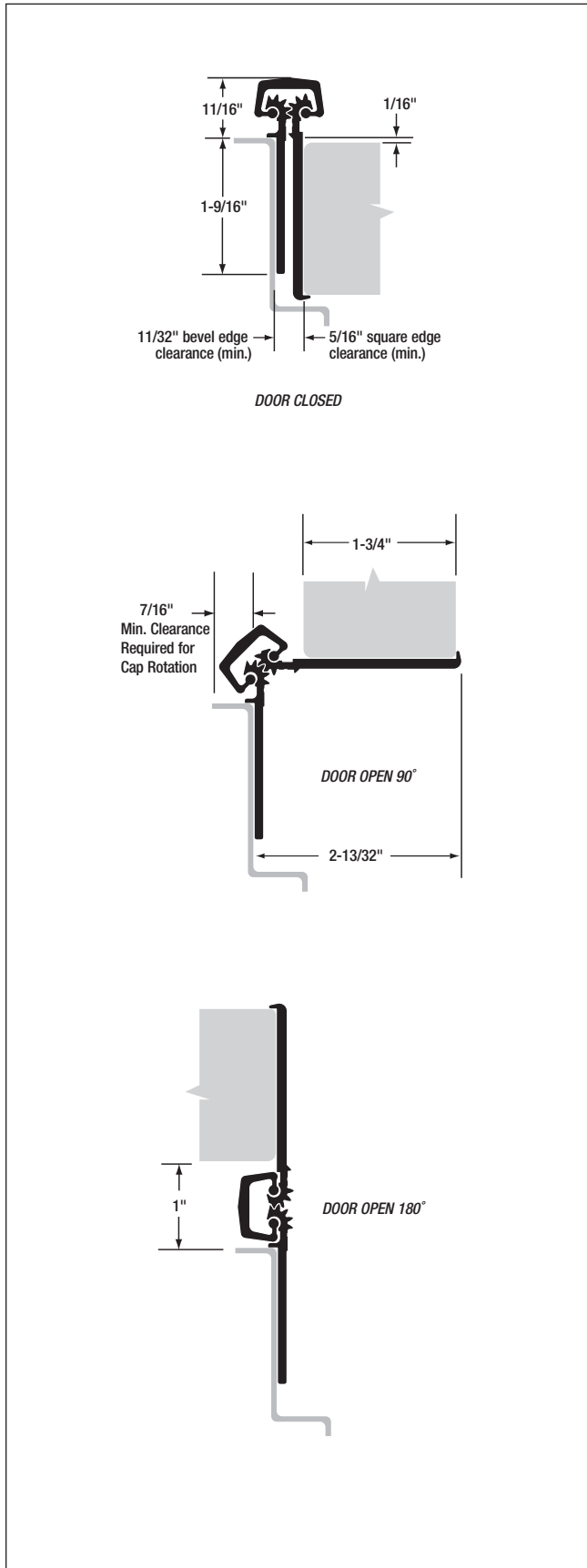
wedges and other tools in the Forced Entry Test. Approved for use in U.S. embassies overseas.

Geared to ship in 48 hours



SELECT ships hinges faster than anyone in the industry. 99.9% of our hinge orders ship in 48 hours; more than half are shipped in only 24 hours. Projects won't be delayed while waiting weeks for hinges.

NOTES:

SL14 Concealed Geared Continuous Hinge


MATERIAL: Extruded 6063 T6 aluminum alloy with self-lubricating polyester thrust bearings.

LENGTHS: 83", 85", 95" and 120" lengths standard for nominal door heights. Custom lengths are available.

LOAD/FREQUENCY RATINGS: For 1-3/4" doors. 48" max. door width in 16 gauge hollow metal (min.) or 1/8" aluminum (min.).

Heavy Duty 300 — For high-frequency doors up to 300 lb. without frame or door reinforcement.

Heavy Duty 600 — For high-frequency doors up to 600 lb. Rivnuts are recommended in the frame and door when the door exceeds 450 lb.

FINISHES: All SL14 hinges are stocked in Clear, Dark Bronze and Black anodized aluminum. Custom anodized or painted finishes are available. Product painted or anodized in the field voids the SELECT hinge warranty.

CLOSERS: Conventional overhead surface, concealed sliding arm overhead or floor closers may be used with SELECT hinges. Pivot-type floor closers (with a fixed, conflicting center pivot) must be replaced.

ORDER: Specify length, finish and heavy duty 300 (HD300) or heavy duty 600 (HD600). Also, specify door and frame screw applications. 12-24 x 3/4" self-drilling, thread-forming 410SS Phillips undercut flathead screws are provided as a standard pack unless otherwise specified. Wood and thread-forming screws also available. Security screws optional at extra cost.

AVAILABLE ELECTRIC PREPS: EPT, ATW, EMS, CTW4, CTW5, CTW8, CTW10, CTW12, CMG, AP and RP.



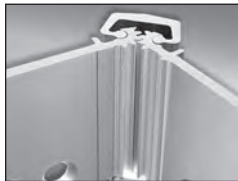
SL14 HINGE SCREW COUNT		
HINGE LENGTH & DUTY RATING	DOOR SCREWS	FRAME SCREWS
83" HD300/HD600	19	19
85" HD300/HD600	19	19
95" HD300/HD600	21	21
120" HD600	23	23

SELECT ADVANTAGES



PAIR-MATCHED™ HINGE LEAVES

Manufactured together, machined together and anodized together, making SELECT hinges fit your doors better and last longer. *An exclusive SELECT benefit.*



LIFETIME LUBRICATION

Eliminates the need for periodic maintenance. Quiet performance. Fights gear cap wear. *An exclusive SELECT benefit.*



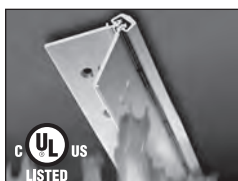
ANODIZED AFTER MACHINING

Delivers superior wear, durability and life. Inhibits corrosion. Few hinge makers follow SELECT's lead in using this superior manufacturing process.



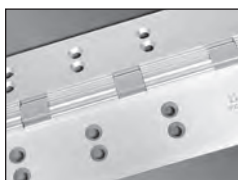
SUSTAINABLE

Made from up to 100% recycled aluminum. Reduces environmental impact and qualifies for LEED points. *An exclusive SELECT benefit.*



PATENTED 3-HR. FIRE RATING

Most SELECT hinges are fire rated for 90 minutes. 3-Hr. fire rating, optional at extra cost, approved for positive/negative pressure. No fire pins or studs required. Patented design innovation. *An exclusive SELECT benefit.*



CONSISTENT TEMPLATING

Hole pattern is identical on both Heavy Duty 300 and Heavy Duty 600 models, so SELECT hinges line up precisely for easier and faster installation. *An exclusive SELECT benefit.*



COATED FASTENERS

Provide additional corrosion protection with either self-drilling, thread-forming (SDTF) or thread-forming (TF) screws. *An exclusive SELECT benefit.*

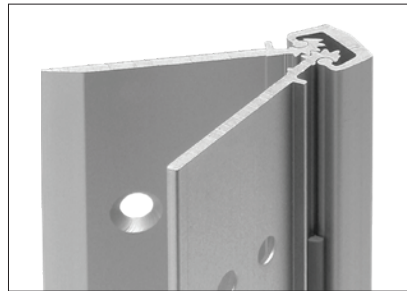


CUSTOM COLORS

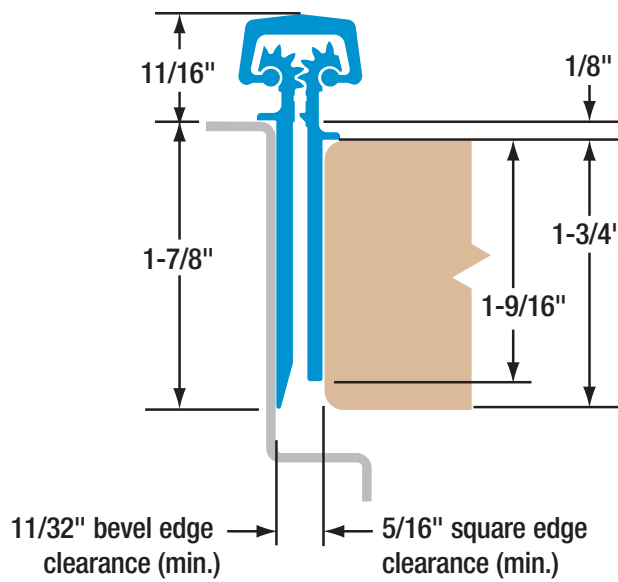
Match any paint color on the gear cap or the entire hinge and fasteners, including our always-in-stock Bone White gear caps. Anodized colors also available.

SELECT HINGE PERFORMANCE

- A SELECT geared continuous hinge has been tested in accordance with ANSI 250.4-1994 test procedure and acceptance criteria for physical endurance for steel doors and hardware and has surpassed 25,000,000 cycles during testing by an independent laboratory. On a door cycling 400,000 times per year, a SELECT hinge will be performing for over 62 years.
- SELECT geared continuous hinges are built to handle abuse from high-traffic applications. They are applied to the surface on the edge of the frame and door. No machining or reinforcement is required.
- The revolutionary SELECT geared continuous hinge puts an end to costly and irritating hinge failure problems, the most common cause of entrance failure.
- On conventional hinges, opening and “kick-back” energy concentrate on a few inches of fastened reinforcing plate — with the top hinge handling 100% of the force. Pinless SELECT hinges bond the door and frame into an integrated, sag-free unit. “Kick-back” energy dissipates along the entire length of the door and frame. (Compare this to a conventional hinge’s 4-1/2" to 5" at the top of the door and frame).
- SELECT SL14 geared continuous hinges eliminate the gap between the door and frame, providing a weatherproof, rust-proof, tamper-proof barrier. When the door is closed, there are no accessible screws, bolts or pins.
- SELECT SL14 geared continuous hinges are listed and tested by Underwriters Laboratories to meet the Positive and Negative pressure requirements of UL10B and UL10C, and are in accordance with UBC 7.2 (1997). SELECT SL14 geared continuous hinges are for use on swinging single fire doors (max. door opening of 4'x10') or pairs of fire doors (max. door opening of 8'x10'), including double egress, installed in masonry or drywall. SELECT SL14 geared continuous hinges are rated for up to 1-1/2 hours for wood composite and wood core type fire doors. A special patented process can be added to increase the fire rating to 3 hours (NO FIRE PINS OR STUDS REQUIRED) for hollow metal or steel covered composite type doors.



- Beveled frame leaf allows for weatherstripping or smoke seal
- 1/8" door inset
- For 1-3/4" doors



SL18 Concealed Geared Continuous Hinge



Tested to last six decades



Reduce maintenance costs and hassles. Independent lab tests on an FRP door prove

SELECT hinges withstand 25 million cycles — more than 60 years of high-traffic use. Pair-Matched™ hinge leaves, lifetime lubrication and anodizing after machining deliver the longest life of any continuous hinge.

Covered by the only Continuous Warranty



Because SELECT geared continuous hinges have proven themselves in independent testing, we offer the industry's only Continuous Warranty. It

covers any failure of our aluminum geared continuous hinges — with no expiration date — as long as they are properly installed. Durability and worry-free performance ... guaranteed in writing. *The warranty that never ends for the hinge that never quits.*SM

Certified by U.S. Department of State



After brutal testing, the State Department granted a SELECT geared continuous hinge its 60-minute certification — the department's highest level. The hinge deflected bullets in the Ballistic Resistance Test and withstood sledgehammers,

wedges and other tools in the Forced Entry Test. Approved for use in U.S. embassies overseas.

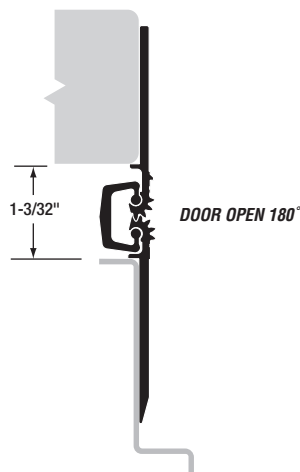
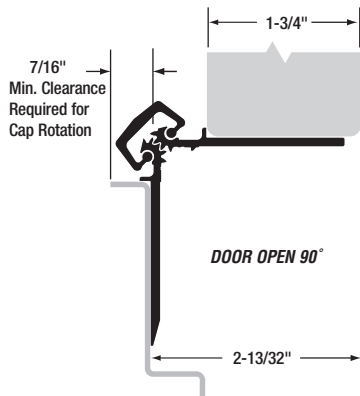
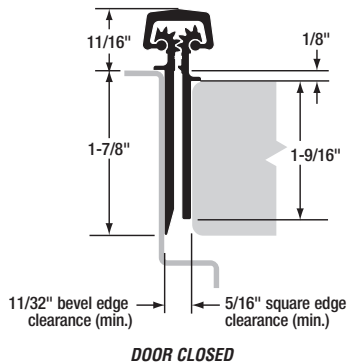
Geared to ship in 48 hours



SELECT ships hinges faster than anyone in the industry. 99.9% of our hinge orders ship in 48 hours; more than half are shipped in only 24 hours. Projects won't be delayed while waiting weeks for hinges.

NOTES:

Series of horizontal lines for notes.

SL18 Concealed Geared Continuous Hinge


MATERIAL: Extruded 6063 T6 aluminum alloy with self-lubricating polyester thrust bearings.

LENGTHS: 83", 85", 95" and 120" lengths standard for nominal door heights. Custom lengths are available.

LOAD/FREQUENCY RATINGS: For 1-3/4" doors. 48" max. door width in 16 gauge hollow metal (min.) or 1/8" aluminum (min.).

Heavy Duty 300 — For high-frequency doors up to 300 lb. without frame or door reinforcement.

Heavy Duty 600 — For high-frequency doors up to 600 lb. Rivnuts are recommended in the frame and door when the door exceeds 450 lb.

Heavy Duty (LL) — Our heavy duty 600 with additional fastener holes for low- to medium-frequency doors up to 1,000 lb., including most lead-lined doors. Rivnuts are recommended in the frame and door on extremely tall, extremely heavy or extra-wide doors.

FINISHES: All SL18 hinges are stocked in Clear, Dark Bronze and Black anodized aluminum. Custom anodized or painted finishes are available. Product painted or anodized in the field voids the SELECT hinge warranty.

CLOSERS: Conventional overhead surface, concealed sliding arm overhead or floor closers may be used with SELECT hinges. Pivot-type floor closers (with a fixed, conflicting center pivot) must be replaced.

ORDER: Specify length, finish and heavy duty 300 (HD300), heavy duty 600 (HD600) or heavy duty 600 with additional fastener holes (LL). Also, specify door and frame screw applications. 12-24 x 3/4" self-drilling, thread-forming 410SS Phillips undercut flathead screws are provided as a standard pack unless otherwise specified. Wood and thread-forming screws also available. Security screws optional at extra cost.

AVAILABLE ELECTRIC PREPS: EPT, ATW, EMS, CTW4, CTW5, CTW8, CTW10, CTW12, CMG, AP and RP.



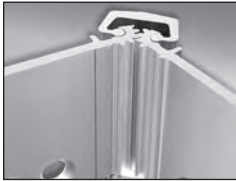
SL18 HINGE SCREW COUNT		
HINGE LENGTH & DUTY RATING	DOOR SCREWS	FRAME SCREWS
83" HD300/HD600	19	19
85" HD300/HD600	19	19
95" HD300/HD600	21	21
120" HD300/HD600	23	23
83" LL	26	26
85" LL	26	26
95" LL	30	30
120" LL	34	34

SELECT ADVANTAGES



PAIR-MATCHED™ HINGE LEAVES

Manufactured together, machined together and anodized together, making SELECT hinges fit your doors better and last longer. *An exclusive SELECT benefit.*



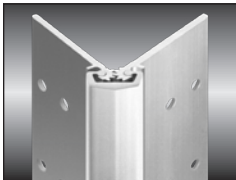
LIFETIME LUBRICATION

Eliminates the need for periodic maintenance. Quiet performance. Fights gear cap wear. *An exclusive SELECT benefit.*



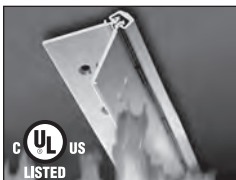
ANODIZED AFTER MACHINING

Delivers superior wear, durability and life. Inhibits corrosion. Few hinge makers follow SELECT's lead in using this superior manufacturing process.



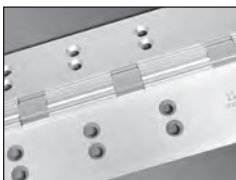
SUSTAINABLE

Made from up to 100% recycled aluminum. Reduces environmental impact and qualifies for LEED points. *An exclusive SELECT benefit.*



PATENTED 3-HR. FIRE RATING

Most SELECT hinges are fire rated for 90 minutes. 3-Hr. fire rating, optional at extra cost, approved for positive/negative pressure. No fire pins or studs required. Patented design innovation. *An exclusive SELECT benefit.*



CONSISTENT TEMPLATING

Hole pattern is identical on both Heavy Duty 300 and Heavy Duty 600 models, so SELECT hinges line up precisely for easier and faster installation. *An exclusive SELECT benefit.*



COATED FASTENERS

Provide additional corrosion protection with either self-drilling, thread-forming (SDTF) or thread-forming (TF) screws. *An exclusive SELECT benefit.*



CUSTOM COLORS

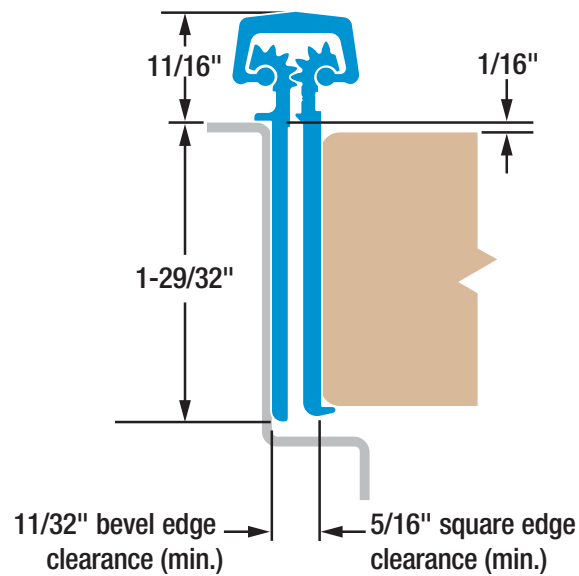
Match any paint color on the gear cap or the entire hinge and fasteners, including our always-in-stock Bone White gear caps. Anodized colors also available.

SELECT HINGE PERFORMANCE

- A SELECT geared continuous hinge has been tested in accordance with ANSI 250.4-1994 test procedure and acceptance criteria for physical endurance for steel doors and hardware and has surpassed 25,000,000 cycles during testing by an independent laboratory. On a door cycling 400,000 times per year, a SELECT hinge will be performing for over 62 years.
- SELECT geared continuous hinges are built to handle abuse from high-traffic applications. They are applied to the surface on the edge of the frame and door. No machining or reinforcement is required.
- The revolutionary SELECT geared continuous hinge puts an end to costly and irritating hinge failure problems, the most common cause of entrance failure.
- On conventional hinges, opening and “kick-back” energy concentrate on a few inches of fastened reinforcing plate — with the top hinge handling 100% of the force. Pinless SELECT hinges bond the door and frame into an integrated, sag-free unit. “Kick-back” energy dissipates along the entire length of the door and frame. (Compare this to a conventional hinge’s 4-1/2" to 5" at the top of the door and frame).
- SELECT geared continuous hinges eliminate the gap between the door and frame, providing a weatherproof, rust-proof, tamper-proof barrier. When the door is closed, there are no accessible screws, bolts or pins.
- SELECT SL18 geared continuous hinges are listed and tested by Underwriters Laboratories to meet the Positive and Negative pressure requirements of UL10B and UL10C, and are in accordance with UBC 7.2 (1997). SELECT SL18 geared continuous hinges are for use on swinging single fire doors (max. door opening of 4'x10') or pairs of fire doors (max. door opening of 8'x10'), including double egress, installed in masonry or drywall. SELECT SL18 geared continuous hinges are rated for up to 1-1/2 hours for wood composite and wood core type fire doors. A special patented process can be added to increase the fire rating to 3 hours (NO FIRE PINS OR STUDS REQUIRED) for hollow metal or steel covered composite type doors.



- Door edge protector
- Frame leaf covers butt hinge preps
- 1/16" door inset
- For 1-3/4" doors



SL24 Concealed Geared Continuous Hinge



SL24

Tested to last six decades



Reduce maintenance costs and hassles. Independent lab tests on an FRP door prove

SELECT hinges withstand 25 million cycles — more than 60 years of high-traffic use. Pair-Matched™ hinge leaves, lifetime lubrication and anodizing after machining deliver the longest life of any continuous hinge.

Covered by the only Continuous Warranty



Because SELECT geared continuous hinges have proven themselves in independent testing, we offer the industry's only Continuous Warranty. It

covers any failure of our aluminum geared continuous hinges — with no expiration date — as long as they are properly installed. Durability and worry-free performance ... guaranteed in writing. *The warranty that never ends for the hinge that never quits.SM*

Certified by U.S. Department of State



After brutal testing, the State Department granted a SELECT geared continuous hinge its 60-minute certification — the department's highest level. The hinge deflected bullets in the Ballistic Resistance Test and withstood sledgehammers,

wedges and other tools in the Forced Entry Test. Approved for use in U.S. embassies overseas.

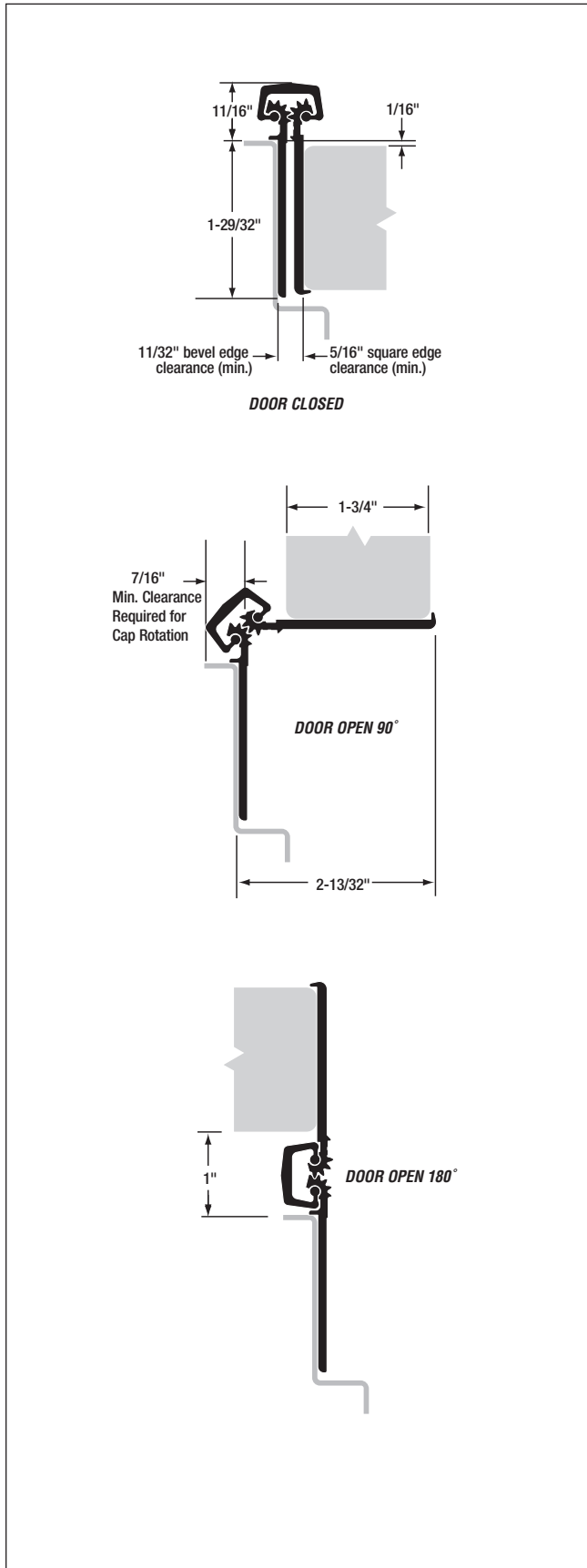
Geared to ship in 48 hours

Geared to ship in



SELECT ships hinges faster than anyone in the industry. 99.9% of our hinge orders ship in 48 hours; more than half are shipped in only 24 hours. Projects won't be delayed while waiting weeks for hinges.

NOTES:

SL24 Concealed Geared Continuous Hinge


MATERIAL: Extruded 6063 T6 aluminum alloy with self-lubricating polyester thrust bearings.

LENGTHS: 83", 85", 95" and 120" lengths standard for nominal door heights. Custom lengths are available.

LOAD/FREQUENCY RATINGS: For 1-3/4" doors. 48" max. door width in 16 gauge hollow metal (min.) or 1/8" aluminum (min.).

Heavy Duty 300 — For high-frequency doors up to 300 lb. without frame or door reinforcement.

Heavy Duty 600 — For high-frequency doors up to 600 lb. Rivnuts are recommended in the frame and door when the door exceeds 450 lb.

Heavy Duty (LL) — Our heavy duty 600 with additional fastener holes for low- to medium-frequency doors up to 1,000 lb., including most lead-lined doors. Rivnuts are recommended in the frame and door on extremely tall, extremely heavy or extra-wide doors.

FINISHES: All SL24 hinges are stocked in Clear, Dark Bronze and Black anodized aluminum. Custom anodized or painted finishes are available. Product painted or anodized in the field voids the SELECT hinge warranty.

CLOSERS: Conventional overhead surface, concealed sliding arm overhead or floor closers may be used with SELECT hinges. Pivot-type floor closers (with a fixed, conflicting center pivot) must be replaced.

ORDER: Specify length, finish and heavy duty 300 (HD300), heavy duty 600 (HD600) or heavy duty 600 with additional fastener holes (LL). Also, specify door and frame screw applications. 12-24 x 3/4" self-drilling, thread-forming 410SS Phillips undercut flathead screws are provided as a standard pack unless otherwise specified. Wood and thread-forming screws also available. Security screws optional at extra cost.

AVAILABLE ELECTRIC PREPS: EPT, ATW, EMS, CTW4, CTW5, CTW8, CTW10, CTW12, CMG, AP and RP.



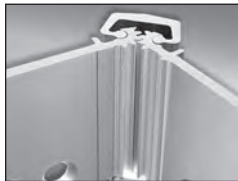
SL24 HINGE SCREW COUNT		
HINGE LENGTH & DUTY RATING	DOOR SCREWS	FRAME SCREWS
79" HD600	19	19
83" HD300/HD600	19	19
85" HD300/HD600	19	19
95" HD300/HD600	21	21
120" HD300/HD600	23	23
83" LL	26	26
85" LL	26	26
95" LL	30	30
120" LL	34	34

SELECT ADVANTAGES



PAIR-MATCHED™ HINGE LEAVES

Manufactured together, machined together and anodized together, making SELECT hinges fit your doors better and last longer. *An exclusive SELECT benefit.*



LIFETIME LUBRICATION

Eliminates the need for periodic maintenance. Quiet performance. Fights gear cap wear. *An exclusive SELECT benefit.*



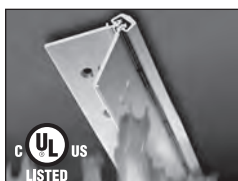
ANODIZED AFTER MACHINING

Delivers superior wear, durability and life. Inhibits corrosion. Few hinge makers follow SELECT's lead in using this superior manufacturing process.



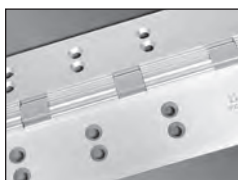
SUSTAINABLE

Made from up to 100% recycled aluminum. Reduces environmental impact and qualifies for LEED points. *An exclusive SELECT benefit.*



PATENTED 3-HR. FIRE RATING

Most SELECT hinges are fire rated for 90 minutes. 3-Hr. fire rating, optional at extra cost, approved for positive/negative pressure. No fire pins or studs required. Patented design innovation. *An exclusive SELECT benefit.*



CONSISTENT TEMPLATING

Hole pattern is identical on both Heavy Duty 300 and Heavy Duty 600 models, so SELECT hinges line up precisely for easier and faster installation. *An exclusive SELECT benefit.*



COATED FASTENERS

Provide additional corrosion protection with either self-drilling, thread-forming (SDTF) or thread-forming (TF) screws. *An exclusive SELECT benefit.*

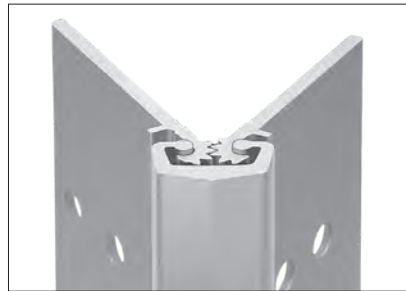


CUSTOM COLORS

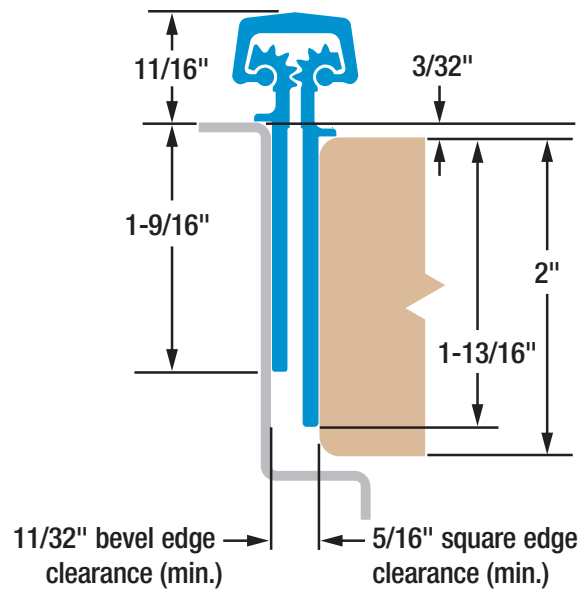
Match any paint color on the gear cap or the entire hinge and fasteners, including our always-in-stock Bone White gear caps. Anodized colors also available.

SELECT HINGE PERFORMANCE

- A SELECT geared continuous hinge has been tested in accordance with ANSI 250.4-1994 test procedure and acceptance criteria for physical endurance for steel doors and hardware and has surpassed 25,000,000 cycles during testing by an independent laboratory. On a door cycling 400,000 times per year, a SELECT hinge will be performing for over 62 years.
- SELECT geared continuous hinges are built to handle abuse from high-traffic applications. They are applied to the surface on the edge of the frame and door. No machining or reinforcement is required.
- The revolutionary SELECT geared continuous hinge puts an end to costly and irritating hinge failure problems, the most common cause of entrance failure.
- On conventional hinges, opening and “kick-back” energy concentrate on a few inches of fastened reinforcing plate — with the top hinge handling 100% of the force. Pinless SELECT hinges bond the door and frame into an integrated, sag-free unit. “Kick-back” energy dissipates along the entire length of the door and frame. (Compare this to a conventional hinge’s 4-1/2" to 5" at the top of the door and frame).
- SELECT geared continuous hinges eliminate the gap between the door and frame, providing a weatherproof, rust-proof, tamper-proof barrier. When the door is closed, there are no accessible screws, bolts or pins.
- SELECT SL24 geared continuous hinges are listed and tested by Underwriters Laboratories to meet the Positive and Negative pressure requirements of UL10B and UL10C, and are in accordance with UBC 7.2 (1997). SELECT SL24 geared continuous hinges are for use on swinging single fire doors (max. door opening of 4'x10') or pairs of fire doors (max. door opening of 8'x10'), including double egress, installed in masonry or drywall. SELECT SL24 geared continuous hinges are rated for up to 1-1/2 hours for wood composite and wood core type fire doors. A special patented process can be added to increase the fire rating to 3 hours (NO FIRE PINS OR STUDS REQUIRED) for hollow metal or steel covered composite type doors.



- For 2" to 2-1/4" doors
- Narrow frame leaf
- Staggered hole pattern
- For doors up to 1,000 lb.
- 3/32" door inset



SL26 Concealed Geared Continuous Hinge



Tested to last six decades



Reduce maintenance costs and hassles. Independent lab tests on an FRP door prove

SELECT hinges withstand 25 million cycles — more than 60 years of high-traffic use. Pair-Matched™ hinge leaves, lifetime lubrication and anodizing after machining deliver the longest life of any continuous hinge.

Covered by the only Continuous Warranty



Because SELECT geared continuous hinges have proven themselves in independent testing, we offer the industry's only Continuous Warranty. It

covers any failure of our aluminum geared continuous hinges — with no expiration date — as long as they are properly installed. Durability and worry-free performance ... guaranteed in writing. *The warranty that never ends for the hinge that never quits.*SM

Certified by U.S. Department of State



After brutal testing, the State Department granted a SELECT geared continuous hinge its 60-minute certification — the department's highest level. The hinge deflected bullets in the Ballistic Resistance Test and withstood sledgehammers,

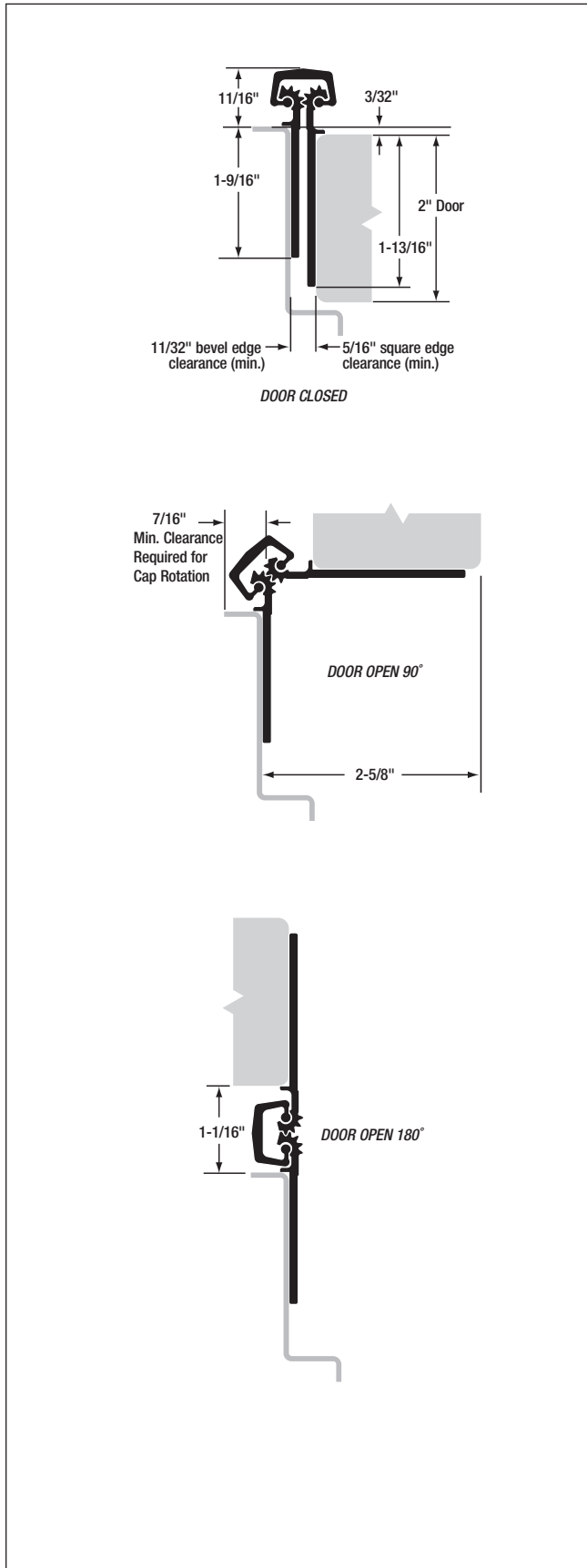
wedges and other tools in the Forced Entry Test. Approved for use in U.S. embassies overseas.

Geared to ship in 48 hours



SELECT ships hinges faster than anyone in the industry. 99.9% of our hinge orders ship in 48 hours; more than half are shipped in only 24 hours. Projects won't be delayed while waiting weeks for hinges.

NOTES:

SL26 Concealed Geared Continuous Hinge


MATERIAL: Extruded 6063 T6 aluminum alloy with self-lubricating polyester thrust bearings.

LENGTHS: 83", 85", 95" and 120" lengths standard for nominal door heights. Custom lengths are available.

LOAD/FREQUENCY RATING: For 2" to 2-1/4" doors. 48" max. door width in 16 gauge hollow metal (min.) or 1/8" aluminum (min.).

Heavy Duty LL — Our heavy duty 600 with additional fastener holes for low- to medium-frequency doors up to 1,000 lb., including most lead-lined doors. Rivnuts are recommended in the frame and door on extremely tall, extremely heavy or extra-wide doors.

FINISHES: All SL26 hinges are stocked in Clear and Dark Bronze anodized aluminum. Custom anodized or painted finishes are available. Product painted or anodized in the field voids the SELECT hinge warranty.

CLOSERS: Conventional overhead surface, concealed sliding arm overhead or floor closers may be used with SELECT hinges. Pivot-type floor closers (with a fixed, conflicting center pivot) must be replaced.

ORDER: Specify length, finish and heavy duty 600 with additional fastener holes (LL). Also, specify door and frame screw applications. 12-24 x 3/4" self-drilling, thread-forming 410SS Phillips undercut flathead screws are provided as a standard pack unless otherwise specified. Wood and thread-forming screws also available. Security screws optional at extra cost.

AVAILABLE ELECTRIC PREPS: EPT, ATW, EMS, CTW4, CTW5, CTW8, CTW10, CTW12, CMG, AP and RP.



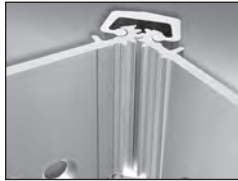
SL26 HINGE SCREW COUNT		
HINGE LENGTH & DUTY RATING	DOOR SCREWS	FRAME SCREWS
83" LL	25	25
85" LL	25	25
95" LL	29	29
120" LL	33	33

SELECT ADVANTAGES



PAIR-MATCHED™ HINGE LEAVES

Manufactured together, machined together and anodized together, making SELECT hinges fit your doors better and last longer. *An exclusive SELECT benefit.*



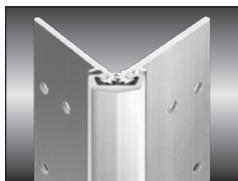
LIFETIME LUBRICATION

Eliminates the need for periodic maintenance. Quiet performance. Fights gear cap wear. *An exclusive SELECT benefit.*



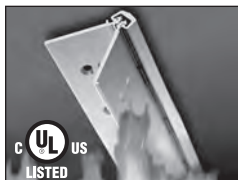
ANODIZED AFTER MACHINING

Delivers superior wear, durability and life. Inhibits corrosion. Few hinge makers follow SELECT's lead in using this superior manufacturing process.



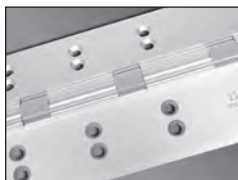
SUSTAINABLE

Made from up to 100% recycled aluminum. Reduces environmental impact and qualifies for LEED points. *An exclusive SELECT benefit.*



PATENTED 3-HR. FIRE RATING

Most SELECT hinges are fire rated for 90 minutes. 3-Hr. fire rating, optional at extra cost, approved for positive/negative pressure. No fire pins or studs required. Patented design innovation. *An exclusive SELECT benefit.*



CONSISTENT TEMPLATING

Hole pattern is identical on both Heavy Duty 300 and Heavy Duty 600 models, so SELECT hinges line up precisely for easier and faster installation. *An exclusive SELECT benefit.*



COATED FASTENERS

Provide additional corrosion protection with either self-drilling, thread-forming (SDTF) or thread-forming (TF) screws. *An exclusive SELECT benefit.*

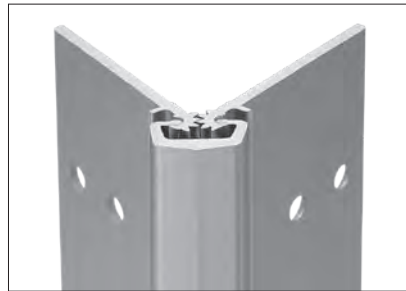


CUSTOM COLORS

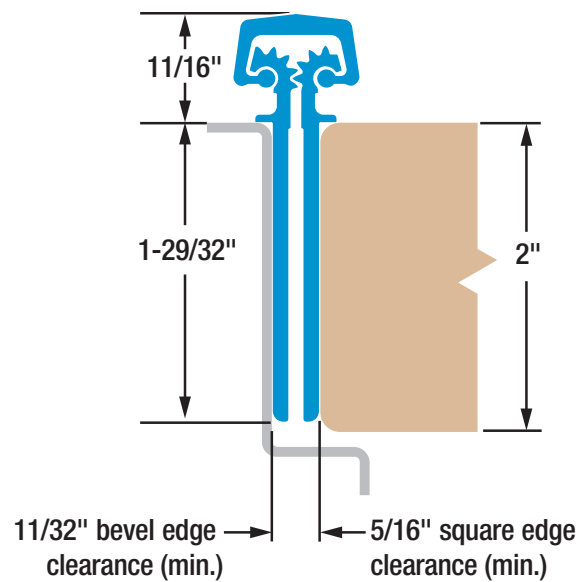
Match any paint color on the gear cap or the entire hinge and fasteners, including our always-in-stock Bone White gear caps. Anodized colors also available.

SELECT HINGE PERFORMANCE

- A SELECT geared continuous hinge has been tested in accordance with ANSI 250.4-1994 test procedure and acceptance criteria for physical endurance for steel doors and hardware and has surpassed 25,000,000 cycles during testing by an independent laboratory. On a door cycling 400,000 times per year, a SELECT hinge will be performing for over 62 years.
- SELECT geared continuous hinges are built to handle abuse from high-traffic applications. They are applied to the surface on the edge of the frame and door. No machining or reinforcement is required.
- The revolutionary SELECT geared continuous hinge puts an end to costly and irritating hinge failure problems, the most common cause of entrance failure.
- On conventional hinges, opening and “kick-back” energy concentrate on a few inches of fastened reinforcing plate — with the top hinge handling 100% of the force. Pinless SELECT hinges bond the door and frame into an integrated, sag-free unit. “Kick-back” energy dissipates along the entire length of the door and frame. (Compare this to a conventional hinge’s 4-1/2" to 5" at the top of the door and frame).
- SELECT geared continuous hinges eliminate the gap between the door and frame, providing a weatherproof, rust-proof, tamper-proof barrier. When the door is closed, there are no accessible screws, bolts or pins.
- SELECT SL26 geared continuous hinges are listed and tested by Underwriters Laboratories to meet the Positive and Negative pressure requirements of UL10B and UL10C, and are in accordance with UBC 7.2 (1997). SELECT SL26 geared continuous hinges are for use on swinging single fire doors (max. door opening of 4'x10') or pairs of fire doors (max. door opening of 8'x10'), including double egress, installed in masonry or drywall. SELECT SL26 geared continuous hinges are rated for up to 1-1/2 hours for wood composite and wood core type fire doors. A special patented process can be added to increase the fire rating to 3 hours (NO FIRE PINS OR STUDS REQUIRED) for hollow metal or steel covered composite type doors.



- For 2" to 2-1/4" doors
- Frame leaf covers butt hinge preps
- Staggered hole pattern
- For doors up to 1,000 lb.
- Flush mounted (no door inset)



SL27

Concealed Geared Continuous Hinge



Tested to last six decades



Reduce maintenance costs and hassles. Independent lab tests on an FRP door prove

SELECT hinges withstand 25 million cycles — more than 60 years of high-traffic use. Pair-Matched™ hinge leaves, lifetime lubrication and anodizing after machining deliver the longest life of any continuous hinge.

Covered by the only Continuous Warranty



Because SELECT geared continuous hinges have proven themselves in independent testing, we offer the industry's only Continuous Warranty. It

covers any failure of our aluminum geared continuous hinges — with no expiration date — as long as they are properly installed. Durability and worry-free performance ... guaranteed in writing. *The warranty that never ends for the hinge that never quits.SM*

Certified by U.S. Department of State



After brutal testing, the State Department granted a SELECT geared continuous hinge its 60-minute certification — the department's highest level. The hinge deflected bullets in the Ballistic Resistance Test and withstood sledgehammers,

wedges and other tools in the Forced Entry Test. Approved for use in U.S. embassies overseas.

Geared to ship in 48 hours

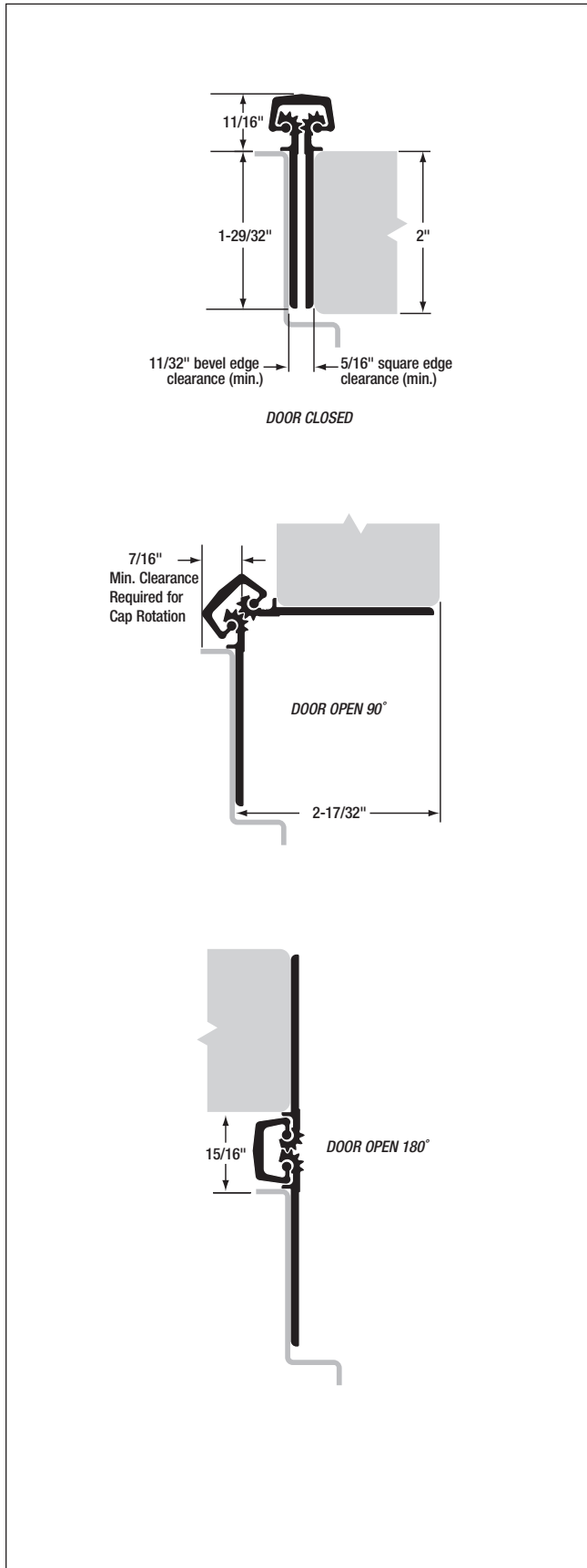
Geared to ship in



SELECT ships hinges faster than anyone in the industry. 99.9% of our hinge orders ship in 48 hours; more than half are shipped in only 24 hours. Projects won't be delayed while waiting weeks for hinges.

NOTES:

Horizontal lines for handwritten notes.

SL27 Concealed Geared Continuous Hinge


MATERIAL: Extruded 6063 T6 aluminum alloy with self-lubricating polyester thrust bearings.

LENGTHS: 83", 85", 95" and 120" lengths standard for nominal door heights. Custom lengths are available.

LOAD/FREQUENCY RATING: For 2" to 2-1/4" doors. 48" max. door width in 16 gauge hollow metal (min.) or 1/8" aluminum (min.).

Heavy Duty LL — Our heavy duty 600 with additional fastener holes for low- to medium-frequency doors up to 1,000 lb., including most lead-lined doors. Rivnuts are recommended in the frame and door on extremely tall, extremely heavy or extra-wide doors.

FINISHES: All SL27 hinges are stocked in Clear, Dark Bronze and Black anodized aluminum. Custom anodized or painted finishes are available. Product painted or anodized in the field voids the SELECT hinge warranty.

CLOSERS: Conventional overhead surface, concealed sliding arm overhead or floor closers may be used with SELECT hinges. Pivot-type floor closers (with a fixed, conflicting center pivot) must be replaced.

ORDER: Specify length, finish and heavy duty 600 with additional fastener holes (LL). Also, specify door and frame screw applications. 12-24 x 3/4" self-drilling, thread-forming 410SS Phillips undercut flathead screws are provided as a standard pack unless otherwise specified. Wood and thread-forming screws also available. Security screws optional at extra cost.

AVAILABLE ELECTRIC PREPS: EPT, ATW, EMS, CTW4, CTW5, CTW8, CTW10, CTW12, CMG, AP and RP.



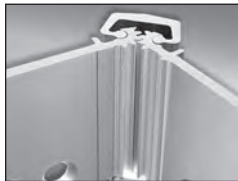
SL27 HINGE SCREW COUNT		
HINGE LENGTH & DUTY RATING	DOOR SCREWS	FRAME SCREWS
83" LL	25	25
85" LL	25	25
95" LL	29	29
120" LL	33	33

SELECT ADVANTAGES



PAIR-MATCHED™ HINGE LEAVES

Manufactured together, machined together and anodized together, making SELECT hinges fit your doors better and last longer. *An exclusive SELECT benefit.*



LIFETIME LUBRICATION

Eliminates the need for periodic maintenance. Quiet performance. Fights gear cap wear. *An exclusive SELECT benefit.*



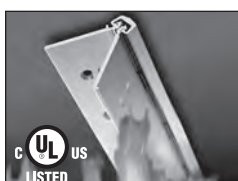
ANODIZED AFTER MACHINING

Delivers superior wear, durability and life. Inhibits corrosion. Few hinge makers follow SELECT's lead in using this superior manufacturing process.



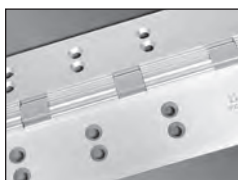
SUSTAINABLE

Made from up to 100% recycled aluminum. Reduces environmental impact and qualifies for LEED points. *An exclusive SELECT benefit.*



PATENTED 3-HR. FIRE RATING

Most SELECT hinges are fire rated for 90 minutes. 3-Hr. fire rating, optional at extra cost, approved for positive/negative pressure. No fire pins or studs required. Patented design innovation. *An exclusive SELECT benefit.*



CONSISTENT TEMPLATING

Hole pattern is identical on both Heavy Duty 300 and Heavy Duty 600 models, so SELECT hinges line up precisely for easier and faster installation. *An exclusive SELECT benefit.*



COATED FASTENERS

Provide additional corrosion protection with either self-drilling, thread-forming (SDTF) or thread-forming (TF) screws. *An exclusive SELECT benefit.*



CUSTOM COLORS

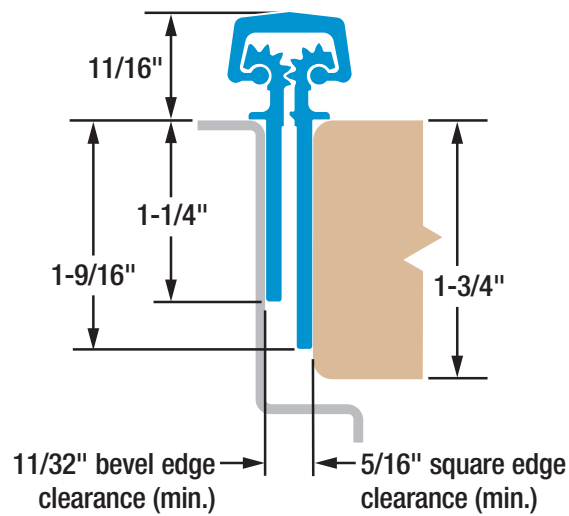
Match any paint color on the gear cap or the entire hinge and fasteners, including our always-in-stock Bone White gear caps. Anodized colors also available.

SELECT HINGE PERFORMANCE

- A SELECT geared continuous hinge has been tested in accordance with ANSI 250.4-1994 test procedure and acceptance criteria for physical endurance for steel doors and hardware and has surpassed 25,000,000 cycles during testing by an independent laboratory. On a door cycling 400,000 times per year, a SELECT hinge will be performing for over 62 years.
- SELECT geared continuous hinges are built to handle abuse from high-traffic applications. They are applied to the surface on the edge of the frame and door. No machining or reinforcement is required.
- The revolutionary SELECT geared continuous hinge puts an end to costly and irritating hinge failure problems, the most common cause of entrance failure.
- On conventional hinges, opening and “kick-back” energy concentrate on a few inches of fastened reinforcing plate — with the top hinge handling 100% of the force. Pinless SELECT hinges bond the door and frame into an integrated, sag-free unit. “Kick-back” energy dissipates along the entire length of the door and frame. (Compare this to a conventional hinge’s 4-1/2" to 5" at the top of the door and frame).
- SELECT geared continuous hinges eliminate the gap between the door and frame, providing a weatherproof, rust-proof, tamper-proof barrier. When the door is closed, there are no accessible screws, bolts or pins.
- SELECT SL27 geared continuous hinges are listed and tested by Underwriters Laboratories to meet the Positive and Negative pressure requirements of UL10B and UL10C, and are in accordance with UBC 7.2 (1997). SELECT SL27 geared continuous hinges are for use on swinging single fire doors (max. door opening of 4'x10') or pairs of fire doors (max. door opening of 8'x10'), including double egress, installed in masonry or drywall. SELECT SL27 geared continuous hinges are rated for up to 1-1/2 hours for wood composite and wood core type fire doors. A special patented process can be added to increase the fire rating to 3 hours (NO FIRE PINS OR STUDS REQUIRED) for hollow metal or steel covered composite type doors.



- Short frame leaf allows for removable stop applications
- Flush mounted (no door inset)
- For 1-3/4" doors



SL31 Concealed Geared Continuous Hinge



Tested to last six decades



Reduce maintenance costs and hassles. Independent lab tests on an FRP door prove

SELECT hinges withstand 25 million cycles — more than 60 years of high-traffic use. Pair-Matched™ hinge leaves, lifetime lubrication and anodizing after machining deliver the longest life of any continuous hinge.

Covered by the only Continuous Warranty



Because SELECT geared continuous hinges have proven themselves in independent testing, we offer the industry's only Continuous Warranty. It

covers any failure of our aluminum geared continuous hinges — with no expiration date — as long as they are properly installed. Durability and worry-free performance ... guaranteed in writing. *The warranty that never ends for the hinge that never quits.SM*

Certified by U.S. Department of State



After brutal testing, the State Department granted a SELECT geared continuous hinge its 60-minute certification — the department's highest level. The hinge deflected bullets in the Ballistic Resistance Test and withstood sledgehammers,

wedges and other tools in the Forced Entry Test. Approved for use in U.S. embassies overseas.

Geared to ship in 48 hours

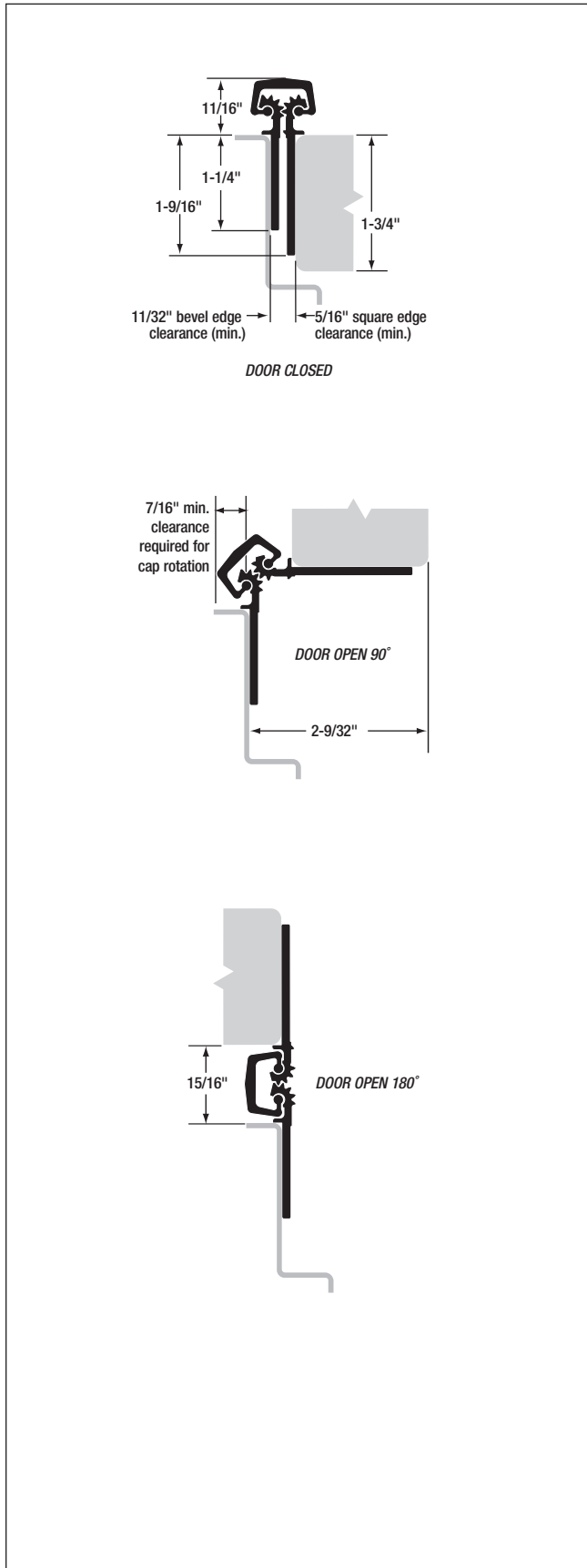
Geared to ship in



SELECT ships hinges faster than anyone in the industry. 99.9% of our hinge orders ship in 48 hours; more than half are shipped in only 24 hours. Projects won't be delayed while waiting weeks for hinges.

NOTES:

SL31 Concealed Geared Continuous Hinge



MATERIAL: Extruded 6063 T6 aluminum alloy with self-lubricating polyester thrust bearings.

LENGTHS: 83", 95" and 120" lengths standard for nominal door heights. Hinges can be cut to shorter lengths. Longer hinges are not available.

LOAD/FREQUENCY RATING: For 1-3/4" doors. 48" max. door width in 16 gauge hollow metal (min.) or 1/8" aluminum (min.).

Heavy Duty 600 — For high-frequency doors up to 600 lb. Rivnuts are recommended in the frame and door when the door exceeds 450 lb.

FINISHES: All SL31 hinges are stocked in Clear, Dark Bronze and Black anodized aluminum. Custom anodized or painted finishes are available. Product painted or anodized in the field voids the SELECT hinge warranty.

CLOSERS: Conventional overhead surface, concealed sliding arm overhead or floor closers may be used with SELECT hinges. Pivot-type floor closers (with a fixed, conflicting center pivot) must be replaced.

ORDER: Specify length, finish and heavy duty 600 (HD600). Also, specify door and frame screw applications. 12-24 x 3/4" self-drilling, thread-forming 410SS Phillips undercut flathead screws are provided as a standard pack unless otherwise specified. Wood and thread-forming screws also available. Security screws optional at extra cost.

AVAILABLE ELECTRIC PREPS: EPT, ATW, EMS, CTW4, CTW5, CTW8, CTW10, CTW12, CMG, AP and RP.



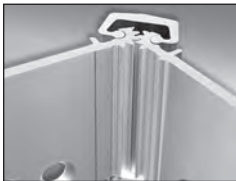
SL31 HINGE SCREW COUNT		
HINGE LENGTH & DUTY RATING	DOOR SCREWS	FRAME SCREWS
83" HD600	19	19
95" HD600	21	21
120" HD600	23	23

SELECT ADVANTAGES



PAIR-MATCHED™ HINGE LEAVES

Manufactured together, machined together and anodized together, making SELECT hinges fit your doors better and last longer. *An exclusive SELECT benefit.*



LIFETIME LUBRICATION

Eliminates the need for periodic maintenance. Quiet performance. Fights gear cap wear. *An exclusive SELECT benefit.*



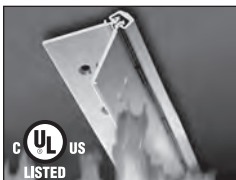
ANODIZED AFTER MACHINING

Delivers superior wear, durability and life. Inhibits corrosion. Few hinge makers follow SELECT's lead in using this superior manufacturing process.



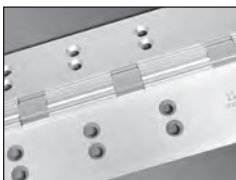
SUSTAINABLE

Made from up to 100% recycled aluminum. Reduces environmental impact and qualifies for LEED points. *An exclusive SELECT benefit.*



PATENTED 3-HR. FIRE RATING

Most SELECT hinges are fire rated for 90 minutes. 3-Hr. fire rating, optional at extra cost, approved for positive/negative pressure. No fire pins or studs required. Patented design innovation. *An exclusive SELECT benefit.*



CONSISTENT TEMPLATING

Hole pattern is identical on both Heavy Duty 300 and Heavy Duty 600 models, so SELECT hinges line up precisely for easier and faster installation. *An exclusive SELECT benefit.*



COATED FASTENERS

Provide additional corrosion protection with either self-drilling, thread-forming (SDTF) or thread-forming (TF) screws. *An exclusive SELECT benefit.*

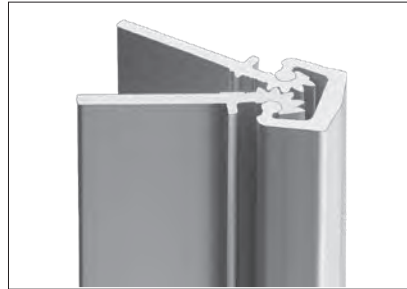


CUSTOM COLORS

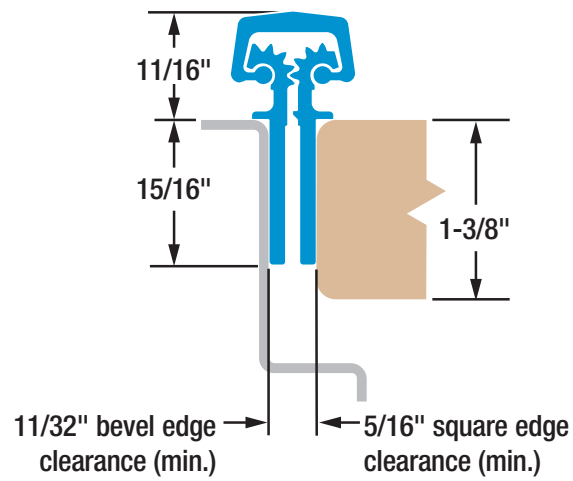
Match any paint color on the gear cap or the entire hinge and fasteners, including our always-in-stock Bone White gear caps. Anodized colors also available.

SELECT HINGE PERFORMANCE

- A SELECT geared continuous hinge has been tested in accordance with ANSI 250.4-1994 test procedure and acceptance criteria for physical endurance for steel doors and hardware and has surpassed 25,000,000 cycles during testing by an independent laboratory. On a door cycling 400,000 times per year, a SELECT hinge will be performing for over 62 years.
- SELECT geared continuous hinges are built to handle abuse from high-traffic applications. They are applied to the surface on the edge of the frame and door. No machining or reinforcement is required.
- The revolutionary SELECT geared continuous hinge puts an end to costly and irritating hinge failure problems, the most common cause of entrance failure.
- On conventional hinges, opening and “kick-back” energy concentrate on a few inches of fastened reinforcing plate — with the top hinge handling 100% of the force. Pinless SELECT hinges bond the door and frame into an integrated, sag-free unit. “Kick-back” energy dissipates along the entire length of the door and frame. (Compare this to a conventional hinge’s 4-1/2" to 5" at the top of the door and frame).
- SELECT geared continuous hinges eliminate the gap between the door and frame, providing a weatherproof, rust-proof, tamper-proof barrier. When the door is closed, there are no accessible screws, bolts or pins.
- SELECT SL31 geared continuous hinges are listed and tested by Underwriters Laboratories to meet the Positive and Negative pressure requirements of UL10B and UL10C, and are in accordance with UBC 7.2 (1997). SELECT SL31 geared continuous hinges are for use on swinging single fire doors (max. door opening of 4'x10') or pairs of fire doors (max. door opening of 8'x10'), including double egress, installed in masonry or drywall. SELECT SL31 geared continuous hinges are rated for up to 1-1/2 hours for wood composite and wood core type fire doors. A special patented process can be added to increase the fire rating to 3 hours (NO FIRE PINS OR STUDS REQUIRED) for hollow metal or steel covered composite type doors.



- For 1" to 1-3/8" doors
- Flush mounted (no door inset)



SL38

Concealed Geared Continuous Hinge



Tested to last six decades



Reduce maintenance costs and hassles. Independent lab tests on an FRP door prove

SELECT hinges withstand 25 million cycles — more than 60 years of high-traffic use. Pair-Matched™ hinge leaves, lifetime lubrication and anodizing after machining deliver the longest life of any continuous hinge.

Covered by the only Continuous Warranty



Because SELECT geared continuous hinges have proven themselves in independent testing, we offer the industry's only Continuous Warranty. It

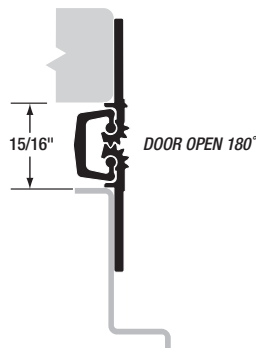
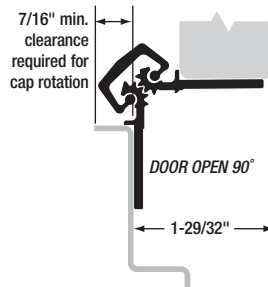
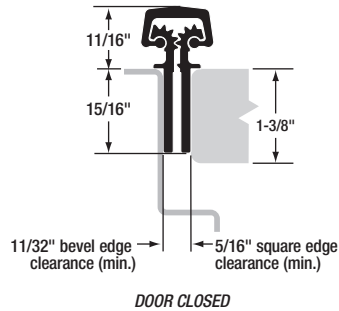
covers any failure of our aluminum geared continuous hinges — with no expiration date — as long as they are properly installed. Durability and worry-free performance ... guaranteed in writing. *The warranty that never ends for the hinge that never quits.*SM

Geared to ship in 48 hours



SELECT ships hinges faster than anyone in the industry. 99.9% of our hinge orders ship in 48 hours; more than half are shipped in only 24 hours. Projects won't be delayed while waiting weeks for hinges.

NOTES:

SL38 Concealed Geared Continuous Hinge


MATERIAL: Extruded 6063 T6 aluminum alloy with self-lubricating polyester thrust bearings.

LENGTHS: 83" and 95" lengths standard for nominal door heights. Hinges can be cut to shorter lengths. Longer hinges are not available.

LOAD/FREQUENCY RATING: For 1" to 1-3/8" doors. 48" max. door width in 16 gauge hollow metal (min.) or 1/8" aluminum (min.).

Heavy Duty 300 – For high-frequency doors up to 300 lb. without frame or door reinforcement.

FINISHES: All SL38 hinges are stocked in Clear and Dark Bronze anodized aluminum. Custom anodized or painted finishes are available. Product painted or anodized in the field voids the SELECT hinge warranty.

CLOSERS: Conventional overhead surface, concealed sliding arm overhead or floor closers may be used with SELECT hinges. Pivot-type floor closers (with a fixed, conflicting center pivot) must be replaced.

ORDER: Specify length, finish and heavy duty 300 (HD300). Also, specify door and frame screw applications. 12-24 x 3/4" self-drilling, thread-forming 410SS Phillips undercut flathead screws are provided as a standard pack unless otherwise specified. Wood and thread-forming screws also available. Security screws optional at extra cost.

AVAILABLE ELECTRIC PREPS: EMS, AP and RP.

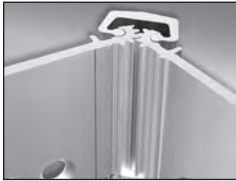
SL38 HINGE SCREW COUNT		
HINGE LENGTH & DUTY RATING	DOOR SCREWS	FRAME SCREWS
83" HD300	11	11
95" HD300	11	11

SELECT ADVANTAGES



PAIR-MATCHED™ HINGE LEAVES

Manufactured together, machined together and anodized together, making SELECT hinges fit your doors better and last longer. *An exclusive SELECT benefit.*



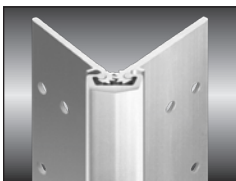
LIFETIME LUBRICATION

Eliminates the need for periodic maintenance. Quiet performance. Fights gear cap wear. *An exclusive SELECT benefit.*



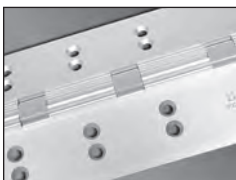
ANODIZED AFTER MACHINING

Delivers superior wear, durability and life. Inhibits corrosion. Few hinge makers follow SELECT's lead in using this superior manufacturing process.



SUSTAINABLE

Made from up to 100% recycled aluminum. Reduces environmental impact and qualifies for LEED points. *An exclusive SELECT benefit.*



CONSISTENT TEMPLATING

Hole pattern is identical on both Heavy Duty 300 and Heavy Duty 600 models, so SELECT hinges line up precisely for easier and faster installation. *An exclusive SELECT benefit.*



COATED FASTENERS

Provide additional corrosion protection with either self-drilling, thread-forming (SDTF) or thread-forming (TF) screws. *An exclusive SELECT benefit.*



CUSTOM COLORS

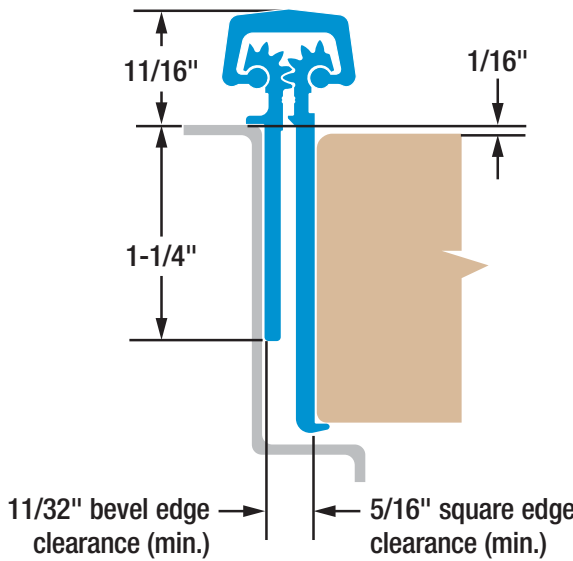
Match any paint color on the gear cap or the entire hinge and fasteners, including our always-in-stock Bone White gear caps. Anodized colors also available.

SELECT HINGE PERFORMANCE

- A SELECT geared continuous hinge has been tested in accordance with ANSI 250.4-1994 test procedure and acceptance criteria for physical endurance for steel doors and hardware and has surpassed 25,000,000 cycles during testing by an independent laboratory. On a door cycling 400,000 times per year, a SELECT hinge will be performing for over 62 years.
- SELECT geared continuous hinges are built to handle abuse from high-traffic applications. They are applied to the surface on the edge of the frame and door. No machining or reinforcement is required.
- The revolutionary SELECT geared continuous hinge puts an end to costly and irritating hinge failure problems, the most common cause of entrance failure.
- On conventional hinges, opening and “kick-back” energy concentrate on a few inches of fastened reinforcing plate — with the top hinge handling 100% of the force. Pinless SELECT hinges bond the door and frame into an integrated, sag-free unit. “Kick-back” energy dissipates along the entire length of the door and frame. (Compare this to a conventional hinge’s 4-1/2" to 5" at the top of the door and frame).
- SELECT geared continuous hinges eliminate the gap between the door and frame, providing a weatherproof, rust-proof, tamper-proof barrier. When the door is closed, there are no accessible screws, bolts or pins.
- SELECT SL38 geared continuous hinges are listed and tested by Underwriters Laboratories to meet the Positive and Negative pressure requirements of UL10B and UL10C, and are in accordance with UBC 7.2 (1997). SELECT SL38 geared continuous hinges are for use on swinging single fire doors (max. door opening of 4'x10') or pairs of fire doors (max. door opening of 8'x10'), including double egress, installed in masonry or drywall. SELECT SL38 geared continuous hinges are rated for up to 1-1/2 hours for wood composite and wood core type fire doors.



- Short frame leaf allows for removable stop applications
- Door edge protector
- 1/16" door inset
- For 1-3/4" doors



SL44

Concealed Geared Continuous Hinge



Tested to last six decades



Reduce maintenance costs and hassles. Independent lab tests on an FRP door prove

SELECT hinges withstand 25 million cycles — more than 60 years of high-traffic use. Pair-Matched™ hinge leaves, lifetime lubrication and anodizing after machining deliver the longest life of any continuous hinge.

Covered by the only Continuous Warranty



Because SELECT geared continuous hinges have proven themselves in independent testing, we offer the industry's only Continuous Warranty. It

covers any failure of our aluminum geared continuous hinges — with no expiration date — as long as they are properly installed. Durability and worry-free performance ... guaranteed in writing. *The warranty that never ends for the hinge that never quits.*SM

Certified by U.S. Department of State



After brutal testing, the State Department granted a SELECT geared continuous hinge its 60-minute certification — the department's highest level. The hinge deflected bullets in the Ballistic Resistance Test and withstood sledgehammers,

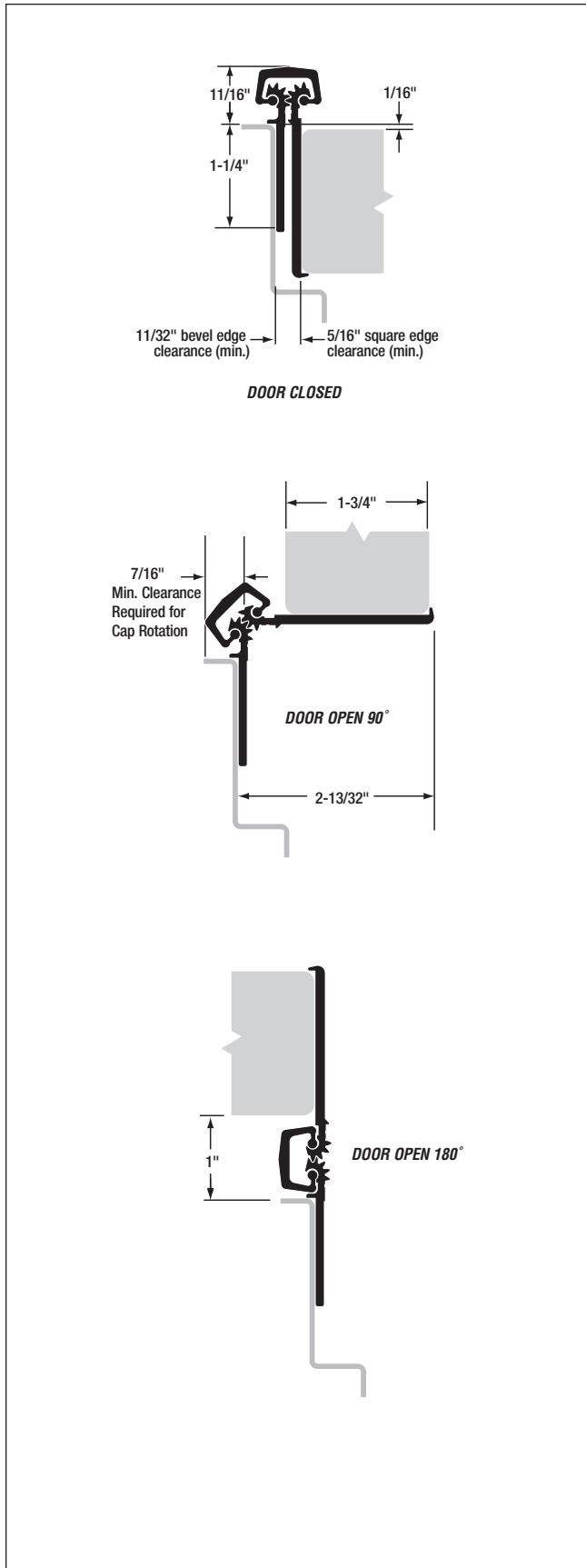
wedges and other tools in the Forced Entry Test. Approved for use in U.S. embassies overseas.

Geared to ship in 48 hours



SELECT ships hinges faster than anyone in the industry. 99.9% of our hinge orders ship in 48 hours; more than half are shipped in only 24 hours. Projects won't be delayed while waiting weeks for hinges.

NOTES:

SL44 Concealed Geared Continuous Hinge


MATERIAL: Extruded 6063 T6 aluminum alloy with self-lubricating polyester thrust bearings.

LENGTHS: 83" and 95" lengths standard for nominal door heights. Hinges can be cut to shorter lengths. Longer hinges are not available.

LOAD/FREQUENCY RATING: For 1-3/4" doors. 48" max. door width in 16 gauge hollow metal (min.) or 1/8" aluminum (min.).

Heavy Duty 600 — For high-frequency doors up to 600 lb. Rivnuts are recommended in the frame and door when the door exceeds 450 lb.

FINISHES: All SL44 hinges are stocked in Clear and Dark Bronze anodized aluminum. Custom anodized or painted finishes are available. Product painted or anodized in the field voids the SELECT hinge warranty.

CLOSERS: Conventional overhead surface, concealed sliding arm overhead or floor closers may be used with SELECT hinges. Pivot-type floor closers (with a fixed, conflicting center pivot) must be replaced.

ORDER: Specify length, finish and heavy duty 600 (HD600). Also, specify door and frame screw applications. 12-24 x 3/4" self-drilling, thread-forming 410SS Phillips undercut flathead screws are provided as a standard pack unless otherwise specified. Wood and thread-forming screws also available. Security screws optional at extra cost.

AVAILABLE ELECTRIC PREPS: EPT, ATW, EMS, CTW4, CTW5, CTW8, CTW10, CTW12, CMG, AP and RP.


SL44 HINGE SCREW COUNT

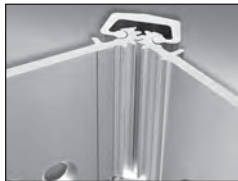
HINGE LENGTH & DUTY RATING	DOOR SCREWS	FRAME SCREWS
83" HD600	19	19
95" HD600	21	21

SELECT ADVANTAGES



PAIR-MATCHED™ HINGE LEAVES

Manufactured together, machined together and anodized together, making SELECT hinges fit your doors better and last longer. *An exclusive SELECT benefit.*



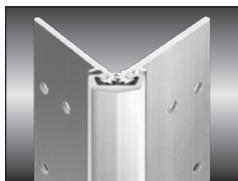
LIFETIME LUBRICATION

Eliminates the need for periodic maintenance. Quiet performance. Fights gear cap wear. *An exclusive SELECT benefit.*



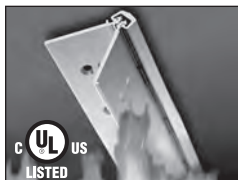
ANODIZED AFTER MACHINING

Delivers superior wear, durability and life. Inhibits corrosion. Few hinge makers follow SELECT's lead in using this superior manufacturing process.



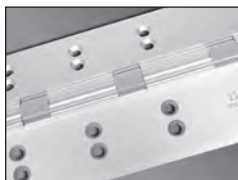
SUSTAINABLE

Made from up to 100% recycled aluminum. Reduces environmental impact and qualifies for LEED points. *An exclusive SELECT benefit.*



PATENTED 3-HR. FIRE RATING

Most SELECT hinges are fire rated for 90 minutes. 3-Hr. fire rating, optional at extra cost, approved for positive/negative pressure. No fire pins or studs required. Patented design innovation. *An exclusive SELECT benefit.*



CONSISTENT TEMPLATING

Hole pattern is identical on both Heavy Duty 300 and Heavy Duty 600 models, so SELECT hinges line up precisely for easier and faster installation. *An exclusive SELECT benefit.*



COATED FASTENERS

Provide additional corrosion protection with either self-drilling, thread-forming (SDTF) or thread-forming (TF) screws. *An exclusive SELECT benefit.*



CUSTOM COLORS

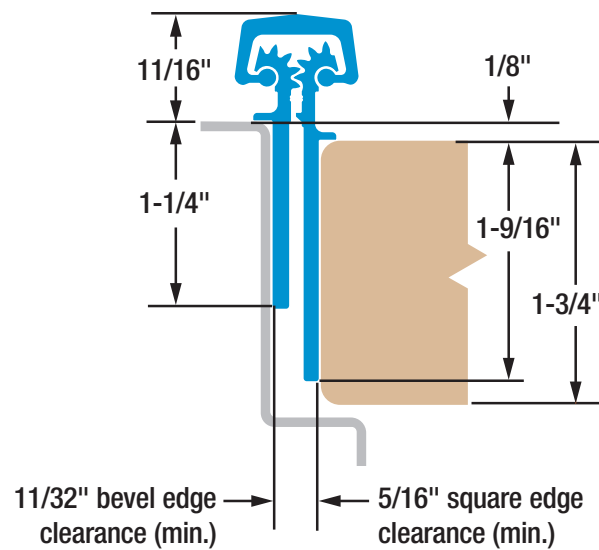
Match any paint color on the gear cap or the entire hinge and fasteners, including our always-in-stock Bone White gear caps. Anodized colors also available.

SELECT HINGE PERFORMANCE

- A SELECT geared continuous hinge has been tested in accordance with ANSI 250.4-1994 test procedure and acceptance criteria for physical endurance for steel doors and hardware and has surpassed 25,000,000 cycles during testing by an independent laboratory. On a door cycling 400,000 times per year, a SELECT hinge will be performing for over 62 years.
- SELECT geared continuous hinges are built to handle abuse from high-traffic applications. They are applied to the surface on the edge of the frame and door. No machining or reinforcement is required.
- The revolutionary SELECT geared continuous hinge puts an end to costly and irritating hinge failure problems, the most common cause of entrance failure.
- On conventional hinges, opening and “kick-back” energy concentrate on a few inches of fastened reinforcing plate — with the top hinge handling 100% of the force. Pinless SELECT hinges bond the door and frame into an integrated, sag-free unit. “Kick-back” energy dissipates along the entire length of the door and frame. (Compare this to a conventional hinge’s 4-1/2" to 5" at the top of the door and frame).
- SELECT geared continuous hinges eliminate the gap between the door and frame, providing a weatherproof, rust-proof, tamper-proof barrier. When the door is closed, there are no accessible screws, bolts or pins.
- SELECT SL44 geared continuous hinges are listed and tested by Underwriters Laboratories to meet the Positive and Negative pressure requirements of UL10B and UL10C, and are in accordance with UBC 7.2 (1997). SELECT SL44 geared continuous hinges are for use on swinging single fire doors (max. door opening of 4'x10') or pairs of fire doors (max. door opening of 8'x10'), including double egress, installed in masonry or drywall. SELECT SL44 geared continuous hinges are rated for up to 1-1/2 hours for wood composite and wood core type fire doors. A special patented process can be added to increase the fire rating to 3 hours (NO FIRE PINS OR STUDS REQUIRED) for hollow metal or steel covered composite type doors.



- Short frame leaf allows for removable stop applications
- 1/8" door inset
- For 1-3/4" doors



SL48 Concealed Geared Continuous Hinge



Tested to last six decades



Reduce maintenance costs and hassles. Independent lab tests on an FRP door prove

SELECT hinges withstand 25 million cycles — more than 60 years of high-traffic use. Pair-Matched™ hinge leaves, lifetime lubrication and anodizing after machining deliver the longest life of any continuous hinge.

Covered by the only Continuous Warranty



Because SELECT geared continuous hinges have proven themselves in independent testing, we offer the industry's only Continuous Warranty. It

covers any failure of our aluminum geared continuous hinges — with no expiration date — as long as they are properly installed. Durability and worry-free performance ... guaranteed in writing. *The warranty that never ends for the hinge that never quits.SM*

Certified by U.S. Department of State



After brutal testing, the State Department granted a SELECT geared continuous hinge its 60-minute certification — the department's highest level. The hinge deflected bullets in the Ballistic Resistance Test and withstood sledgehammers,

wedges and other tools in the Forced Entry Test. Approved for use in U.S. embassies overseas.

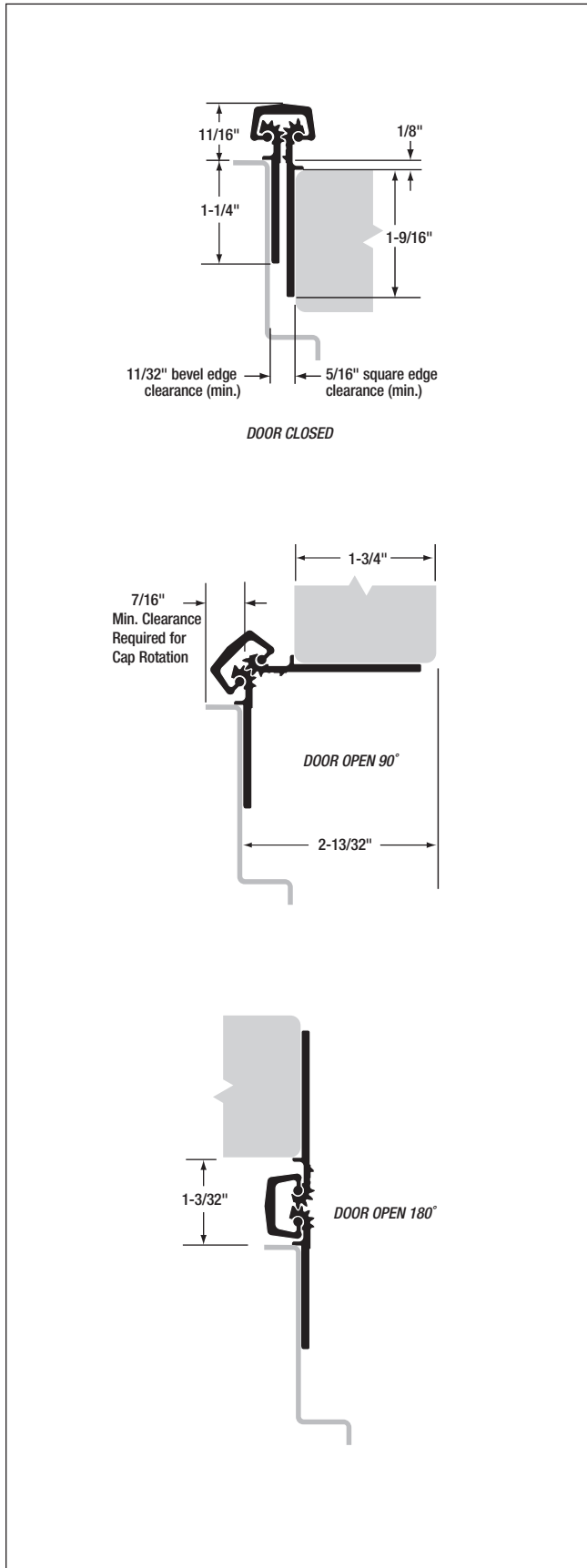
Geared to ship in 48 hours

Geared to ship in



SELECT ships hinges faster than anyone in the industry. 99.9% of our hinge orders ship in 48 hours; more than half are shipped in only 24 hours. Projects won't be delayed while waiting weeks for hinges.

NOTES:

SL48 Concealed Geared Continuous Hinge


MATERIAL: Extruded 6063 T6 aluminum alloy with self-lubricating polyester thrust bearings.

LENGTHS: 83" and 95" lengths standard for nominal door heights. Hinges can be cut to shorter lengths. Longer hinges are not available.

LOAD/FREQUENCY RATING: For 1-3/4" doors. 48" max. door width in 16 gauge hollow metal (min.) or 1/8" aluminum (min.).

Heavy Duty 600 — For high-frequency doors up to 600 lb. Rivnuts are recommended in the frame and door when the door exceeds 450 lb.

FINISHES: All SL48 hinges are stocked in Clear and Dark Bronze anodized aluminum. Custom anodized or painted finishes are available. Product painted or anodized in the field voids the SELECT hinge warranty.

CLOSERS: Conventional overhead surface, concealed sliding arm overhead or floor closers may be used with SELECT hinges. Pivot-type floor closers (with a fixed, conflicting center pivot) must be replaced.

ORDER: Specify length, finish and heavy duty 600 (HD600). Also, specify door and frame screw applications. 12-24 x 3/4" self-drilling, thread-forming 410SS Phillips undercut flathead screws are provided as a standard pack unless otherwise specified. Wood and thread-forming screws also available. Security screws optional at extra cost.

AVAILABLE ELECTRIC PREPS: EPT, ATW, EMS, CTW4, CTW5, CTW8, CTW10, CTW12, CMG, AP and RP.


SL48 HINGE SCREW COUNT

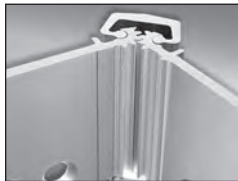
HINGE LENGTH & DUTY RATING	DOOR SCREWS	FRAME SCREWS
83" HD600	19	19
95" HD600	21	21

SELECT ADVANTAGES



PAIR-MATCHED™ HINGE LEAVES

Manufactured together, machined together and anodized together, making SELECT hinges fit your doors better and last longer. *An exclusive SELECT benefit.*



LIFETIME LUBRICATION

Eliminates the need for periodic maintenance. Quiet performance. Fights gear cap wear. *An exclusive SELECT benefit.*



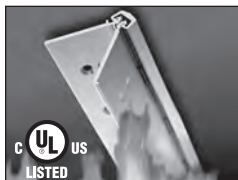
ANODIZED AFTER MACHINING

Delivers superior wear, durability and life. Inhibits corrosion. Few hinge makers follow SELECT's lead in using this superior manufacturing process.



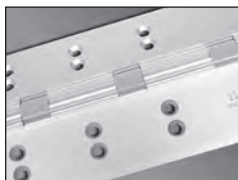
SUSTAINABLE

Made from up to 100% recycled aluminum. Reduces environmental impact and qualifies for LEED points. *An exclusive SELECT benefit.*



PATENTED 3-HR. FIRE RATING

Most SELECT hinges are fire rated for 90 minutes. 3-Hr. fire rating, optional at extra cost, approved for positive/negative pressure. No fire pins or studs required. Patented design innovation. *An exclusive SELECT benefit.*



CONSISTENT TEMPLATING

Hole pattern is identical on both Heavy Duty 300 and Heavy Duty 600 models, so SELECT hinges line up precisely for easier and faster installation. *An exclusive SELECT benefit.*



COATED FASTENERS

Provide additional corrosion protection with either self-drilling, thread-forming (SDTF) or thread-forming (TF) screws. *An exclusive SELECT benefit.*



CUSTOM COLORS

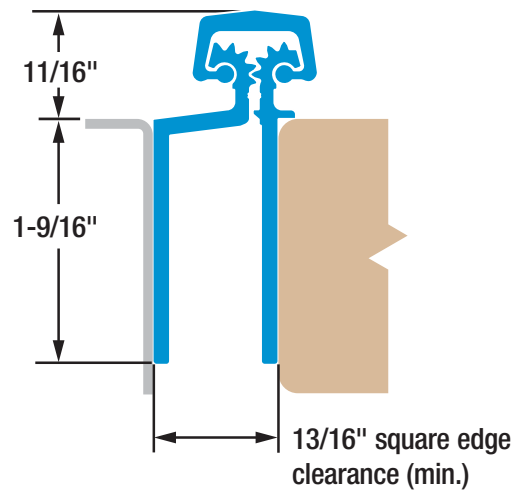
Match any paint color on the gear cap or the entire hinge and fasteners, including our always-in-stock Bone White gear caps. Anodized colors also available.

SELECT HINGE PERFORMANCE

- A SELECT geared continuous hinge has been tested in accordance with ANSI 250.4-1994 test procedure and acceptance criteria for physical endurance for steel doors and hardware and has surpassed 25,000,000 cycles during testing by an independent laboratory. On a door cycling 400,000 times per year, a SELECT hinge will be performing for over 62 years.
- SELECT geared continuous hinges are built to handle abuse from high-traffic applications. They are applied to the surface on the edge of the frame and door. No machining or reinforcement is required.
- The revolutionary SELECT geared continuous hinge puts an end to costly and irritating hinge failure problems, the most common cause of entrance failure.
- On conventional hinges, opening and “kick-back” energy concentrate on a few inches of fastened reinforcing plate — with the top hinge handling 100% of the force. Pinless SELECT hinges bond the door and frame into an integrated, sag-free unit. “Kick-back” energy dissipates along the entire length of the door and frame. (Compare this to a conventional hinge’s 4-1/2" to 5" at the top of the door and frame).
- SELECT geared continuous hinges eliminate the gap between the door and frame, providing a weatherproof, rust-proof, tamper-proof barrier. When the door is closed, there are no accessible screws, bolts or pins.
- SELECT SL48 geared continuous hinges are listed and tested by Underwriters Laboratories to meet the Positive and Negative pressure requirements of UL10B and UL10C, and are in accordance with UBC 7.2 (1997). SELECT SL48 geared continuous hinges are for use on swinging single fire doors (max. door opening of 4'x10') or pairs of fire doors (max. door opening of 8'x10'), including double egress, installed in masonry or drywall. SELECT SL48 geared continuous hinges are rated for up to 1-1/2 hours for wood composite and wood core type fire doors. A special patented process can be added to increase the fire rating to 3 hours (NO FIRE PINS OR STUDS REQUIRED) for hollow metal or steel covered composite type doors.



- Safety hinge (when used without frame stop)
- Provides clearance sufficient to avoid the pinching of fingers
- Flush mounted (no door inset)
- For 1-3/4" doors



SL71 Concealed Geared Continuous Hinge



Tested to last six decades



Reduce maintenance costs and hassles. Independent lab tests on an FRP door prove

SELECT hinges withstand 25 million cycles — more than 60 years of high-traffic use. Pair-Matched™ hinge leaves, lifetime lubrication and anodizing after machining deliver the longest life of any continuous hinge.

Covered by the only Continuous Warranty



Because SELECT geared continuous hinges have proven themselves in independent testing, we offer the industry's only Continuous Warranty. It

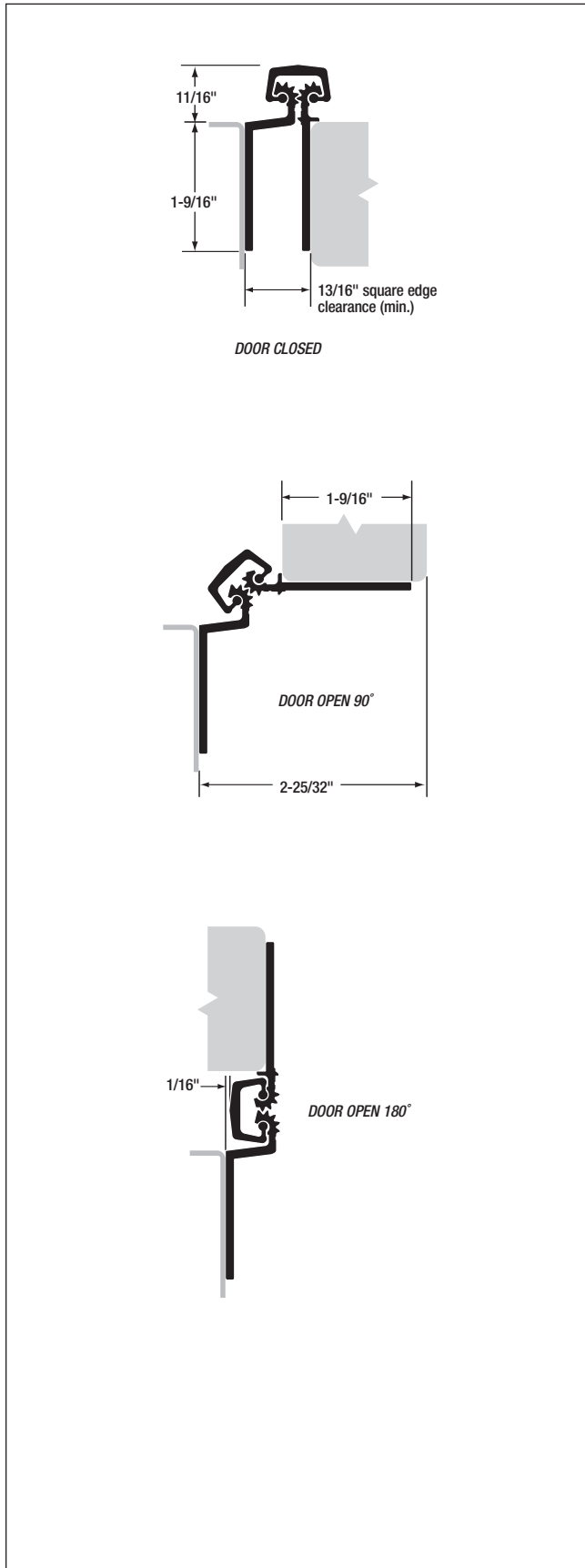
covers any failure of our aluminum geared continuous hinges — with no expiration date — as long as they are properly installed. Durability and worry-free performance ... guaranteed in writing. *The warranty that never ends for the hinge that never quits.*SM

Geared to ship in 48 hours



SELECT ships hinges faster than anyone in the industry. 99.9% of our hinge orders ship in 48 hours; more than half are shipped in only 24 hours. Projects won't be delayed while waiting weeks for hinges.

NOTES:

SL71 Concealed Geared Continuous Hinge


MATERIAL: Extruded 6063 T6 aluminum alloy with self-lubricating polyester thrust bearings.

LENGTHS: 83" and 95" lengths standard for nominal door heights. Hinges can be cut to shorter lengths. Longer hinges are not available.

LOAD/FREQUENCY RATING: For 1-3/4" doors. 48" max. door width in 16 gauge hollow metal (min.) or 1/8" aluminum (min.).

Heavy Duty 600 — For high-frequency doors up to 600 lb. Rivnuts are recommended in the frame and door when the door exceeds 450 lb.

FINISHES: All SL71 hinges are stocked in Clear and Dark Bronze anodized aluminum. Custom anodized or painted finishes are available. Product painted or anodized in the field voids the SELECT hinge warranty.

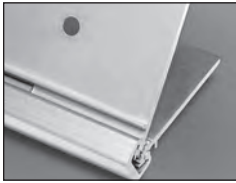
CLOSERS: Conventional overhead surface, concealed sliding arm overhead or floor closers may be used with SELECT hinges. Pivot-type floor closers (with a fixed, conflicting center pivot) must be replaced.

ORDER: Specify length, finish and heavy duty 600 (HD600). Also, specify door and frame screw applications. 12-24 x 3/4" self-drilling, thread-forming 410SS Phillips undercut flathead screws are provided as a standard pack unless otherwise specified. Wood and thread-forming screws also available. Security screws optional at extra cost.



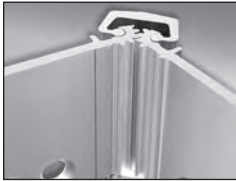
SL71 HINGE SCREW COUNT		
HINGE LENGTH & DUTY RATING	DOOR SCREWS	FRAME SCREWS
83" HD600	19	19
95" HD600	21	21

SELECT ADVANTAGES



PAIR-MATCHED™ HINGE LEAVES

Manufactured together, machined together and anodized together, making SELECT hinges fit your doors better and last longer.
An exclusive SELECT benefit.



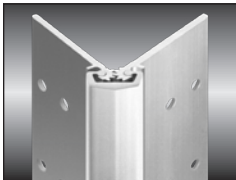
LIFETIME LUBRICATION

Eliminates the need for periodic maintenance. Quiet performance. Fights gear cap wear.
An exclusive SELECT benefit.



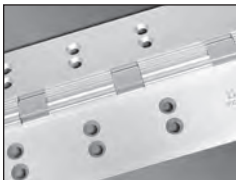
ANODIZED AFTER MACHINING

Delivers superior wear, durability and life. Inhibits corrosion. Few hinge makers follow SELECT's lead in using this superior manufacturing process.



SUSTAINABLE

Made from up to 100% recycled aluminum. Reduces environmental impact and qualifies for LEED points.
An exclusive SELECT benefit.



CONSISTENT TEMPLATING

Hole pattern is identical on both Heavy Duty 300 and Heavy Duty 600 models, so SELECT hinges line up precisely for easier and faster installation.
An exclusive SELECT benefit.



COATED FASTENERS

Provide additional corrosion protection with either self-drilling, thread-forming (SDTF) or thread-forming (TF) screws.
An exclusive SELECT benefit.

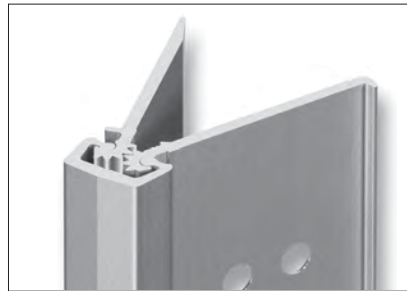


CUSTOM COLORS

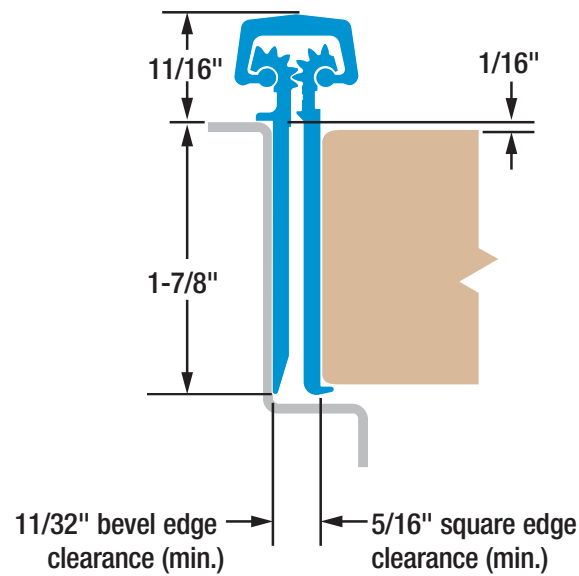
Match any paint color on the gear cap or the entire hinge and fasteners, including our always-in-stock Bone White gear caps. Anodized colors also available.

SELECT HINGE PERFORMANCE

- A SELECT geared continuous hinge has been tested in accordance with ANSI 250.4-1994 test procedure and acceptance criteria for physical endurance for steel doors and hardware and has surpassed 25,000,000 cycles during testing by an independent laboratory. On a door cycling 400,000 times per year, a SELECT hinge will be performing for over 62 years.
- SELECT geared continuous hinges are built to handle abuse from high-traffic applications. They are applied to the surface on the edge of the frame and door. No machining or reinforcement is required.
- The revolutionary SELECT geared continuous hinge puts an end to costly and irritating hinge failure problems, the most common cause of entrance failure.
- On conventional hinges, opening and “kick-back” energy concentrate on a few inches of fastened reinforcing plate — with the top hinge handling 100% of the force. Pinless SELECT hinges bond the door and frame into an integrated, sag-free unit. “Kick-back” energy dissipates along the entire length of the door and frame. (Compare this to a conventional hinge’s 4-1/2" to 5" at the top of the door and frame).
- SELECT geared continuous hinges eliminate the gap between the door and frame, providing a weatherproof, rust-proof, tamper-proof barrier. When the door is closed, there are no accessible screws, bolts or pins.



- Beveled frame leaf allows for weatherstripping or smoke seal
- Door edge protector
- 1/16" door inset
- For 1-3/4" doors



SL84

Concealed Geared Continuous Hinge



SL84

Tested to last six decades



Reduce maintenance costs and hassles. Independent lab tests on an FRP door prove

SELECT hinges withstand 25 million cycles — more than 60 years of high-traffic use. Pair-Matched™ hinge leaves, lifetime lubrication and anodizing after machining deliver the longest life of any continuous hinge.

Covered by the only Continuous Warranty



Because SELECT geared continuous hinges have proven themselves in independent testing, we offer the industry's only Continuous Warranty. It

covers any failure of our aluminum geared continuous hinges — with no expiration date — as long as they are properly installed. Durability and worry-free performance ... guaranteed in writing. *The warranty that never ends for the hinge that never quits.SM*

Certified by U.S. Department of State



After brutal testing, the State Department granted a SELECT geared continuous hinge its 60-minute certification — the department's highest level. The hinge deflected bullets in the Ballistic Resistance Test and withstood sledgehammers,

wedges and other tools in the Forced Entry Test. Approved for use in U.S. embassies overseas.

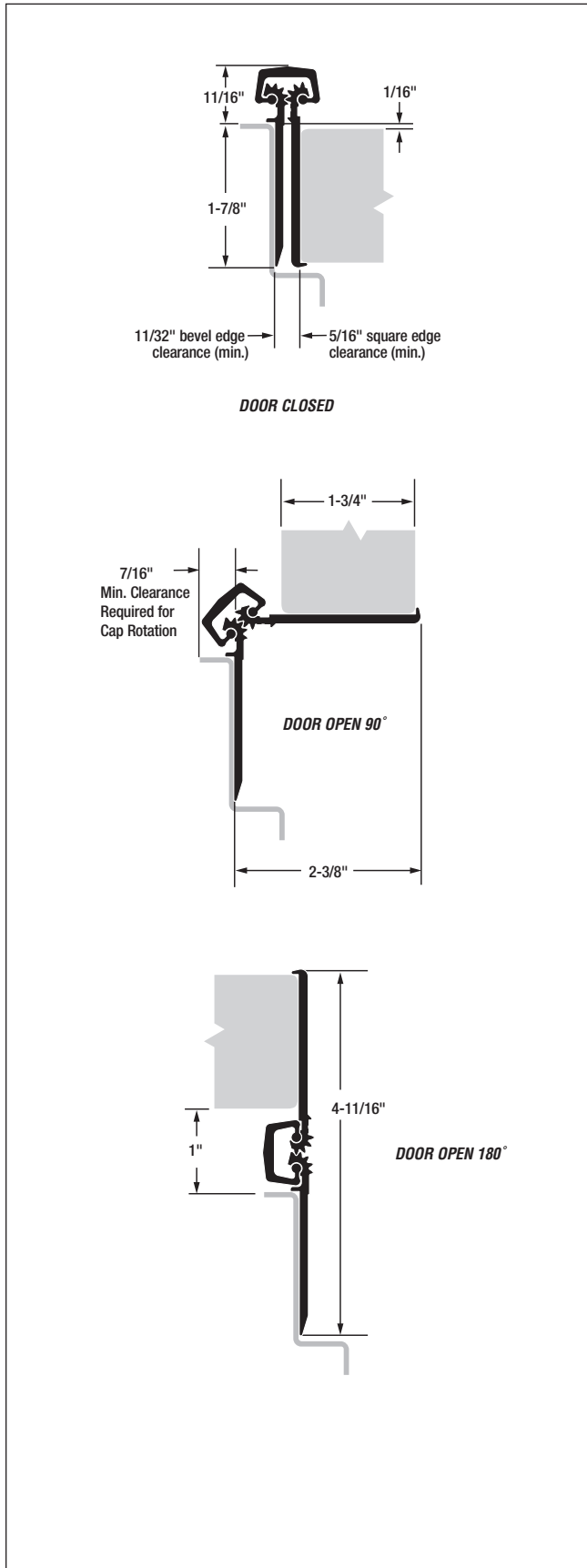
Geared to ship in 48 hours

Geared to ship in



SELECT ships hinges faster than anyone in the industry. 99.9% of our hinge orders ship in 48 hours; more than half are shipped in only 24 hours. Projects won't be delayed while waiting weeks for hinges.

NOTES:

SL84 Concealed Geared Continuous Hinge


MATERIAL: Extruded 6063 T6 aluminum alloy with self-lubricating polyester thrust bearings.

LENGTHS: 83" and 95" lengths standard for nominal door heights. Custom lengths are available.

LOAD/FREQUENCY RATINGS: For 1-3/4" doors. 48" max. door width in 16 gauge hollow metal (min.) or 1/8" aluminum (min.).

Heavy Duty 600 – For high-frequency doors up to 600 lb. Rivnuts are recommended in the frame and door when the door exceeds 450 lb.

Heavy Duty LL – Our heavy duty 600 with additional fastener holes for low- to medium-frequency doors up to 1,000 lb., including most lead-lined doors. Rivnuts are recommended in the frame and door on extremely tall, extremely heavy or extra-wide doors.

FINISHES: All SL84 hinges are stocked in Clear and Dark Bronze anodized aluminum. Custom anodized or painted finishes are available. Product painted or anodized in the field voids the SELECT hinge warranty.

CLOSERS: Conventional overhead surface, concealed sliding arm overhead or floor closers may be used with SELECT hinges. Pivot-type floor closers (with a fixed, conflicting center pivot) must be replaced.

ORDER: Specify length, finish and heavy duty 600 (HD600) or heavy duty 600 with additional fastener holes (LL). Also, specify door and frame screw applications. 12-24 x 3/4" self-drilling, thread-forming 410SS Phillips undercut flathead screws are provided as a standard pack unless otherwise specified. Wood and thread-forming screws also available. Security screws optional at extra cost.

AVAILABLE ELECTRIC PREPS: EPT, ATW, EMS, CTW4, CTW5, CTW8, CTW10, CTW12, CMG, AP and RP.



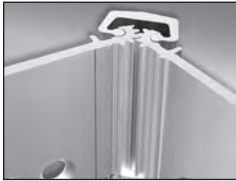
SL84 HINGE SCREW COUNT		
HINGE LENGTH & DUTY RATING	DOOR SCREWS	FRAME SCREWS
83" HD600	19	19
95" HD600	21	21
83" LL	26	26
95" LL	30	30

SELECT ADVANTAGES



PAIR-MATCHED™ HINGE LEAVES

Manufactured together, machined together and anodized together, making SELECT hinges fit your doors better and last longer. *An exclusive SELECT benefit.*



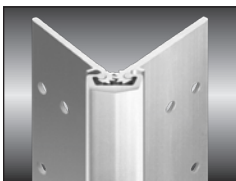
LIFETIME LUBRICATION

Eliminates the need for periodic maintenance. Quiet performance. Fights gear cap wear. *An exclusive SELECT benefit.*



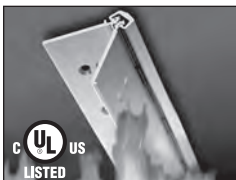
ANODIZED AFTER MACHINING

Delivers superior wear, durability and life. Inhibits corrosion. Few hinge makers follow SELECT's lead in using this superior manufacturing process.



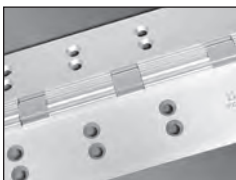
SUSTAINABLE

Made from up to 100% recycled aluminum. Reduces environmental impact and qualifies for LEED points. *An exclusive SELECT benefit.*



PATENTED 3-HR. FIRE RATING

Most SELECT hinges are fire rated for 90 minutes. 3-Hr. fire rating, optional at extra cost, approved for positive/negative pressure. No fire pins or studs required. Patented design innovation. *An exclusive SELECT benefit.*



CONSISTENT TEMPLATING

Hole pattern is identical on both Heavy Duty 300 and Heavy Duty 600 models, so SELECT hinges line up precisely for easier and faster installation. *An exclusive SELECT benefit.*



COATED FASTENERS

Provide additional corrosion protection with either self-drilling, thread-forming (SDTF) or thread-forming (TF) screws. *An exclusive SELECT benefit.*



CUSTOM COLORS

Match any paint color on the gear cap or the entire hinge and fasteners, including our always-in-stock Bone White gear caps. Anodized colors also available.

SELECT HINGE PERFORMANCE

- A SELECT geared continuous hinge has been tested in accordance with ANSI 250.4-1994 test procedure and acceptance criteria for physical endurance for steel doors and hardware and has surpassed 25,000,000 cycles during testing by an independent laboratory. On a door cycling 400,000 times per year, a SELECT hinge will be performing for over 62 years.
- SELECT geared continuous hinges are built to handle abuse from high-traffic applications. They are applied to the surface on the edge of the frame and door. No machining or reinforcement is required.
- The revolutionary SELECT geared continuous hinge puts an end to costly and irritating hinge failure problems, the most common cause of entrance failure.
- On conventional hinges, opening and “kick-back” energy concentrate on a few inches of fastened reinforcing plate — with the top hinge handling 100% of the force. Pinless SELECT hinges bond the door and frame into an integrated, sag-free unit. “Kick-back” energy dissipates along the entire length of the door and frame. (Compare this to a conventional hinge’s 4-1/2" to 5" at the top of the door and frame).
- SELECT geared continuous hinges eliminate the gap between the door and frame, providing a weatherproof, rust-proof, tamper-proof barrier. When the door is closed, there are no accessible screws, bolts or pins.
- SELECT SL84 geared continuous hinges are listed and tested by Underwriters Laboratories to meet the Positive and Negative pressure requirements of UL10B and UL10C, and are in accordance with UBC 7.2 (1997). SELECT SL84 geared continuous hinges are for use on swinging single fire doors (max. door opening of 4'x10') or pairs of fire doors (max. door opening of 8'x10'), including double egress, installed in masonry or drywall. SELECT SL84 geared continuous hinges are rated for up to 1-1/2 hours for wood composite and wood core type fire doors. A special patented process can be added to increase the fire rating to 3 hours (NO FIRE PINS OR STUDS REQUIRED) for hollow metal or steel covered composite type doors.

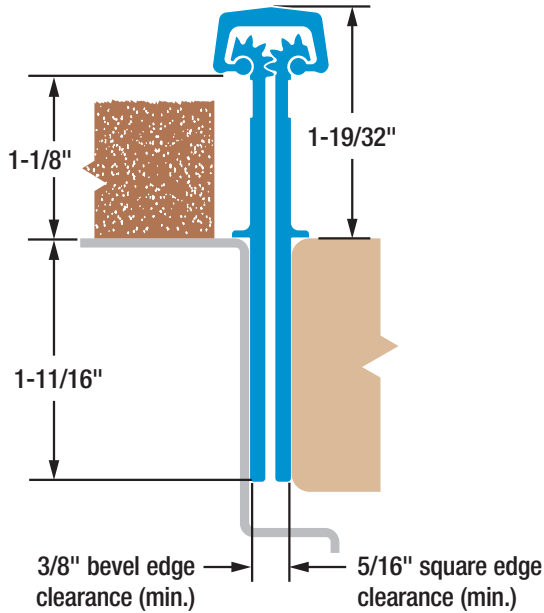


SELECT HINGES®

WIDE THROW • SWING CLEAR GEARED HINGES

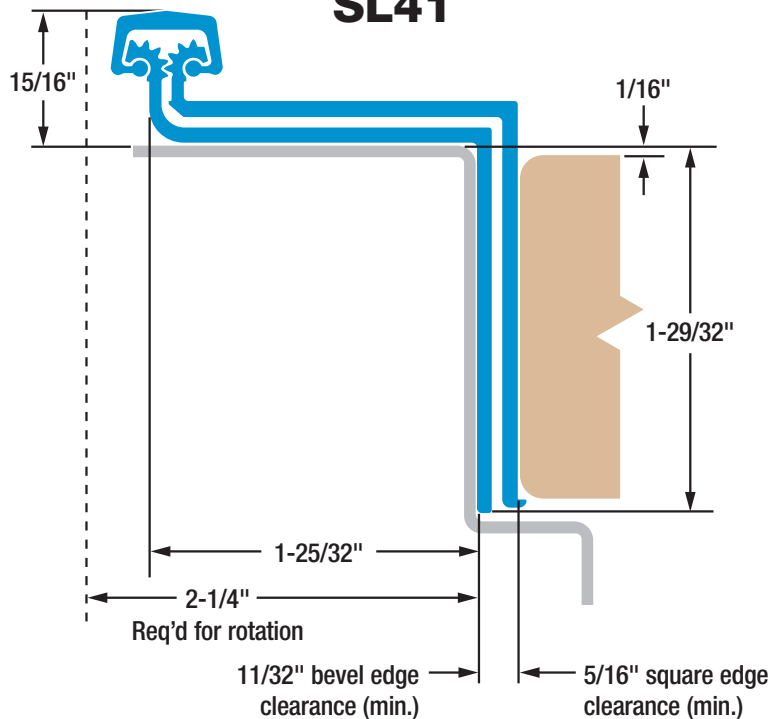
Wide Throw

SL40



Swing Clear

SL41



WIDE THROW • SWING CLEAR

WIDE THROW • SWING CLEAR GEARED HINGES



PART NUMBER INTERCHANGE: WIDE THROW • SWING CLEAR

SELECT MODELS	NGP	ROTON	PEMKO	STANLEY	ABH	PBB	IVES
SL40 HD600		780-235HD	WTFMHD	661HDWT	A110WT		040XY
SL41 HD600	HD4100	780-041HD	OFSM	674HD	A410HD	CG31C	
SL41 LL	HD4100-LL	780-041LL			A410LL		

* Not equivalent hinge but possible SELECT hinge substitution depending on application.

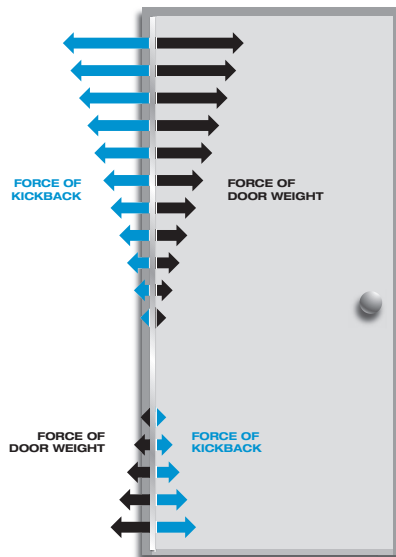
** Compatible with inset & profile.

No equivalent hinge available from this manufacturer.

HINGE STRESS COMPARISON

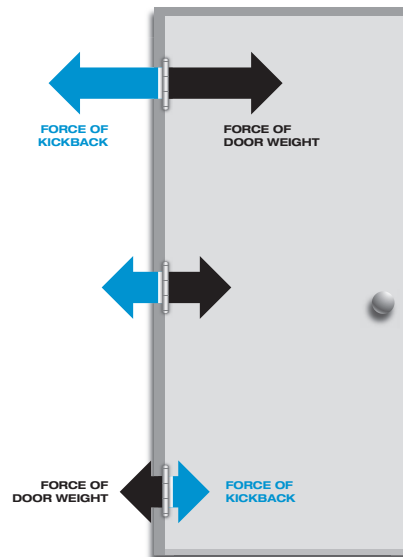
CONTINUOUS HINGES

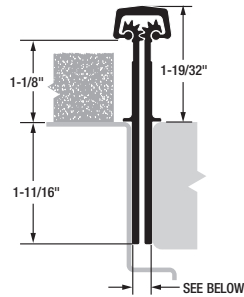
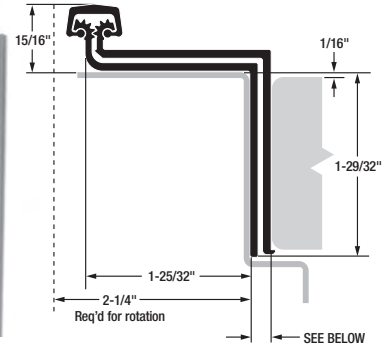
SELECT continuous hinges unite the door and frame into an integrated, sag-free unit. "Kickback" energy dissipates along the entire length of the door and frame and prevents hinge failure.



CONVENTIONAL BUTT HINGES

On conventional hinges, opening and "kickback" energy from closers and automatic operators concentrates on the top butt hinge. This force works against the top hinge, eventually forcing it apart or pulling it from the frame/door.



SL40 WIDE THROW

SL41 SWING CLEAR


Door Clearances

For Square and Beveled-Edge Doors

IMPORTANT: All uncut SL40 and SL41 hinges are non-handed and templated. Model SL40 remains non-handed after cutting. Model SL41 becomes handed after cutting.

* **NOTE:** Refer to NFPA 80 manual for clearance requirements on fire-rated entrances.

Important Warranty Information:

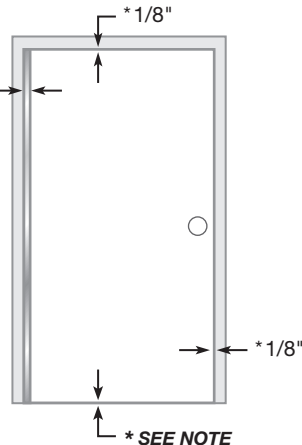
The following actions will void any warranty, expressed or implied:

- Failure to install the hinge according to manufacturer's specifications and requirements. (For more information, visit selecthingerequirements.com.)
- Use of fasteners other than those supplied with the hinge.
- Unauthorized field modifications, including alteration or removal of the factory-applied lubricant, altering the original finish or painting the hinge.

Single Door

Hinge side clearance

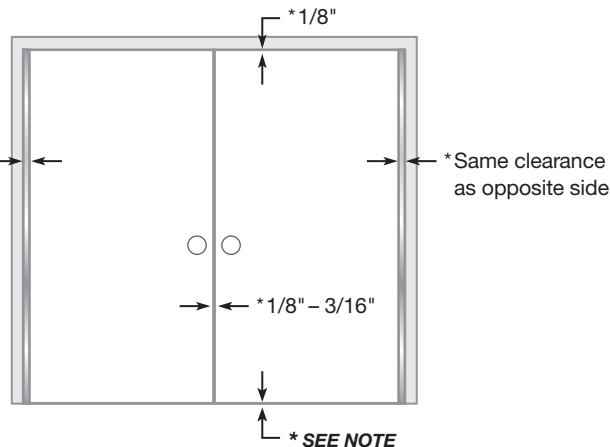
SL40 & SL41 Square Edge	* 5/16"
SL40 Beveled Edge	* 3/8"
SL41 Beveled Edge	* 11/32"



Double Doors (Pair)

Hinge side clearance

SL40 & SL41 Square Edge	* 5/16"
SL40 Beveled Edge	* 3/8"
SL41 Beveled Edge	* 11/32"



Tools Needed

- Metal-cutting saw
- Tape measure
- #13 or 3/16" drill bit
- 5/32" drill bit (wood frames/doors)
- #3 Phillips drive
- Shims

Parts Supplied

- #12-24 self-drilling, thread-forming (SDTF) 410 SS Phillips undercut flathead screws

Optional Parts

- #12 410 SS Phillips undercut flathead wood screws
- #12-24 thread-forming (TF) 410 SS Phillips undercut flathead screws
- Protective gloves are recommended

How to Cut the Hinge to Fit

- A. Keep hinge in "door closed" position (Fig. 1).
- B. Determine whether this will be a right-hand or left-hand installation.

IMPORTANT: Cut only one end of hinge. Cut end will be installed at the bottom.

Keep original templated six-hole pattern at top end of hinge.

NOTE: SL40 is non-handed and remains non-handed after cutting.

- C. Using a metal-cutting saw, begin the cut through the gear cap first.

NOTE: DO NOT cut through a set screw bearing.

- D. Reinstall any set screw bearing that may have been cut off.

A. Prepare Frame

1. Shim hinge to 1/8" below the header to allow for door clearance.
2. Hold hinge in "door open" position (Fig. 2), making sure frame leaf alignment flange (SL40) or frame face portion of the frame leaf (SL41) is tight against frame face.

3. Mark (or centerpunch) hole locations.

NOTE: TF screws and wood screws require pilot holes at marked locations. SDTF screws do not require pilot holes.

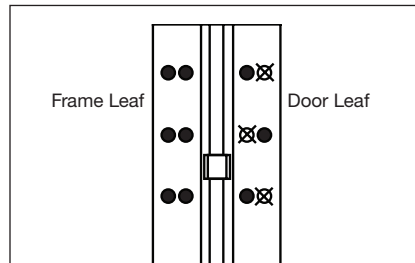
4. If using SDTF screws, go to Step 5. If using TF or wood screws, drill holes at marked locations. DO NOT attach hinge to the frame at this time.
 - Metal frame: Use #13 (.185") bit or 3/16" (.188") bit
 - Wood frame: Use 5/32" (.156") bit

B. Attach Door to Hinge

5. Align the door leaf alignment flange or the door leaf lip along the full length of the door edge (even if the door is slightly warped).

IMPORTANT: Top end of the hinge must be flush with the top of the door.

IMPORTANT: If installing hinge on a 90-minute fire-rated wood door, mark or centerpunch only one hole in each pair of holes at the top and bottom of the door leaf. DO NOT install the remaining screws in six-hole pattern on the door leaf. See illustration below.



6. Mark (or centerpunch) holes. If using SDTF screws, go to Step 7. If using TF or wood screws, drill holes at marked locations.
 - Metal door: Use #13 (.185") bit or 3/16" (.188") bit
 - Wood door: Use 5/32" (.156") bit
7. Fasten door leaf to door using #3 Phillips drive and fasteners provided.

C. Attach Door to Frame

8. Position door at 90 degrees to the frame. Shim door to the proper height so the door aligns with the top screw holes.
9. Install two screws at the top of hinge. Remove shim and align remaining holes. Install screws in middle and bottom two holes.
10. Check door for proper swing and clearance before installing remaining screws.

Reinforcing & Rivnuts®

No hinge reinforcement is necessary except on extremely high-frequency, extremely tall, extremely heavy or extra-wide doors. Rivnuts are recommended for use in the frame and door when the door exceeds 450 lb.

NOTE: Only SELECT steel Rivnuts are to be used with fire-rated SELECT hinges.

Grouted/Slushed-in Frames

For ease of installation, it is recommended some sort of mudguard be installed behind the frame. Do not use self-drilling, thread-forming (SDTF) screws to drill into grouted frames. If mudguards have not been used, carefully drill pilot holes through frame and remove grout for screw clearance. Do not oversize holes in frame.

Fire-Rated Hinges

All SELECT hinges (except SL71, SL77 and Toilet Partition hinges) are 90-minute UL-rated, without fire pins or studs. Please contact SELECT for complete information about its fire-rated hinges.



Fig. 1 Door Closed Position

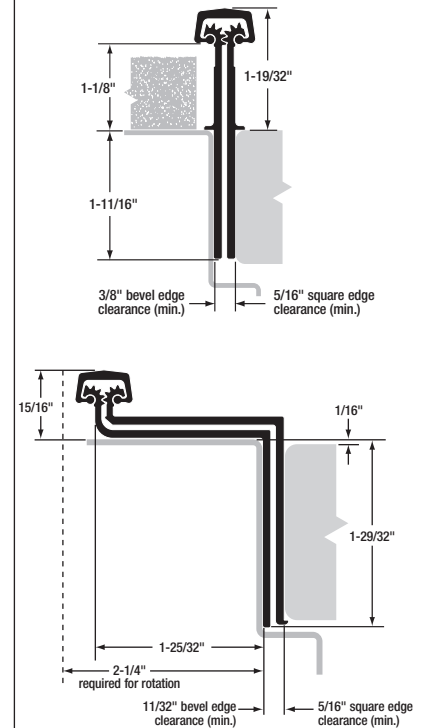
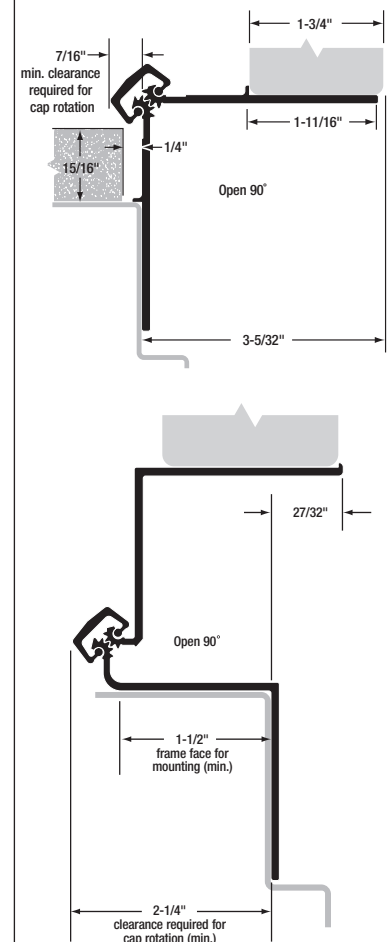
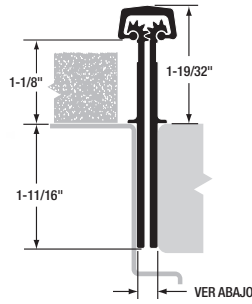
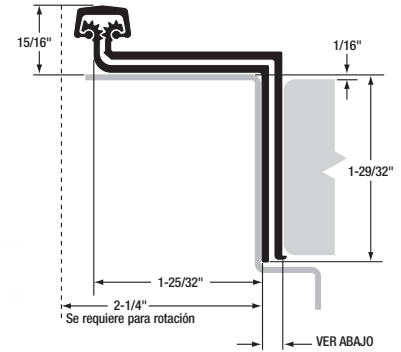


Fig. 2 Door Open 90°



SL40 LANZADO ANCHO

SL41 GIRO LIBRE

Espacios libres de puerta
Para puertas de borde cuadrado y de borde biselado

IMPORTANTE: IMPORTANTE: Todas las bisagras SL40 y SL41 sin cortar son invertibles y con plantilla. El modelo SL40 se mantiene invertible después del corte. El modelo SL41 se vuelve no invertible después del corte.

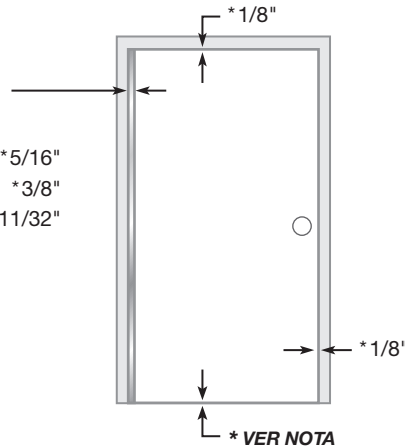
* **NOTA:** Consulte el manual de NFPA 80 para ver los requisitos de espacio libre en las entradas con clasificación ignífuga.

Información importante sobre la garantía:

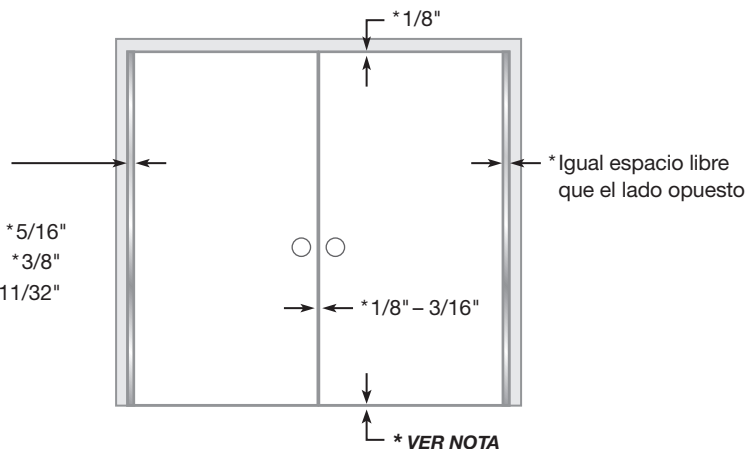
- Las acciones siguientes invalidarán cualquier garantía, ya sea explícita o implícita:
- No instalar la bisagra siguiendo las especificaciones y requisitos del fabricante. (Visite selecthingerequirements.com para obtener más información)
- Usar sujetadores que no sean los que se suministran con la bisagra.
- Modificaciones de terreno no autorizadas, como alterar o retirar el lubricante aplicado en la fábrica, alterar el acabado original o pintar la bisagra.

Puerta simple
Espacio libre en lado de bisagra

- | | |
|----------------------------|----------|
| SL40 y SL41 Borde cuadrado | * 5/16" |
| SL40 Borde biselado | * 3/8" |
| SL41 Borde biselado | * 11/32" |


Puertas dobles (par)
Espacio libre en lado de bisagra

- | | |
|----------------------------|----------|
| SL40 y SL41 Borde cuadrado | * 5/16" |
| SL40 Borde biselado | * 3/8" |
| SL41 Borde biselado | * 11/32" |



Herramientas necesarias

- Sierra para cortar metal
- Cinta para medir
- Broca N° 13 o de 3/16"
- Broca de 5/32" (marcos/puertas de madera)
- Destornillador Phillips N° 3
- Cuñas

Piezas suministradas

- 24 tornillos roscadores autorroscantes (SDTF) de cabeza plana Phillips sesgada N° 12 de acero inoxidable 410

Piezas opcionales

- Tornillos de cabeza plana sesgada para madera Phillips N° 12 de acero inoxidable 410
- 24 tornillos roscadores (TF) de cabeza plana Phillips sesgada N° 12 de acero inoxidable 410
- Se recomienda el uso de guantes protectores

Cómo cortar la charnela para que quepa

- A. Mantenga la charnela en la posición de "puerta cerrada" (Fig. 1).
- B. Determine si esta será una instalación para diestros o zurdos.

IMPORTANTE: Corte solamente un extremo de la charnela. El extremo cortado se instalará en la parte inferior. Guarde el patrón de templado original de seis orificios en el extremo superior de la charnela.

NOTA: SL40 es para diestros o zurdos y permanece así después de ser cortada.

- C. Usando una sierra para cortar metal, comience el corte primero por la tapa del engranaje.

NOTA: NO corte por el rodamiento del tornillo de ajuste.

- D. Vuelva a colocar cualquier rodamiento del tornillo de ajuste que hubiera podido cortarse.

A. Preparación del marco

1. Use cuñas para ubicar la charnela a 1/8" debajo del travesaño para permitir tolerancia para la puerta.
2. Sostenga la charnela en la posición de "puerta abierta" (Figura 2), asegurándose de que el reborde de alineación de la hoja del marco (SL40) o la porción de la cara del marco de la hoja del marco (SL41) esté apretado contra la cara del marco.

3. Marque (o punce) las ubicaciones de los orificios.

NOTA: Los tornillos roscadores (TF) y para madera necesitan orificios piloto en las ubicaciones marcadas. Los tornillos roscadores autorroscantes (SDTF) no necesitan orificios piloto.

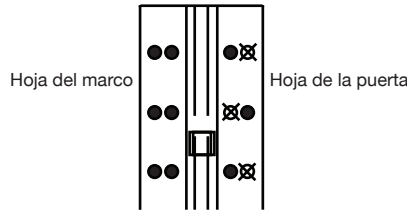
4. Si va a usar tornillos SDTF, vaya al paso 5. Si va a usar tornillos roscadores (TF) o para madera, taladre orificios en los lugares marcados. NO fije aún la charnela al marco.
 - Marco de metal: Use una broca N° 13 (0,185") o de 3/16" (0,188")
 - Marco de madera: Use una broca de 5/32" (0,156")

B. Fije la puerta a la charnela

5. Alinee el reborde de alineación de la hoja de la puerta o el labio de la hoja de la puerta a lo largo de la longitud total del borde de la puerta (aún si la puerta está ligeramente combada).

IMPORTANTE: El extremo superior de la charnela debe estar alineado con la parte superior de la puerta.

IMPORTANTE: Si va a instalar la charnela sobre una puerta de madera clasificada como resistente al fuego por 90 minutos, marque o perforo un solo orificio en cada par de orificios que estén en la parte superior e inferior de la hoja de la puerta. NO instale los tornillos restantes en los patrones de seis orificios en la hoja de la puerta. Vea la ilustración abajo.



6. Marque (o punce) los orificios. Si va a usar tornillos roscadores autorroscantes (SDTF), vaya al paso 7. Si va a usar tornillos roscadores (TF) o para madera, taladre orificios en los lugares marcados.

- Puerta de metal: Use una broca N° 13 (0,185") o de 3/16" (0,188")
- Puerta de madera: Use una broca de 5/32" (0,156")

7. Sujete la hoja de la puerta a la puerta usando un destornillador Phillips N° 3 y los sujetadores provistos.

C. Sujete la puerta al marco

8. Coloque la puerta a 90 grados respecto al marco. Coloque una cuña en la puerta a la altura apropiada de manera que la puerta se alinee con los orificios superiores de los tornillos.
9. Instale dos tornillos en la parte superior de la charnela. Quite la cuña y alinee los orificios restantes. Introduzca los tornillos en los orificios del medio y los dos de la parte inferior.
10. Verifique que la puerta gire y tenga la tolerancia adecuada antes de instalar los tornillos restantes.

Refuerzo y remaches Rivnuts®

No es necesario reforzar la bisagra excepto en puertas de uso extremadamente frecuente, extremadamente altas, extremadamente pesadas o extra anchas. Se recomienda el uso de remaches Rivnuts en el marco y la puerta cuando la puerta exceda las 450 lb.

NOTA: Solamente deben usarse remaches Rivnuts de acero SELECT con charnelas SELECT, clasificadas como resistentes al fuego.

Marcos empotrados en cemento

Para facilitar la instalación, se recomienda instalar algún tipo de salpicadera detrás del marco. No use tornillos roscadores autorroscantes (SDTF) para taladrar en los marcos de cemento. Si no se han usado salpicaderas, taladre cuidadosamente orificios que sirvan como guía a través del marco y quite el cemento para poder colocar el tornillo. No agrande los orificios del marco.

Charnelas clasificadas como resistentes al fuego

Todas las bisagras SELECT (excepto SL71, SL77 y bisagras para particiones de inodoros) tienen una clasificación UL de 90 minutos, sin pasadores o espárragos contra incendios. Por favor contacte a SELECT para obtener información completa acerca de las charnelas clasificadas como resistentes al fuego.



Fig. 1 Posición de puerta cerrada

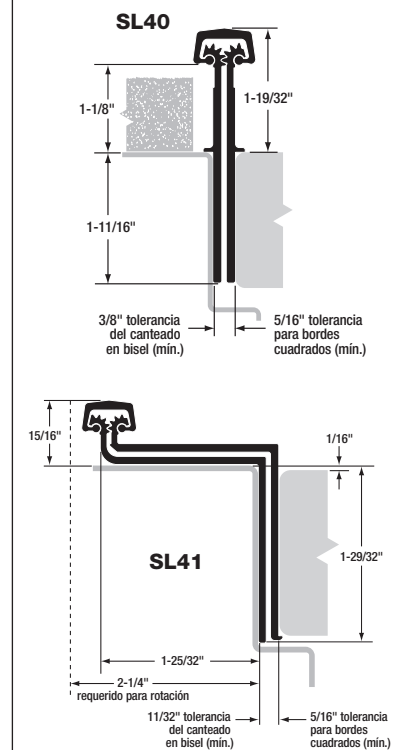
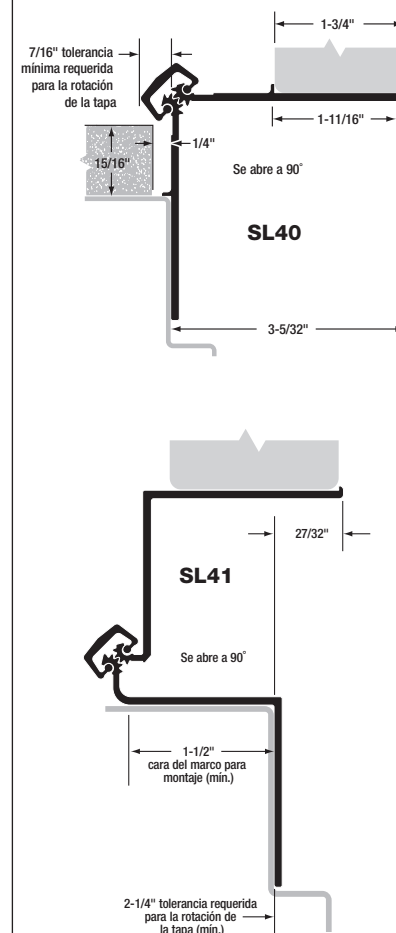
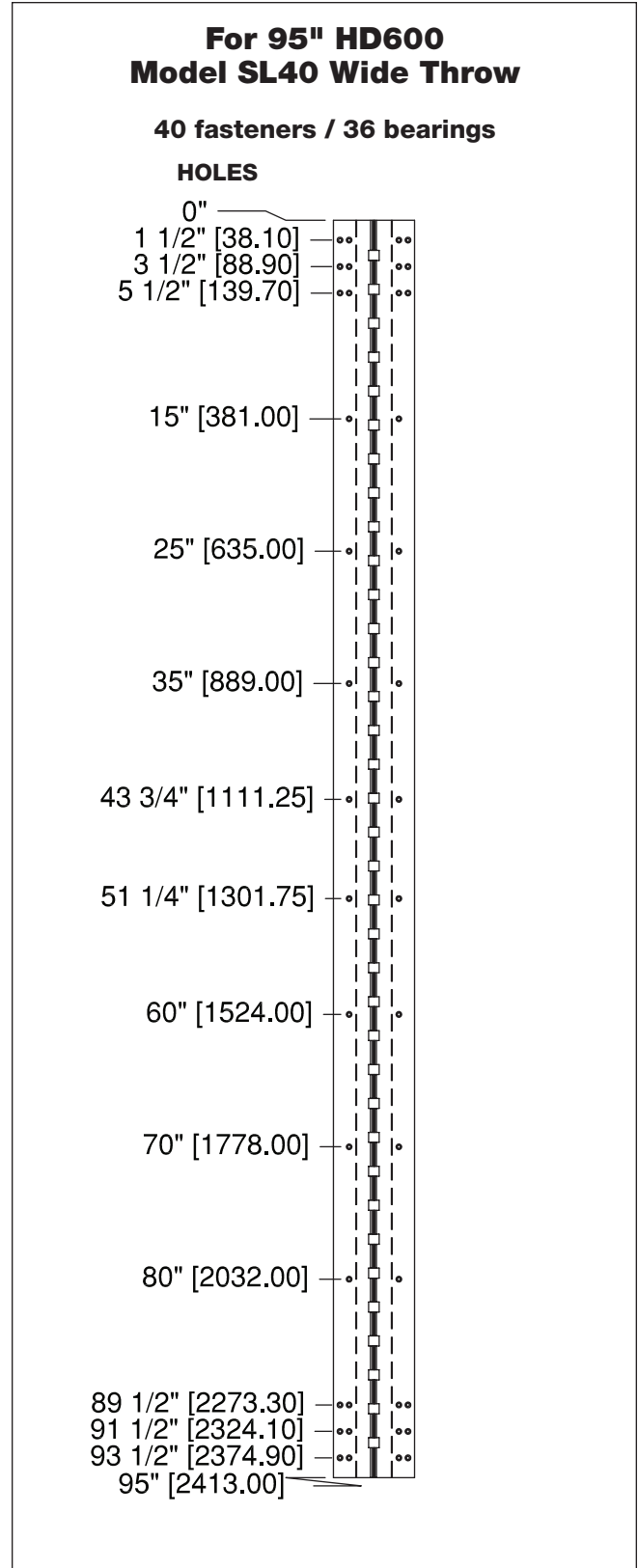
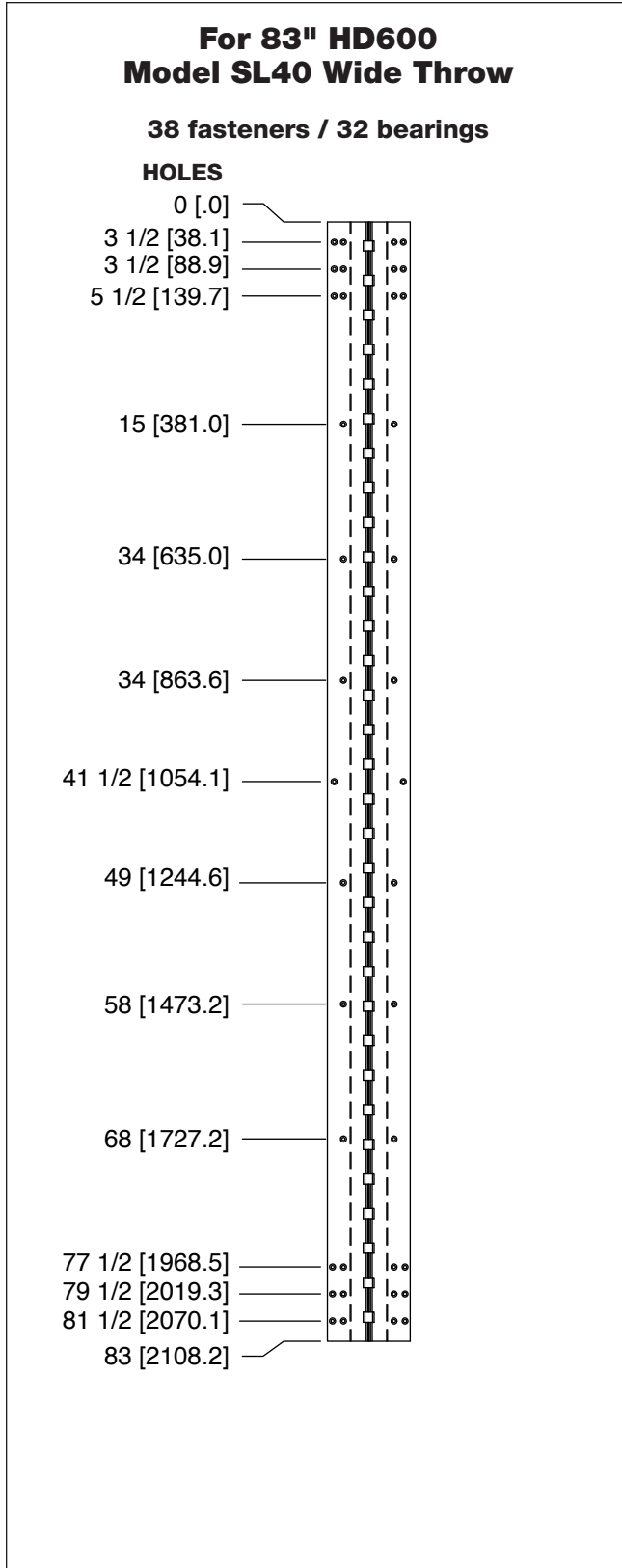


Fig. 2 Puerta abierta a 90°



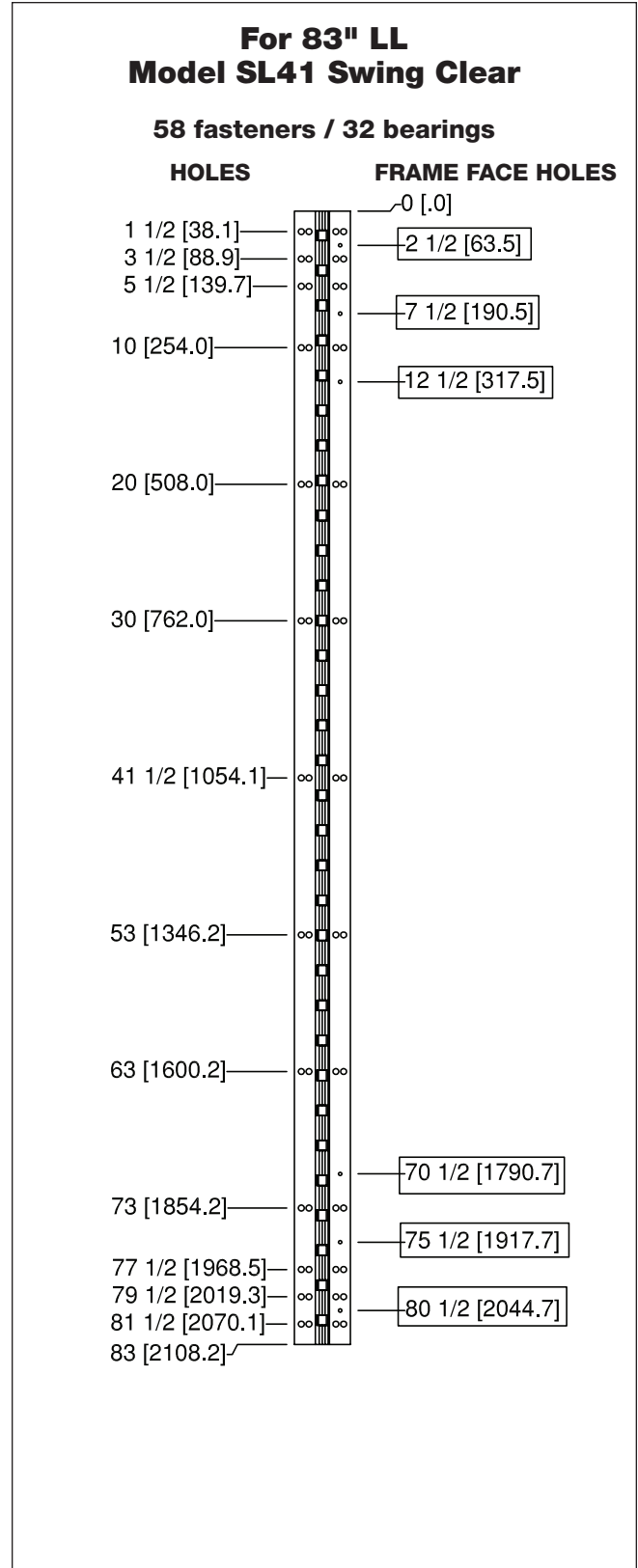
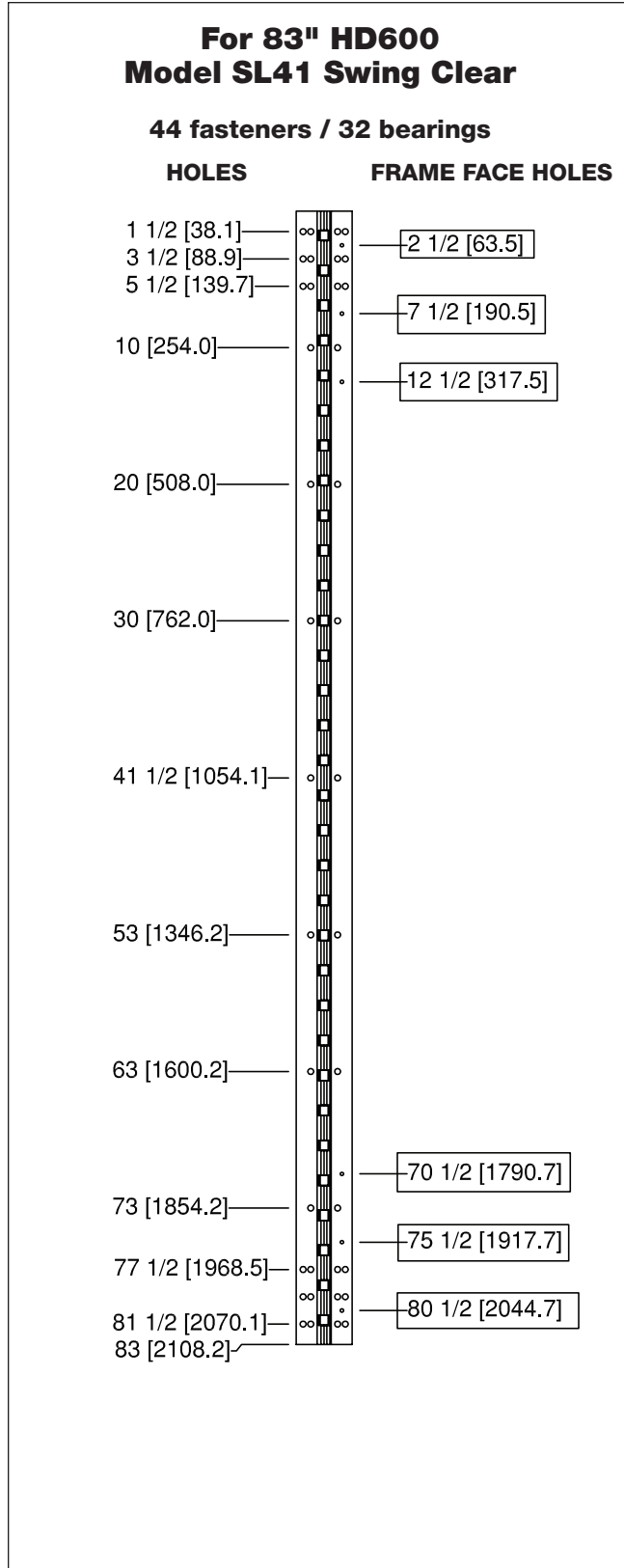
Wide Throw Geared Hinges

■ All dimensions are measured in inches and [millimeters] from the top of the door to the centerline of the holes.

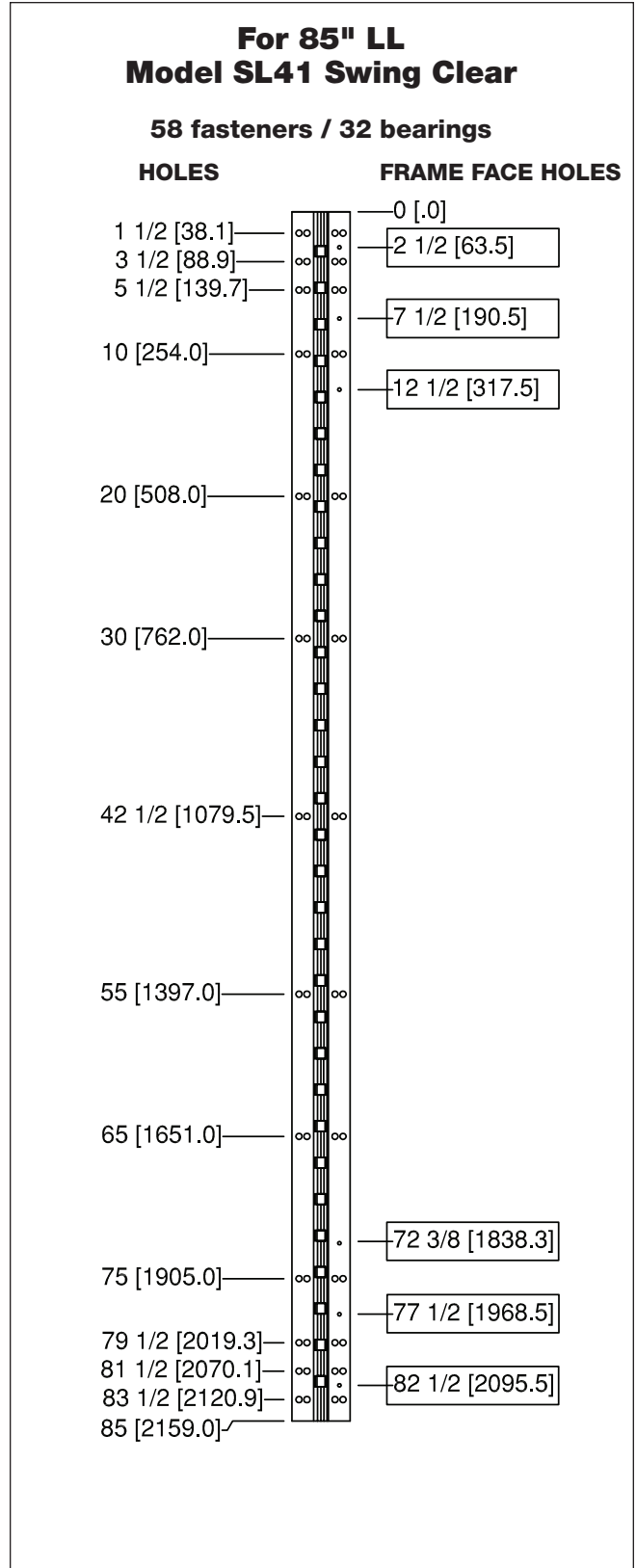
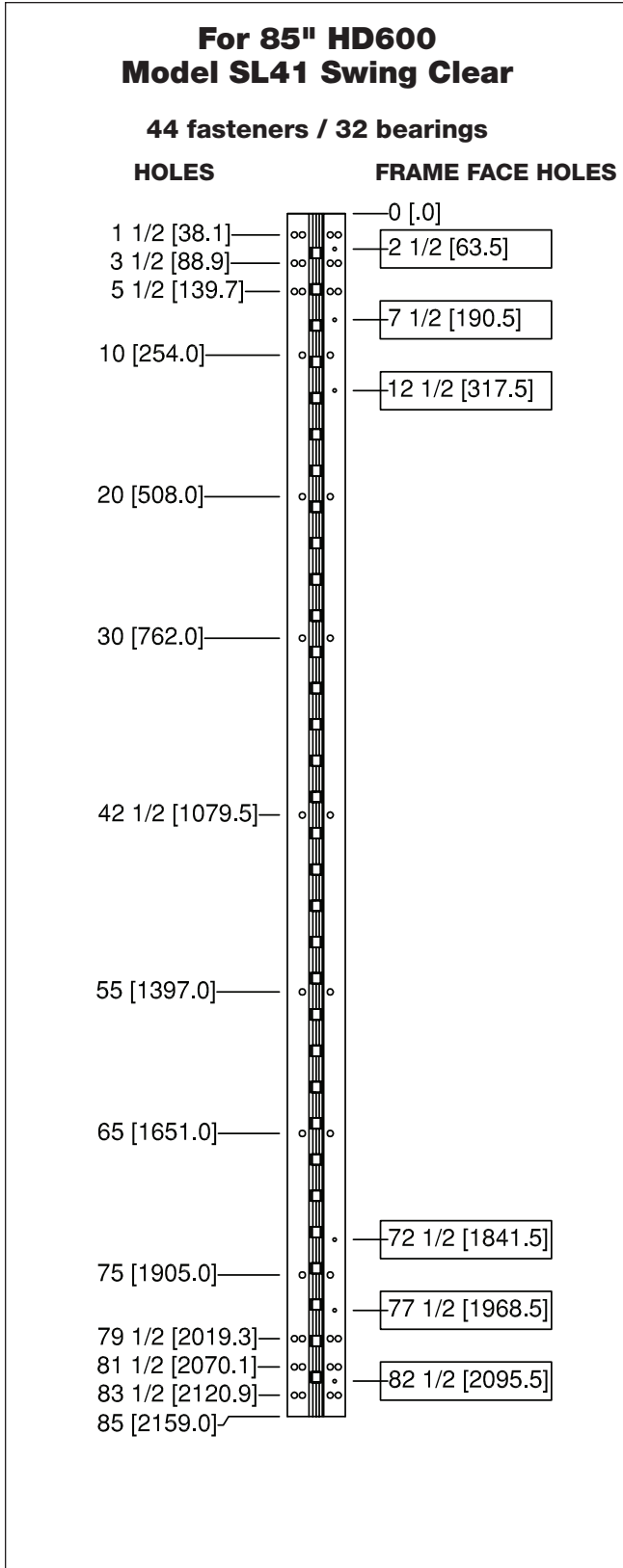


Swing Clear Geared Hinges

- All dimensions are measured in inches and [millimeters] from the top of the door to the centerline of the holes.
- Dimensions shown inside boxes are frame face mounting screw holes.

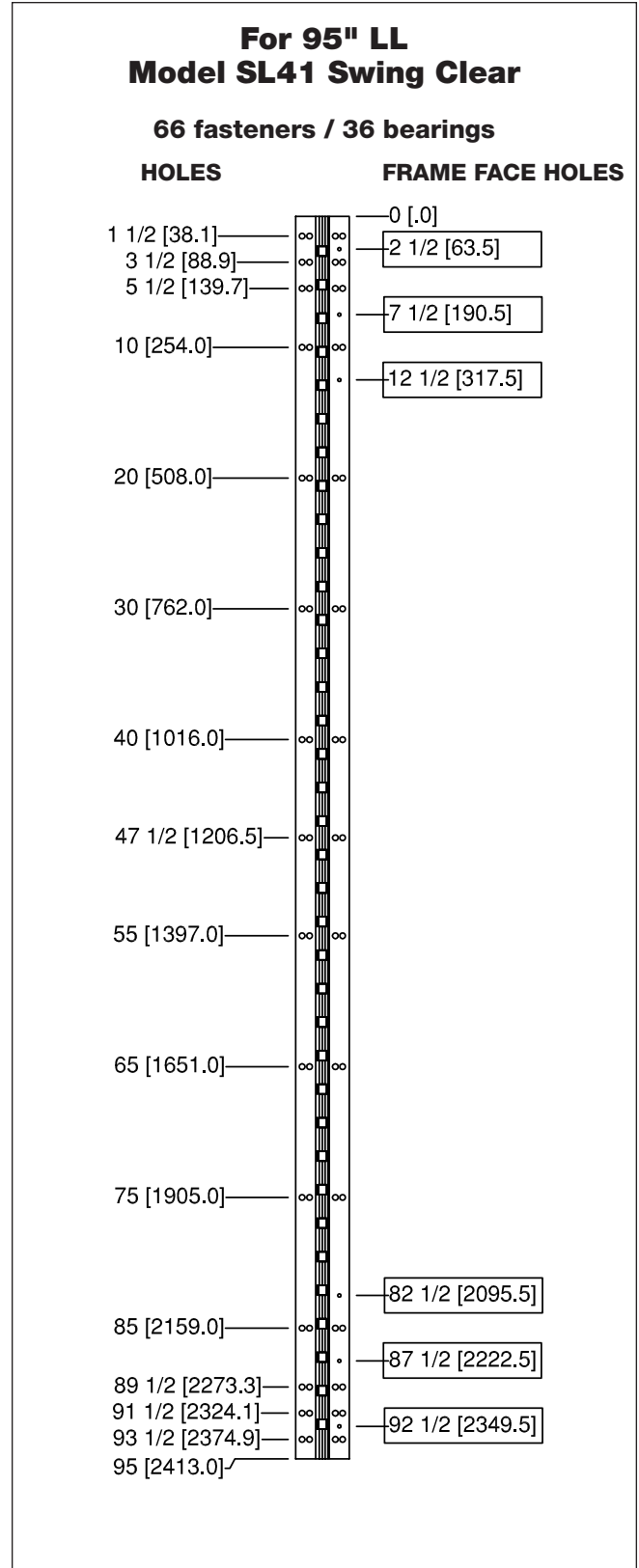
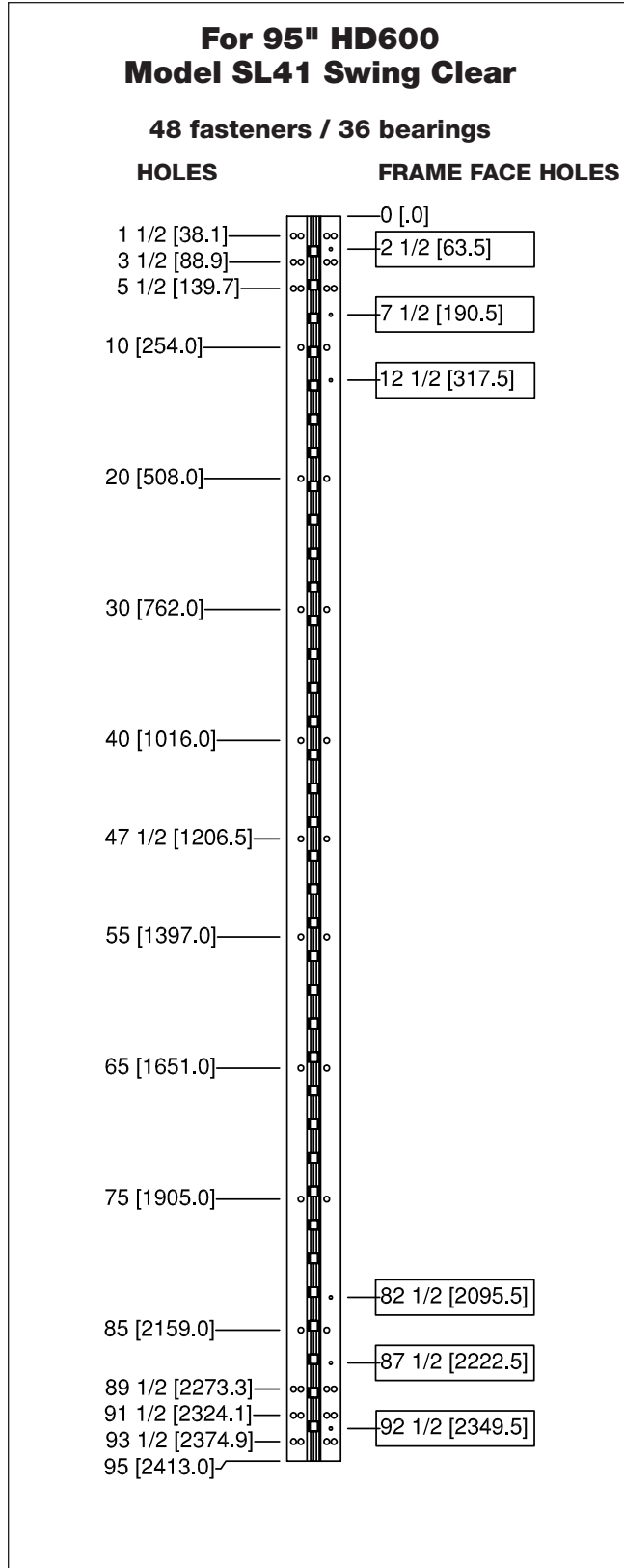


- All dimensions are measured in inches and [millimeters] from the top of the door to the centerline of the holes.
- Dimensions shown inside boxes are frame face mounting screw holes.

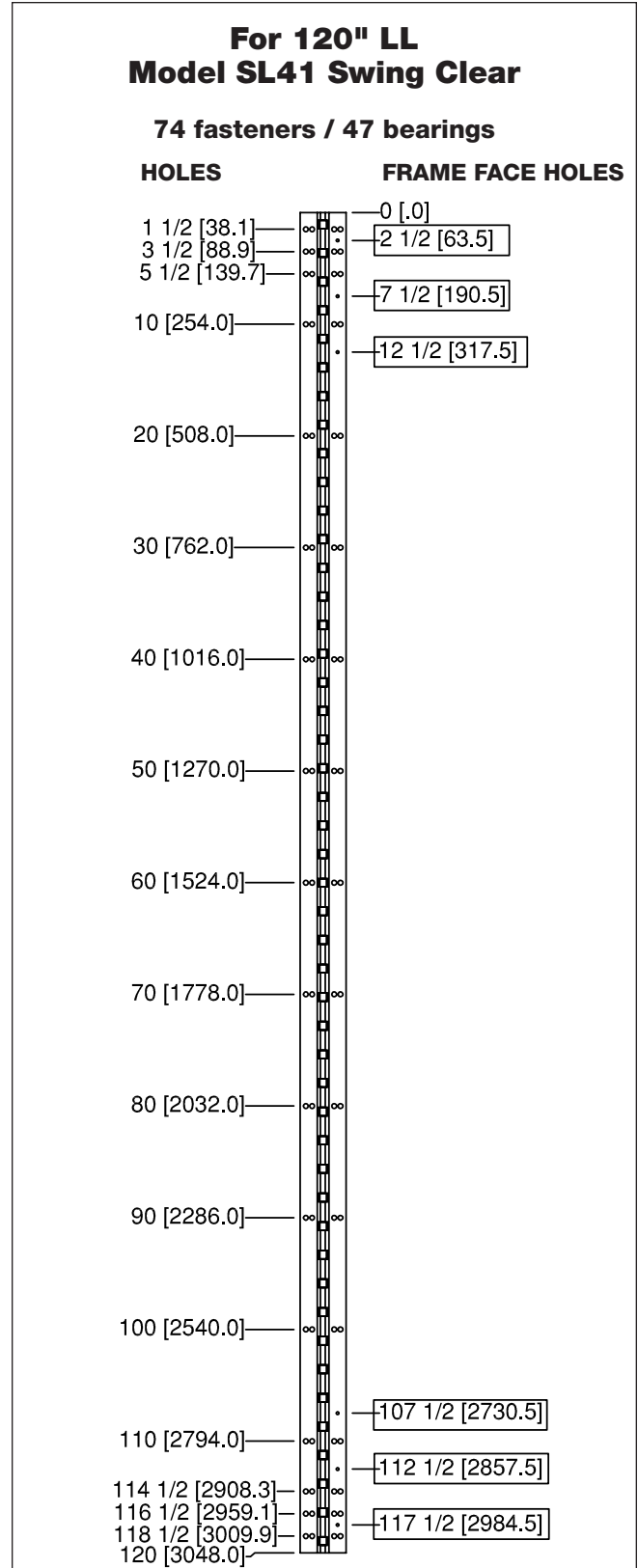
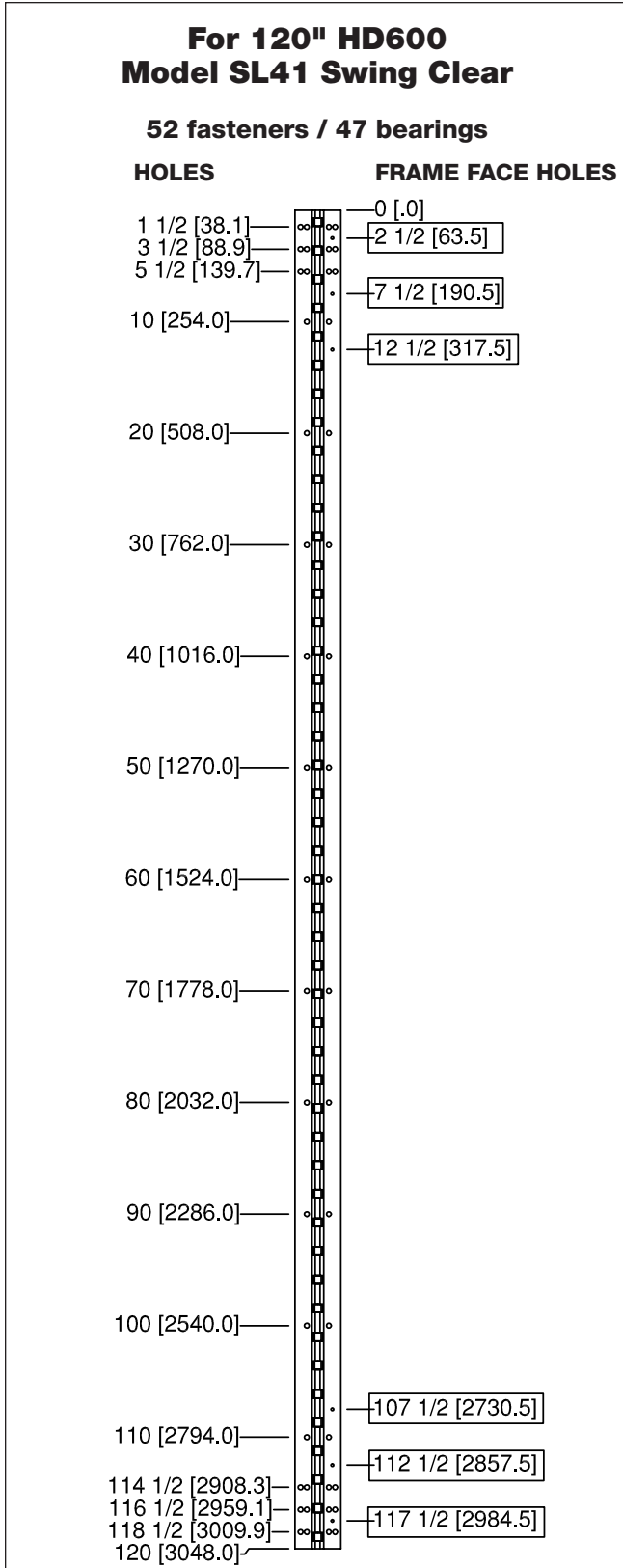


Swing Clear Geared Hinges

- All dimensions are measured in inches and [millimeters] from the top of the door to the centerline of the holes.
- Dimensions shown inside boxes are frame face mounting screw holes.

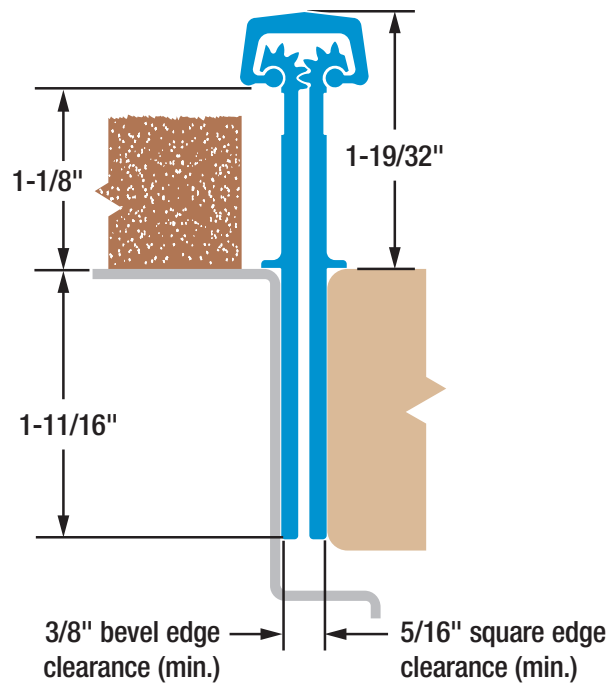


- All dimensions are measured in inches and [millimeters] from the top of the door to the centerline of the holes.
- Dimensions shown inside boxes are frame face mounting screw holes.





- Clearance of brick moldings or special door/frame designs
- Frame leaf covers butt hinge preps
- Flush mounted (no door inset)
- For 1-3/4" doors



SL40

Wide Throw Geared Continuous Hinge



Tested to last six decades



Reduce maintenance costs and hassles. Independent lab tests on an FRP door prove

SELECT hinges withstand 25 million cycles — more than 60 years of high-traffic use. Pair-Matched™ hinge leaves, lifetime lubrication and anodizing after machining deliver the longest life of any continuous hinge.

Covered by the only Continuous Warranty



Because SELECT geared continuous hinges have proven themselves in independent testing, we offer the industry's only Continuous Warranty. It

covers any failure of our aluminum geared continuous hinges — with no expiration date — as long as they are properly installed. Durability and worry-free performance ... guaranteed in writing. *The warranty that never ends for the hinge that never quits.SM*

Certified by U.S. Department of State



After brutal testing, the State Department granted a SELECT geared continuous hinge its 60-minute certification — the department's highest level. The hinge deflected bullets in the Ballistic Resistance Test and withstood sledgehammers,

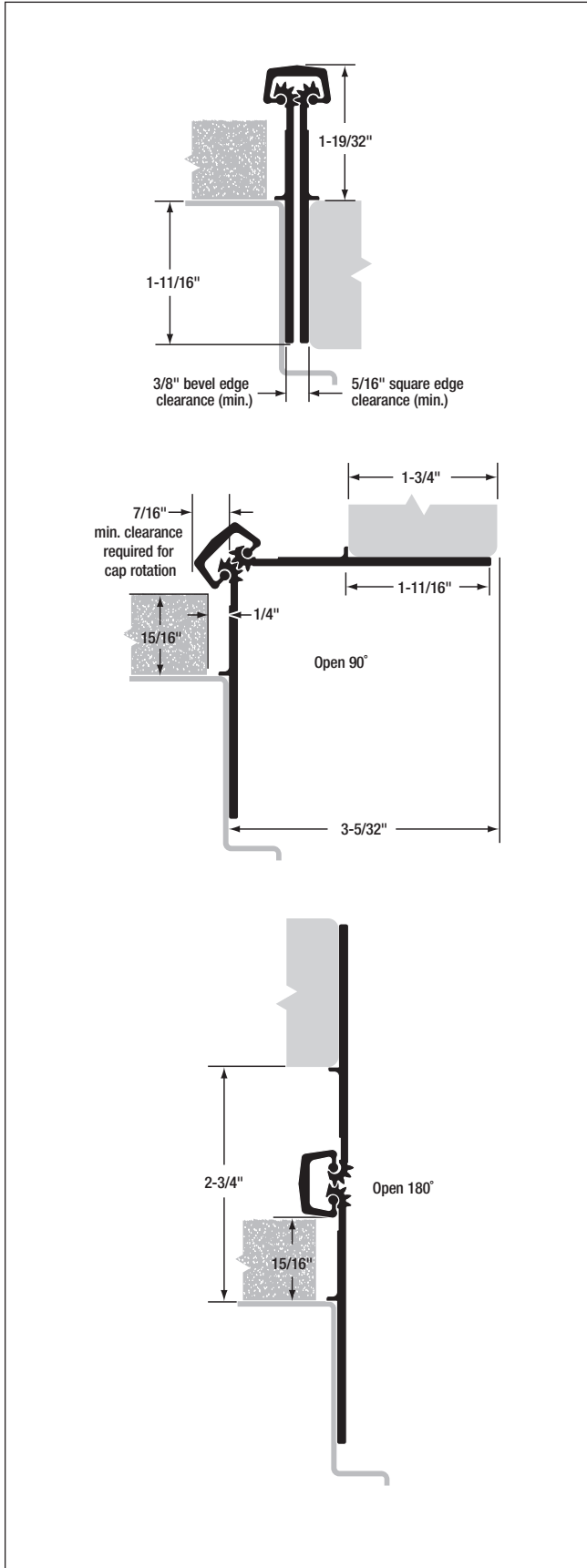
wedges and other tools in the Forced Entry Test. Approved for use in U.S. embassies overseas.

Geared to ship in 48 hours



SELECT ships hinges faster than anyone in the industry. 99.9% of our hinge orders ship in 48 hours; more than half are shipped in only 24 hours. Projects won't be delayed while waiting weeks for hinges.

NOTES:



MATERIAL: Extruded 6063 T6 aluminum alloy with self-lubricating polyester thrust bearings.

LENGTHS: 83" and 95" lengths standard for nominal door heights. Custom lengths are available.

LOAD/FREQUENCY RATING: For 1-3/4" doors. 48" max. door width in 16 gauge hollow metal (min.) or 1/8" aluminum (min.).

Heavy Duty 600 — For high-frequency doors up to 600 lb. Rivnuts are recommended in the frame and door when the door exceeds 450 lb.

FINISHES: All SL40 hinges are stocked in Clear and Dark Bronze anodized aluminum. Custom anodized or painted finishes are available. Product painted or anodized in the field voids the SELECT hinge warranty.

CLOSERS: Conventional overhead surface, concealed sliding arm overhead or floor closers may be used with SELECT hinges. Pivot-type floor closers (with a fixed, conflicting center pivot) must be replaced.

ORDER: Specify length, finish and heavy duty 600 (HD600). Also, specify door and frame screw applications. 12-24 x 3/4" self-drilling, thread-forming 410SS Phillips undercut flathead screws are provided as a standard pack unless otherwise specified. Wood and thread-forming screws also available. Security screws optional at extra cost.

AVAILABLE ELECTRIC PREPS: EPT, EMS and CMG. For EPT prep on this hinge model, please consult factory for engineering approval.



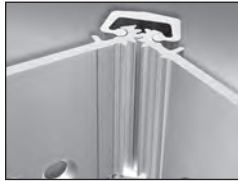
SL40 HINGE SCREW COUNT		
HINGE LENGTH & DUTY RATING	DOOR SCREWS	FRAME SCREWS
83" HD600	19	19
95" HD600	20	20

SELECT ADVANTAGES



PAIR-MATCHED™ HINGE LEAVES

Manufactured together, machined together and anodized together, making SELECT hinges fit your doors better and last longer. *An exclusive SELECT benefit.*



LIFETIME LUBRICATION

Eliminates the need for periodic maintenance. Quiet performance. Fights gear cap wear. *An exclusive SELECT benefit.*



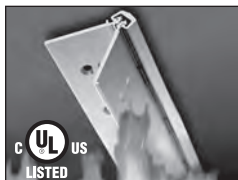
ANODIZED AFTER MACHINING

Delivers superior wear, durability and life. Inhibits corrosion. Few hinge makers follow SELECT's lead in using this superior manufacturing process.



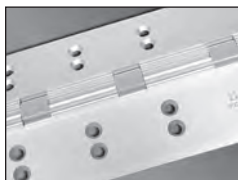
SUSTAINABLE

Made from up to 100% recycled aluminum. Reduces environmental impact and qualifies for LEED points. *An exclusive SELECT benefit.*



PATENTED 3-HR. FIRE RATING

Most SELECT hinges are fire rated for 90 minutes. 3-Hr. fire rating, optional at extra cost, approved for positive/negative pressure. No fire pins or studs required. Patented design innovation. *An exclusive SELECT benefit.*



CONSISTENT TEMPLATING

Hole pattern is identical on both Heavy Duty 300 and Heavy Duty 600 models, so SELECT hinges line up precisely for easier and faster installation. *An exclusive SELECT benefit.*



COATED FASTENERS

Provide additional corrosion protection with either self-drilling, thread-forming (SDTF) or thread-forming (TF) screws. *An exclusive SELECT benefit.*

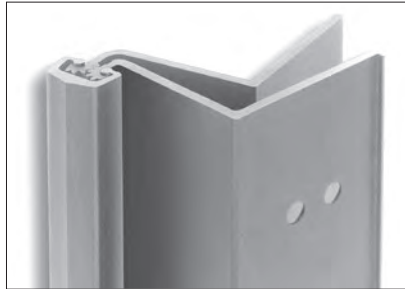


CUSTOM COLORS

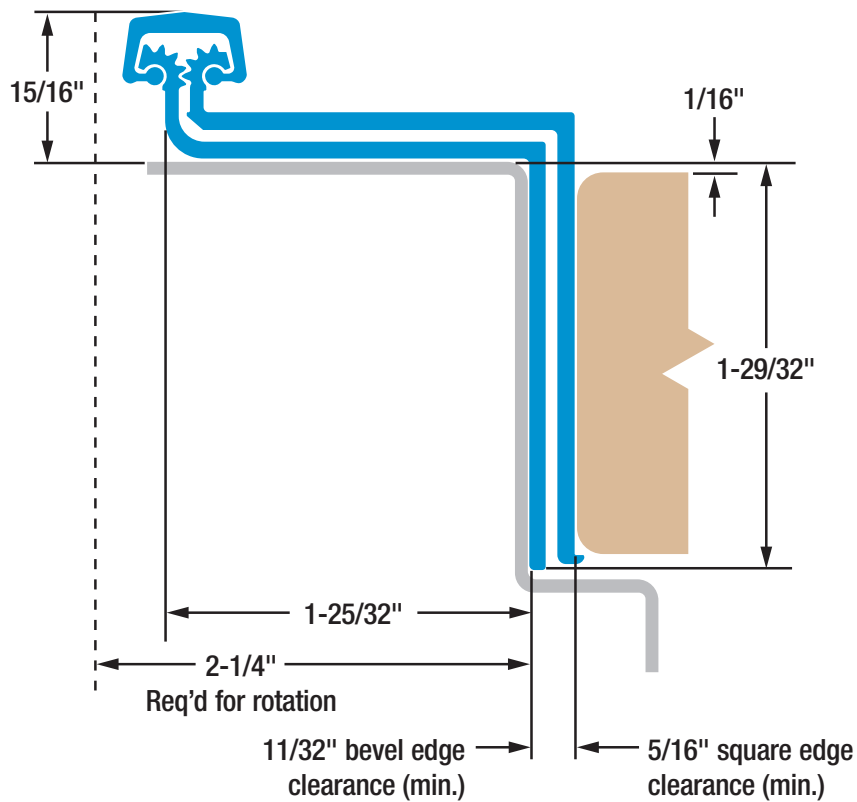
Match any paint color on the gear cap or the entire hinge and fasteners, including our always-in-stock Bone White gear caps. Anodized colors also available.

SELECT HINGE PERFORMANCE

- A SELECT geared continuous hinge has been tested in accordance with ANSI 250.4-1994 test procedure and acceptance criteria for physical endurance for steel doors and hardware and has surpassed 25,000,000 cycles during testing by an independent laboratory. On a door cycling 400,000 times per year, a SELECT hinge will be performing for over 62 years.
- SELECT geared continuous hinges are built to handle abuse from high-traffic applications. They are applied to the surface on the edge of the frame and door. No machining or reinforcement is required.
- The revolutionary SELECT geared continuous hinge puts an end to costly and irritating hinge failure problems, the most common cause of entrance failure.
- On conventional hinges, opening and “kick-back” energy concentrate on a few inches of fastened reinforcing plate — with the top hinge handling 100% of the force. Pinless SELECT hinges bond the door and frame into an integrated, sag-free unit. “Kick-back” energy dissipates along the entire length of the door and frame. (Compare this to a conventional hinge’s 4-1/2" to 5" at the top of the door and frame).
- SELECT geared continuous hinges eliminate the gap between the door and frame, providing a weatherproof, rust-proof, tamper-proof barrier. When the door is closed, there are no accessible screws, bolts or pins.
- SELECT SL40 geared continuous hinges are listed and tested by Underwriters Laboratories to meet the Positive and Negative pressure requirements of UL10B and UL10C, and are in accordance with UBC 7.2 (1997). SELECT SL40 geared continuous hinges are for use on swinging single fire doors (max. door opening of 4'x10') or pairs of fire doors (max. door opening of 8'x10'), including double egress, installed in masonry or drywall. SELECT SL40 geared continuous hinges are rated for up to 1-1/2 hours for wood composite and wood core type fire doors. A special patented process can be added to increase the fire rating to 3 hours (NO FIRE PINS OR STUDS REQUIRED) for hollow metal or steel covered composite type doors.



- Swing-clear action
- Door edge protector
- Requires 2-1/4" frame face for full rotation clearance
- 1/16" door inset
- For 1-3/4" doors



SL41 Swing Clear Geared Continuous Hinge



Tested to last six decades



Reduce maintenance costs and hassles. Independent lab tests on an FRP door prove

SELECT hinges withstand 25 million cycles — more than 60 years of high-traffic use. Pair-Matched™ hinge leaves, lifetime lubrication and anodizing after machining deliver the longest life of any continuous hinge.

Covered by the only Continuous Warranty



Because SELECT geared continuous hinges have proven themselves in independent testing, we offer the industry's only Continuous Warranty. It

covers any failure of our aluminum geared continuous hinges — with no expiration date — as long as they are properly installed. Durability and worry-free performance ... guaranteed in writing. *The warranty that never ends for the hinge that never quits.SM*

Certified by U.S. Department of State



After brutal testing, the State Department granted a SELECT geared continuous hinge its 60-minute certification — the department's highest level. The hinge deflected bullets in the Ballistic Resistance Test and withstood sledgehammers,

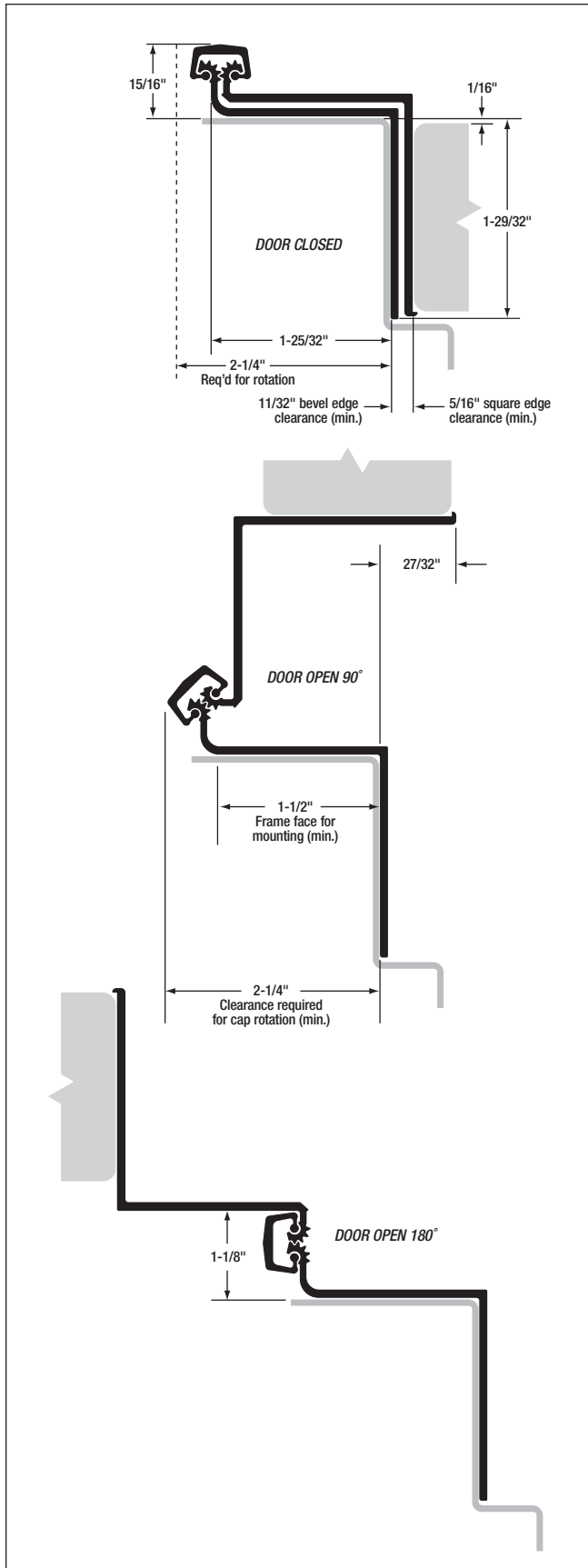
wedges and other tools in the Forced Entry Test. Approved for use in U.S. embassies overseas.

Geared to ship in 48 hours



SELECT ships hinges faster than anyone in the industry. 99.9% of our hinge orders ship in 48 hours; more than half are shipped in only 24 hours. Projects won't be delayed while waiting weeks for hinges.

NOTES:



MATERIAL: Extruded 6063 T6 aluminum alloy with self-lubricating polyester thrust bearings.

LENGTHS: 83", 85", 95" and 120" lengths standard for nominal door heights. Custom lengths are available.

LOAD/FREQUENCY RATINGS: For 1-3/4" doors. 48" max. door width in 16 gauge hollow metal (min.) or 1/8" aluminum (min.).

Heavy Duty 600 — For high-frequency doors up to 600 lb. Rivnuts are recommended in the frame and door when the door exceeds 450 lb.

Heavy Duty LL — Our heavy duty 600 with additional fastener holes for low- to medium-frequency doors up to 1,000 lb., including most lead-lined doors. Rivnuts are recommended in the frame and door on extremely tall, extremely heavy or extra-wide doors.

FINISHES: All SL41 hinges are stocked in Clear and Dark Bronze anodized aluminum. Custom anodized or painted finishes are available. Product painted or anodized in the field voids the SELECT hinge warranty.

CLOSERS: Conventional overhead surface, concealed sliding arm overhead or floor closers may be used with SELECT hinges. Pivot-type floor closers (with a fixed, conflicting center pivot) must be replaced.

ORDER: Specify length, finish and heavy duty (HD600) or heavy duty 600 with additional fastener holes (LL). Also, specify door and frame screw applications. 12-24 x 3/4" self-drilling, thread-forming 410SS Phillips undercut flathead screws are provided as a standard pack unless otherwise specified. Wood and thread-forming screws also available. Security screws optional at extra cost.

AVAILABLE ELECTRIC PREPS: EPT, EMS and CMG. For EPT prep on this hinge model, please consult factory for engineering approval.



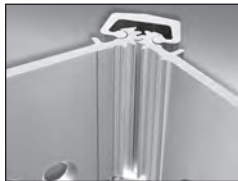
SL41 HINGE SCREW COUNT		
HINGE LENGTH & DUTY RATING	DOOR SCREWS	FRAME SCREWS
83" HD600	19	25
85" HD600	19	25
95" HD600	21	27
120" HD600	23	29
83" LL	26	32
85" LL	26	32
95" LL	30	36
120" LL	34	40

SELECT ADVANTAGES



PAIR-MATCHED™ HINGE LEAVES

Manufactured together, machined together and anodized together, making SELECT hinges fit your doors better and last longer. *An exclusive SELECT benefit.*



LIFETIME LUBRICATION

Eliminates the need for periodic maintenance. Quiet performance. Fights gear cap wear. *An exclusive SELECT benefit.*



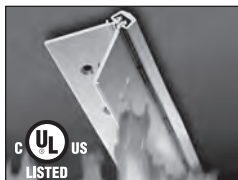
ANODIZED AFTER MACHINING

Delivers superior wear, durability and life. Inhibits corrosion. Few hinge makers follow SELECT's lead in using this superior manufacturing process.



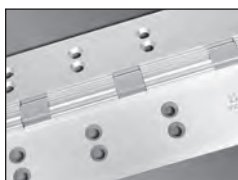
SUSTAINABLE

Made from up to 100% recycled aluminum. Reduces environmental impact and qualifies for LEED points. *An exclusive SELECT benefit.*



PATENTED 3-HR. FIRE RATING

Most SELECT hinges are fire rated for 90 minutes. 3-Hr. fire rating, optional at extra cost, approved for positive/negative pressure. No fire pins or studs required. Patented design innovation. *An exclusive SELECT benefit.*



CONSISTENT TEMPLATING

Hole pattern is identical on both Heavy Duty 300 and Heavy Duty 600 models, so SELECT hinges line up precisely for easier and faster installation. *An exclusive SELECT benefit.*



COATED FASTENERS

Provide additional corrosion protection with either self-drilling, thread-forming (SDTF) or thread-forming (TF) screws. *An exclusive SELECT benefit.*



CUSTOM COLORS

Match any paint color on the gear cap or the entire hinge and fasteners, including our always-in-stock Bone White gear caps. Anodized colors also available.

SELECT HINGE PERFORMANCE

- A SELECT geared continuous hinge has been tested in accordance with ANSI 250.4-1994 test procedure and acceptance criteria for physical endurance for steel doors and hardware and has surpassed 25,000,000 cycles during testing by an independent laboratory. On a door cycling 400,000 times per year, a SELECT hinge will be performing for over 62 years.
- SELECT geared continuous hinges are built to handle abuse from high-traffic applications. They are applied to the surface on the edge of the frame and door. No machining or reinforcement is required.
- The revolutionary SELECT geared continuous hinge puts an end to costly and irritating hinge failure problems, the most common cause of entrance failure.
- On conventional hinges, opening and “kick-back” energy concentrate on a few inches of fastened reinforcing plate — with the top hinge handling 100% of the force. Pinless SELECT hinges bond the door and frame into an integrated, sag-free unit. “Kick-back” energy dissipates along the entire length of the door and frame. (Compare this to a conventional hinge’s 4-1/2" to 5" at the top of the door and frame).
- SELECT geared continuous hinges eliminate the gap between the door and frame, providing a weatherproof, rust-proof, tamper-proof barrier. When the door is closed, there are no accessible screws, bolts or pins.
- SELECT SL41 geared continuous hinges are listed and tested by Underwriters Laboratories to meet the Positive and Negative pressure requirements of UL10B and UL10C, and are in accordance with UBC 7.2 (1997). SELECT SL41 geared continuous hinges are for use on swinging single fire doors (max. door opening of 4'x10') or pairs of fire doors (max. door opening of 8'x10'), including double egress, installed in masonry or drywall. SELECT SL41 geared continuous hinges are rated for up to 1-1/2 hours for wood composite and wood core type fire doors. A special patented process can be added to increase the fire rating to 3 hours (NO FIRE PINS OR STUDS REQUIRED) for hollow metal or steel covered composite type doors.

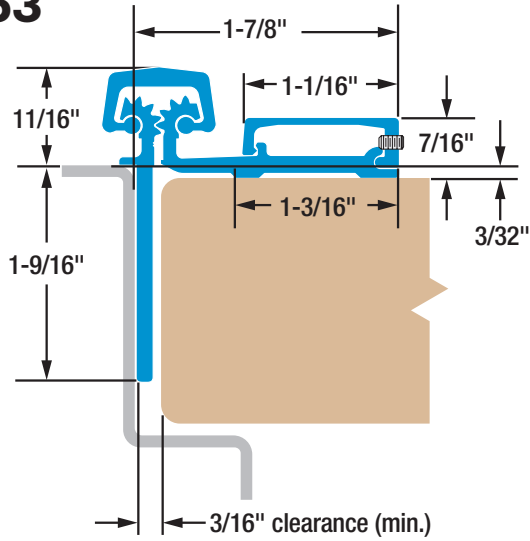


SELECT HINGES®

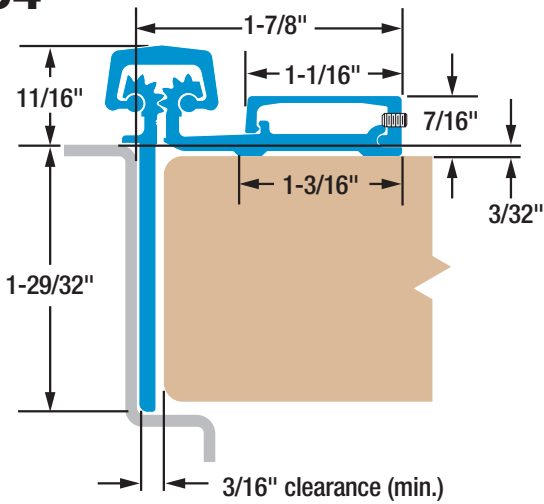
HALF SURFACE • HALF MORTISE GEARED HINGES

Half Surface

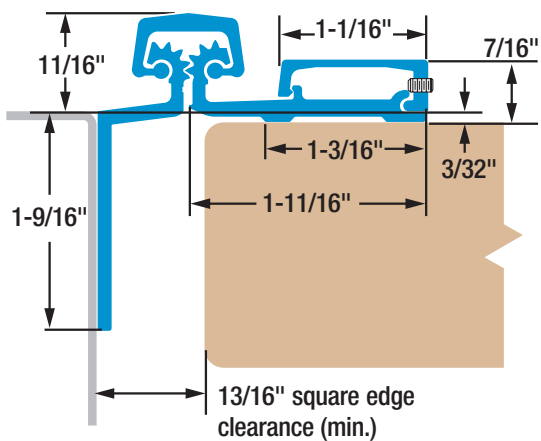
SL53



SL54

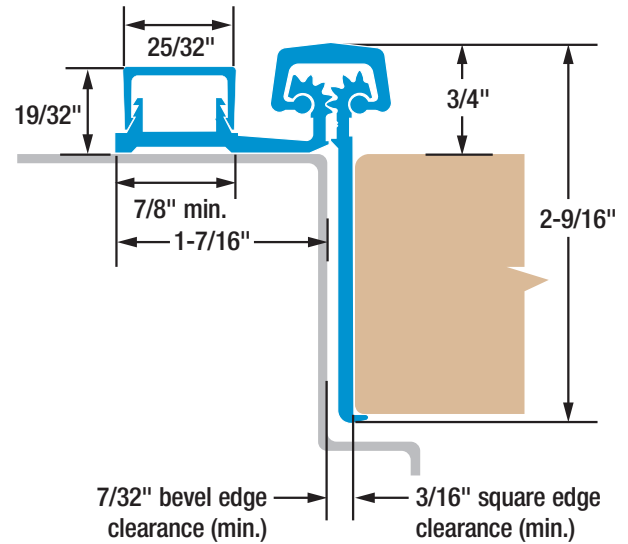


SL77



Half Mortise

SL52



HALF SURFACE • HALF MORTISE

HALF SURFACE • HALF MORTISE GEARED HINGES



PART NUMBER INTERCHANGE: HALF SURFACE • HALF MORTISE

SELECT MODELS	NGP	ROTON	PEMKO	STANLEY	ABH	PBB	IVES
SL52 HD600			HMHD				
SL53 HD600	HD5300	780-053HD		679HD	A530HD	CG34N	053XY**
SL54 HD600	HD5400	780-054HD	HSHD	663HD	A540HD	CG34	054XY**
SL77 HD600		780-155HD	HSSFHD	680HD	550HD		

* Not equivalent hinge but possible SELECT hinge substitution depending on application.

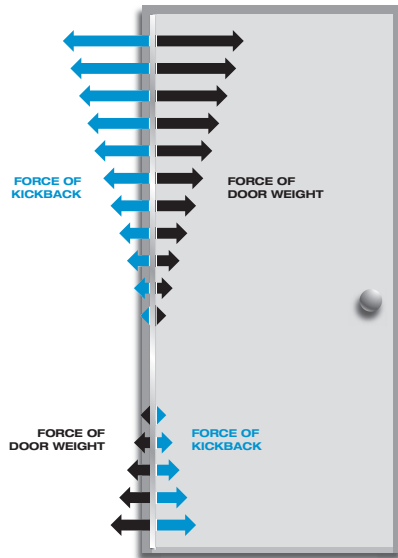
** Compatible with inset & profile.

No equivalent hinge available from this manufacturer.

HINGE STRESS COMPARISON

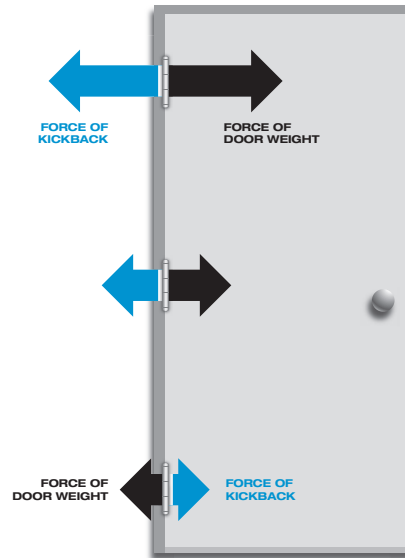
CONTINUOUS HINGES

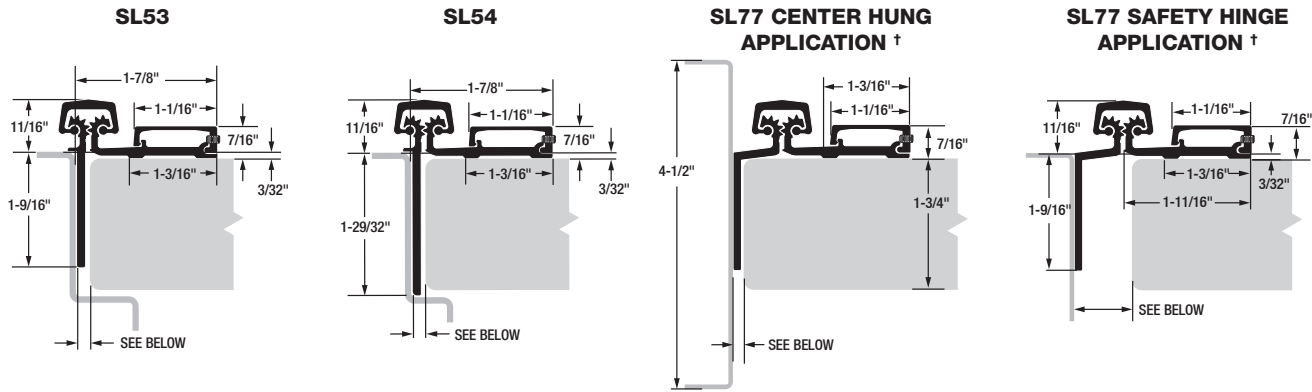
SELECT continuous hinges unite the door and frame into an integrated, sag-free unit. "Kickback" energy dissipates along the entire length of the door and frame and prevents hinge failure.



CONVENTIONAL BUTT HINGES

On conventional hinges, opening and "kickback" energy from closers and automatic operators concentrates on the top butt hinge. This force works against the top hinge, eventually forcing it apart or pulling it from the frame/door.





† Please note the SL77 is not fire-rated.

Door Clearances

For Square and Beveled-Edge Doors

IMPORTANT: All uncut SL53, SL54 and SL77 hinges are non-handed and templated. They become handed after cutting. If door inset is required, install a continuous piece of shim under the door leaf.

* **NOTE:** Refer to NFPA 80 manual for clearance requirements on fire-rated entrances.

Important Warranty Information:

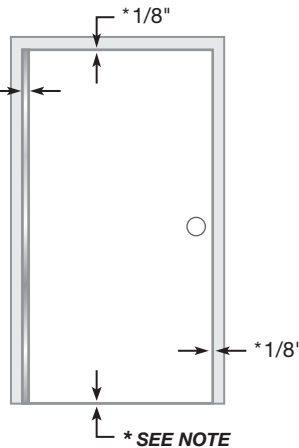
The following actions will void any warranty, expressed or implied:

- Failure to install the hinge according to manufacturer's specifications and requirements. (For more information, visit selecthingerequirements.com.)
- Use of fasteners other than those supplied with the hinge.
- Unauthorized field modifications, including alteration or removal of the factory-applied lubricant, altering the original finish or painting the hinge.

Single Door

Hinge side clearance

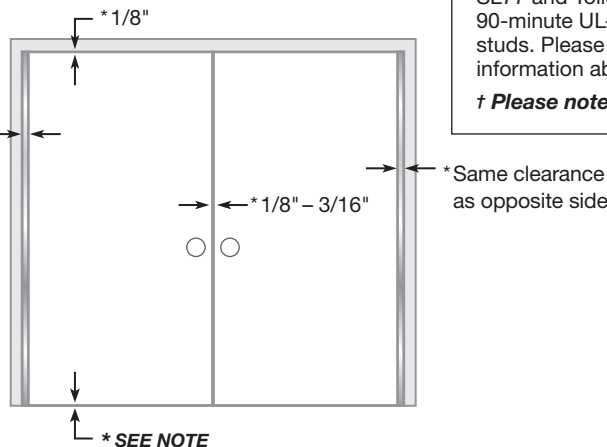
SL53 & SL54	*3/16"
SL77 Center Hung	5/32"
SL77 Safety Hinge	13/16"



Double Doors (Pair)

Hinge side clearance

SL53 & SL54	*3/16"
SL77 Center Hung	5/32"
SL77 Safety Hinge	13/16"



Reinforcing & Rivnuts®

No hinge reinforcement is necessary except on extremely high-frequency, extremely tall, extremely heavy or extra-wide doors. Rivnuts are recommended for use in the frame when the door exceeds 450 lb.

NOTE: Only SELECT steel Rivnuts® are to be used with fire-rated SELECT hinges.

Grouted/Slushed-in Frames

For ease of installation, it is recommended some sort of mudguard be installed behind the frame. Do not use self-drilling, thread-forming (SDTF) screws to drill into grouted frames. If mudguards have not been used, carefully drill pilot holes through frame and remove grout for screw clearance. Do not oversize holes in frame.

Fire-Rated Hinges †

All SELECT hinges (except SL71, SL77 and Toilet Partition hinges) are 90-minute UL-rated, without fire pins or studs. Please contact SELECT for complete information about its fire-rated hinges.

† Please note the SL77 is not fire-rated.



Tools Needed

- Metal-cutting saw
- Tape measure
- #13 or 3/16" drill bit & 3/8" drill bit
- 5/32" drill bit (wood frames only)
- #3 Phillips drive
- 5/64" Allen wrench
- Hammer
- Shims

Parts Supplied

- #12-24 self-drilling, thread-forming (SDTF) 410 SS Phillips undercut flathead screws
- #12-24 self-drilling, thread-forming (SDTF) 410 SS Phillips undercut panhead screws
- 1/4-20 barrel nuts (through bolts)
- 1/4-20 shoulder screws
- 7/32" center punch
- 3/8" center punch
- Set screws

Optional Parts

- #12 410 SS Phillips undercut flathead wood screws
- #12-24 thread-forming (TF) 410 SS Phillips undercut flathead screws
- Long barrel nuts for doors 2"–2-1/4" thick
- Protective gloves are recommended

How to Cut the Hinge to Fit

- A. Keep hinge in "door closed" position (Fig. 1).
- B. Determine whether this will be a right-hand or left-hand installation.

IMPORTANT: Cut only one end of hinge. Cut end will be installed at the bottom. Keep original templated six-hole pattern at top end of hinge.

- C. Using a metal-cutting saw, begin the cut through the gear cap first.

NOTE: DO NOT cut through a set screw bearing.

- D. Loosen set screw from side of door leaf cover with 5/64" Allen wrench (Fig. 1).
- E. Remove door leaf cover by sliding it off uncut end of hinge.
- F. Reinstall any set screw bearing that may have been cut off.

A. Attach Hinge to Frame

NOTE: Remove door leaf cover if not already removed. See step D above.

1. Shim hinge to 1/8" below the header to allow for door clearance.
2. Hold hinge in "door open" position (Fig. 2) making sure frame leaf alignment flange is tight against frame rabbet.
3. Mark (or centerpunch) two holes at top and two holes at bottom of frame leaf.

NOTE: TF screws and wood screws require pilot holes at marked locations. SDTF screws do not require pilot holes.

Fig. 1 Door Closed Position

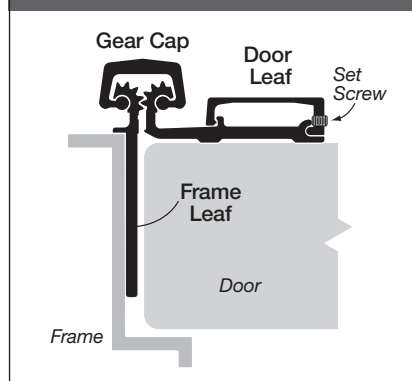


Fig. 2 Door Open 90°

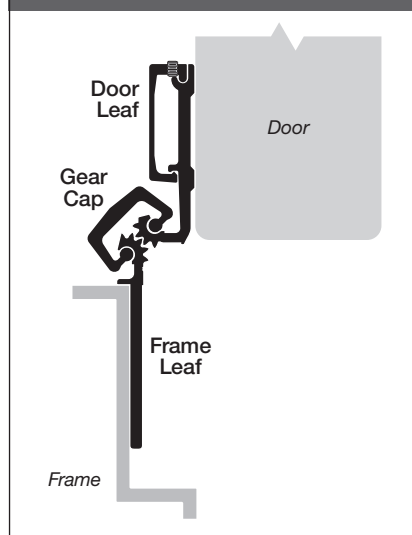
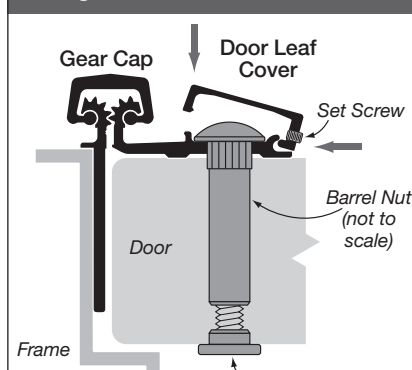


Fig. 2 Leaf Cover Installation



SECURED SIDE, OUTSWING

NOTE: For inswing applications, reverse position of barrel nut and shoulder screw so that the shoulder screw is on the secured side of the door.

4. If using SDTF screws, go to Step 5. If using TF or wood screws, drill holes at marked locations.
 - Metal frame: Use #13 (.185") bit or 3/16" (.188") bit
 - Wood frame: Use a 5/32" (.156") bit
5. Fasten frame leaf to door frame using two screws at the top and two screws at the bottom.
 - Metal frame: Use #12-24 TF flathead screws provided, or use #12-24 SDTF flathead screws (provided on request)
 - Wood frame: Use #12 flathead wood screws (provided on request)

B. Prepare Door

6. Shim door into opening to provide required hinge clearances.

IMPORTANT: Top end of the hinge must be flush with the top of the door.

IMPORTANT: A 13/16" gap between door edge and a frame without a stop is necessary for the SL77 safety feature to be effective. See illustration on other side.

7. Mark locations for the four SDTF panhead screws on the door using 7/32" center punch.
8. With #3 Phillips drive, temporarily attach door leaf to door through the four locator holes with SDTF panhead screws provided.
9. Remove shims and check door clearances, alignment and operation.

NOTE: Door may sag slightly when shims are removed. Note the amount of adjustment needed to bring door back into alignment.

DO NOT PROCEED UNTIL DOOR OPERATES PROPERLY.

10. Mark locations for barrel nuts on the door using 3/8" center punch.
11. Remove door and lay it flat. Use 3/8" drill bit to drill holes at marked locations.

NOTE: Be sure to drill squarely through door.

C. Attach Door to Hinge

12. Fasten door to door leaf with the barrel nuts and 1/4-20 shoulder screws.

NOTE: Always install shoulder screws on the secured side of the door (Fig. 3).

13. Mark (or centerpunch) remaining frame leaf hole locations. Drill holes in frame through the frame leaf and secure with flathead screws.

14. Secure door to door leaf with barrel nuts and 1/4-20 shoulder screws.

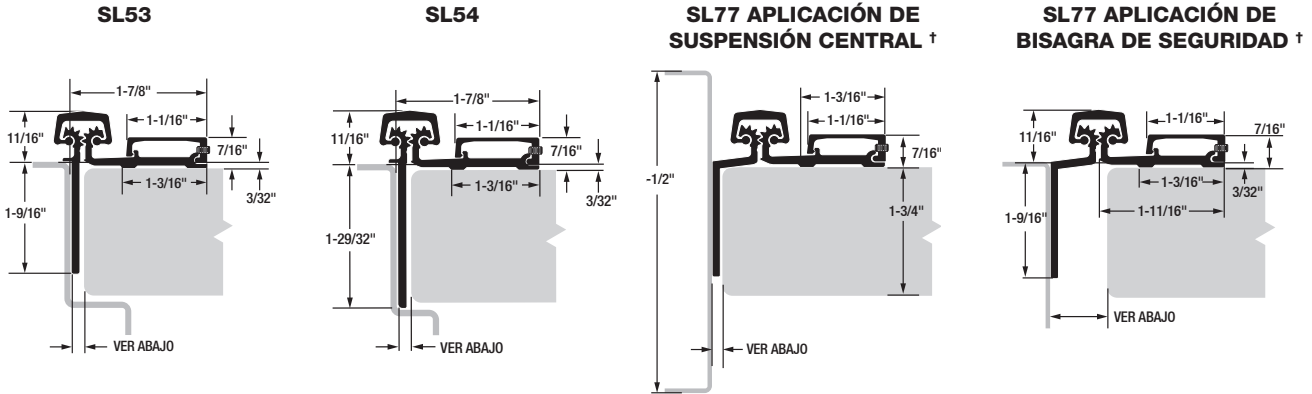
NOTE: Always install shoulder screws on the secured side of the door (Fig. 3).

D. Install Leaf Cover

15. Align leaf cover with top edge of hinge.
16. Starting from the top and working downward, apply pressure to leaf cover to snap it into place (Fig. 3).

NOTE: If you use a hammer to tap cover into place, be sure to protect the surface of the cover from damage.

17. Tighten set screws with 5/64" Allen wrench.



† Tenga presente que SL77 no es de clasificación ignífuga.

Espacios libres de puerta

Para puertas de borde cuadrado y de borde biselado

IMPORTANTE: Todas las bisagras SL53, SL54 y SL77 sin cortar son invertibles y con plantilla y se vuelven no invertibles después del corte. Si se requiere que la puerta tenga holgura, coloque un trozo de cuña continuo debajo de la hoja de la puerta.

* **NOTA:** Consulte el manual NFPA 80 para ver los requisitos de espacio libre en las entradas con clasificación ignífuga.

Información importante sobre la garantía:

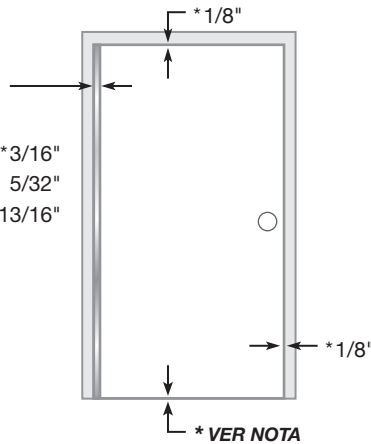
Las acciones siguientes invalidarán cualquier garantía, ya sea explícita o implícita:

- No instalar la bisagra siguiendo las especificaciones y requisitos del fabricante. (Visite selecthingerequirements.com para obtener más información)
- Usar sujetadores que no sean los que se suministran con la bisagra.
- Modificaciones de terreno no autorizadas, como alterar o retirar el lubricante aplicado en la fábrica, alterar el acabado original o pintar la bisagra.

Puerta simple

Espacio libre en lado de bisagra

SL53 y SL54	* 3/16"
SL77 Suspensión central	5/32"
SL77 Bisagra de seguridad	13/16"

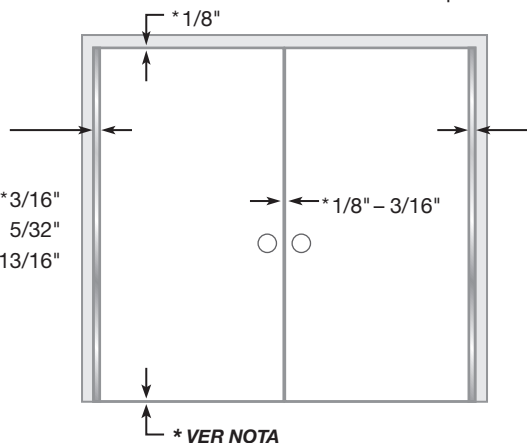


* Igual espacio libre que el lado opuesto

Puertas dobles (par)

Espacio libre en lado de bisagra

SL53 y SL54	* 3/16"
SL77 Suspensión central	5/32"
SL77 Bisagra de seguridad	13/16"



Refuerzo y Rivnuts®

No se requiere refuerzo de bisagra excepto en puertas extra anchas, extremadamente pesadas o de frecuencia extremadamente alta. Se recomienda usar Rivnuts en el marco cuando la puerta pesa más de 450 lb. (máx. 600 lb.)

NOTA: Con las bisagras SELECT de clasificación ignífuga solo se deben usar Rivnuts® de acero SELECT.

Marcos enlechados / Rellenos con mortero

Para facilitar la instalación, se recomienda instalar algún tipo de guardalodos detrás del marco. No use tornillos autoperforantes y autorroscantes (SDTF) para perforar los marcos enlechados. Si no se utilizaron guardalodos, barre el marco con cuidado para crear orificios piloto y retire la lechada para asegurar la holgura del tornillo. Asegúrese de que los orificios del marco no sean demasiado grandes.

Bisagras de clasificación ignífuga†



Todas las bisagras SELECT en inventario están homologadas por UL para 90 minutos, sin pasadores. Contacte a SELECT para obtener toda la información sobre estas bisagras de clasificación ignífuga.

† Tenga presente que SL77 no es de clasificación ignífuga

Herramientas necesarias

- Sierra para cortar metal
- Cinta para medir
- Broca N° 13 o de 3/16" y broca de 3/8"
- Broca de 5/32" (solamente para marcos de madera)
- Destornillador Phillips N° 3
- Llave Allen de 5/64"
- Martillo
- Cuñas

Piezas suministradas

- Tornillos Phillips roscadores autorroscantes (SDTF) de acero inoxidable N° 12-24 de cabeza plana sesgada
- Tornillos Phillips de acero inoxidable 410 roscadores autorroscantes (SDTF) N° 12-24 de cabeza troncocónica sesgada
- Tuercas cilíndricas de 1/4-20
- Tornillos de tope de 1/4-20
- Punzón de 7/32"
- Punzón de 3/8"
- Tornillos de ajuste

Piezas opcionales

- Tornillos Phillips de acero inoxidable 410 N° 12 de cabeza plana sesgada, para madera
- Tornillos Phillips de acero inoxidable 410 roscadores (TF) N° 12-24 de cabeza plana sesgada
- Tuercas cilíndricas largas para puertas de 2" a 2 1/4" de grosor
- Se recomienda el uso de guantes protectores

Cómo cortar la charnela al tamaño

- A. Mantenga la charnela en la posición de "puerta cerrada" (Fig.1).
- B. Determine si ésta será una instalación para diestros o zurdos.

IMPORTANTE: Corte solamente un extremo de la charnela. El extremo cortado se instalará en la parte inferior. Guarde el patrón de templado original de seis orificios en el extremo superior de la charnela.

- C. Usando una sierra para cortar metal, comience el corte primero por la tapa de la charnela.

NOTA: NO corte por el rodamiento del tornillo de ajuste.

- D. Afloje el tornillo opresor del lado de la cubierta de la hoja de la puerta con una llave Allen de 5/64" (Fig. 1).
- E. Quite la cubierta de la hoja de la puerta deslizando la por el extremo sin cortar de la charnela.
- F. Vuelva a instalar cualquier rodamiento del tornillo de ajuste que pudiera haberse cortado.

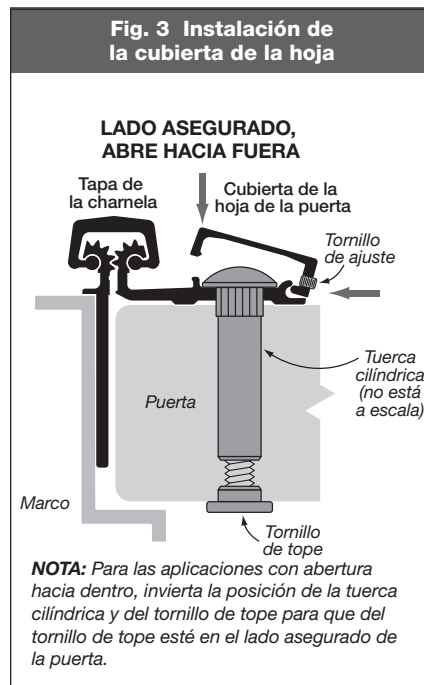
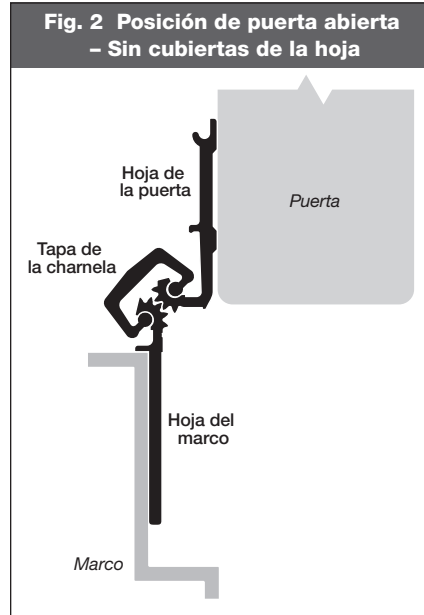
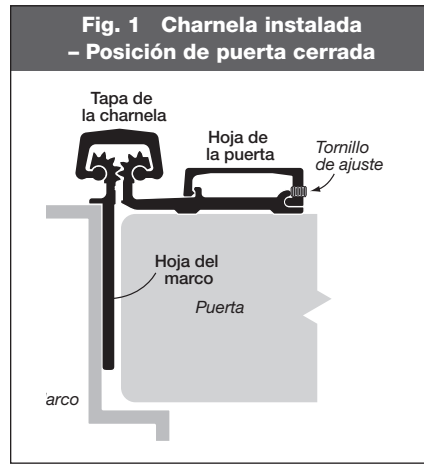
A. Fije la charnela al marco

NOTA: Retire la cubierta de la hoja de la puerta si no lo ha hecho todavía. Vea el paso D arriba.

1. Coloque cuñas en la charnela a 1/8" debajo del travesaño para dejar tolerancia para la puerta.
2. Sostenga la charnela en la posición de "puerta abierta" (Fig. 2) y asegúrese de que el reborde de alineación de la hoja del marco esté ajustado contra la cara del marco.
3. Marque (o punce) dos orificios en la parte superior y dos orificios en la parte inferior de la hoja del marco.

NOTA: Los tornillos roscadores (TF) y los de madera necesitan orificios piloto en las ubicaciones marcadas. Los tornillos roscadores autorroscantes (SDTF) no necesitan orificios piloto.

4. Si va a usar tornillos roscadores autorroscantes (SDTF), vaya al paso 5. Si va a usar tornillos roscadores (TF) o para madera, taladre orificios en los lugares marcados.



NOTA: Para las aplicaciones con abertura hacia dentro, invierta la posición de la tuerca cilíndrica y del tornillo de tope para que del tornillo de tope esté en el lado asegurado de la puerta.

- Marco de metal: Use una broca N° 13 (0,185") o de 3/16" (0,188")
 - Marco de madera: Use una broca de 5/32" (0,156")
5. Sujete la hoja del marco al marco de la puerta usando dos tornillos en la parte superior y dos tornillos en la parte inferior.
 - Marco de metal: Use los tornillos de cabeza plana roscadores TF N° 12-24 provistos o use tornillos de cabeza plana roscadores autorroscantes (SDTF) N° 12-24 (provistos bajo pedido)
 - Marco de madera: Use tornillos de cabeza plana para madera N° 12 (provistos bajo pedido)

B. Preparación de la puerta

6. Acuñe la puerta en la abertura para proporcionar las tolerancias requeridas para la charnela.

IMPORTANTE: El extremo superior de la charnela debe estar alineado con la parte superior de la puerta.

7. Marque las ubicaciones para los cuatro tornillos roscadores autorroscantes (SDTF) de cabeza troncocónica en la puerta usando el punzón de 7/32".
8. Con el destornillador Phillips N° 3, sujete provisoriamente la hoja de la puerta a la puerta a través de los cuatro orificios de ubicación con los tornillos roscadores autorroscantes (SDTF) de cabeza troncocónica provistos.
9. Quite las cuñas y verifique las tolerancias, la alineación y el funcionamiento de la puerta.

NOTA: La puerta puede caerse ligeramente cuando se quitan las cuñas. Fíjese cuánto debe ajustar la puerta para alinearla. **NO CONTINÚE HASTA QUE LA PUERTA FUNCIONE COMO ES DEBIDO.**

10. Marque las ubicaciones para las tuercas cilíndricas en la puerta usando el punzón de 3/8".
11. Retire la puerta y colóquela en posición horizontal. Use una broca de 3/8" para taladrar los orificios en los lugares marcados.

NOTA: Cerciórese de taladrar la puerta en forma recta.

C. Fije la puerta a la charnela

12. Asegure la puerta a la hoja de la puerta con las tuercas cilíndricas y los tornillos de tope de 1/4-20.

NOTA: Instale los tornillos de tope siempre en el lado asegurado de la puerta (Fig. 3).

13. Marque (o punce) los lugares restantes de los orificios de la hoja del marco. Taladre los orificios en el marco a través de la hoja del marco y asegúrelos con los tornillos de cabeza plana.
14. Asegure la puerta a la hoja de la puerta con las tuercas cilíndricas y los tornillos de tope de 1/4-20.

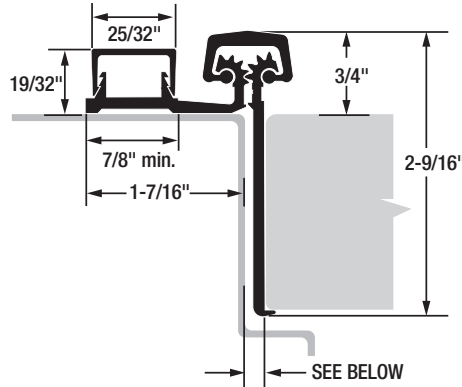
NOTA: Instale los tornillos de tope siempre en el lado asegurado de la puerta (Fig. 3).

D. Instale la cubierta de la hoja

15. Alinee la cubierta de la hoja con el extremo superior de la charnela.
16. Comenzando desde la parte superior y trabajando hacia abajo, aplique presión a la cubierta de la hoja para encajarla en su lugar (Fig. 3).

NOTA: Si usa un martillo para colocar la cubierta en su lugar, dé pequeños golpes asegurándose de proteger de daños la superficie de la cubierta.

17. Apriete los tornillos de ajuste con una llave Allen de 5/64".



Important Warranty Information:

The following actions will void any warranty, expressed or implied:

- Failure to install the hinge according to manufacturer's specifications and requirements. (For more information, visit selecthingerequirements.com.)
- Use of fasteners other than those supplied with the hinge.
- Unauthorized field modifications, including alteration or removal of the factory-applied lubricant, altering the original finish or painting the hinge.

Door Clearances

For Square and Beveled-Edge Doors

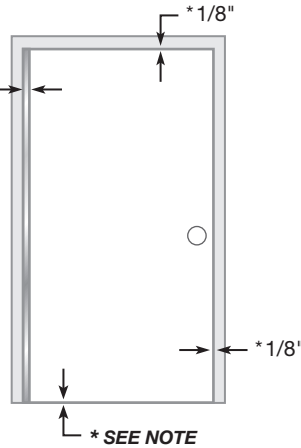
IMPORTANT: All uncut SL52 hinges are non-handed and templated. They become handed after cutting. If door inset is required, install a continuous piece of shim under the door leaf.

*** NOTE:** Refer to NFPA 80 manual for clearance requirements on fire-rated entrances.

Single Door

Hinge side clearance

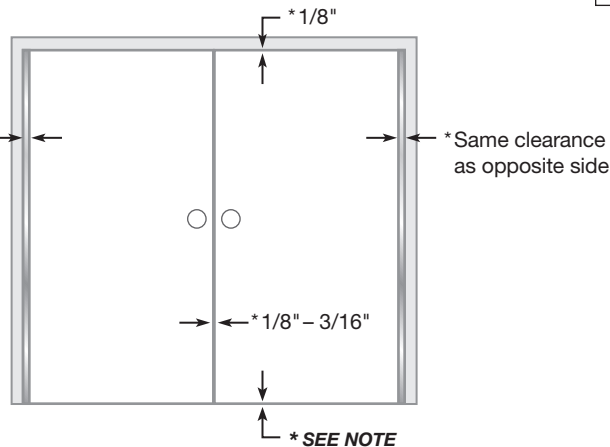
Square Edge	*3/16"
Beveled Edge	*7/32"



Double Doors (Pair)

Hinge side clearance

Square Edge	*3/16"
Beveled Edge	*7/32"



Reinforcing & Rivnuts®

No hinge reinforcement is necessary except on extremely high-frequency, extremely tall, extremely heavy or extra-wide doors. Rivnuts are recommended for use in the door when the door exceeds 450 lb.

NOTE: Only SELECT steel Rivnuts are to be used with fire-rated SELECT hinges.

Grouted/Slushed-in Frames

For ease of installation, it is recommended some sort of mudguard be installed behind the frame. Do not use self-drilling, thread-forming (SDTF) screws to drill into grouted frames. If mudguards have not been used, carefully drill pilot holes through frame and remove grout for screw clearance. Do not oversize holes in frame.

Fire-Rated Hinges

All SELECT hinges (except SL71, SL77 and Toilet Partition hinges) are 90-minute UL-rated, without fire pins or studs. Please contact SELECT for complete information about its fire-rated hinges.



Tools Needed

- Metal-cutting saw
- Tape measure
- #13 or 3/16" drill bit
- 5/32" drill bit (wood frames only)
- #3 Phillips drive
- 5/64" Allen wrench
- Hammer
- Shims

Parts Supplied

- #12-24 self-drilling, thread-forming (SDTF) 410 SS Phillips undercut flathead screws
- #12-24 self-drilling, thread-forming (SDTF) 410 SS Phillips undercut panhead screws
- 7/32" center punch

Optional Parts

- #12 410 SS Phillips undercut flathead wood screws
- #12-24 thread-forming (TF) 410 SS Phillips undercut flathead screws
- Protective gloves are recommended

NOTE: All holes in the hinge must be drilled correctly and fasteners properly installed. Failure to use the fasteners supplied by Select Products Limited will void the UL fire rated listing.

NOTE: The Screw Pack contains TF sheet metal or SDTF self-drilling screws for the door and frame. Wood x metal or all-wood screw packs are available upon request.

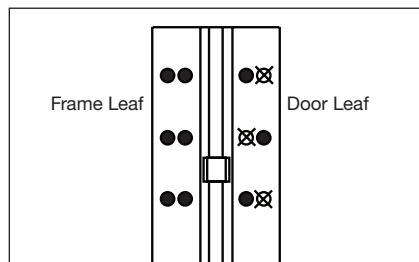
A. Attach Hinge to Door

NOTE: DO NOT install snap-on leaf cover until installation is 100% complete, and all aspects of the assembly are correctly fastened and properly fitted.

1. Place door leaf on door edge and align hinge with top of door and door edge protector, noting door handing if required.

IMPORTANT: Top end of the hinge must be flush with the top of the door.

IMPORTANT: If installing hinge on a 90-minute fire-rated wood door, mark or centerpunch only one hole in each pair of holes at the top and bottom of the door leaf. DO NOT install remaining screws in the six-hole pattern on the door leaf. See illustration below.



2. Mark (or centerpunch) hole locations.

NOTE: TF screws and wood screws require pilot holes at marked locations. SDTF screws do not require pilot holes.

3. If using SDTF screws, go to Step 4. If using TF or wood screws, drill holes at marked locations.
 - Metal door: Use #13 (.185") bit or 3/16" (.188") bit
 - Wood door: Use 5/32" (.156") bit.
4. Fasten door leaf to door using #3 Phillips drive and fasteners provided.

B. Prepare Frame

5. Shim door into opening to provide required hinge clearances. A 1/8" gap between the top of the door and header, and 1/8" gap at the lock side of the door should be maintained.
6. When the door is in position, fold the frame leaf over the face of the frame and mark the top and bottom holes. Fasten the hinge accordingly depending on which screws are being used (Fig. 2).
7. Remove shims and check door swing and alignment. Make any adjustments necessary to maintain proper clearances.

NOTE: Door may sag slightly when shims are removed. Note the amount of adjustment needed to bring door back into alignment.

DO NOT PROCEED UNTIL DOOR OPERATES PROPERLY.

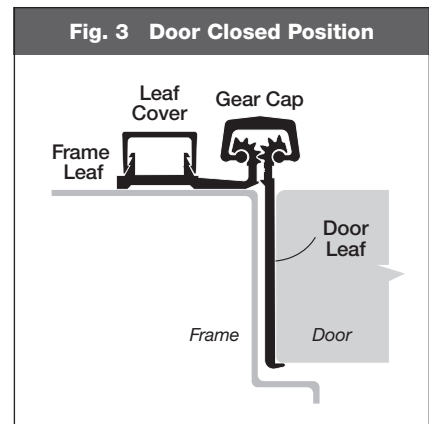
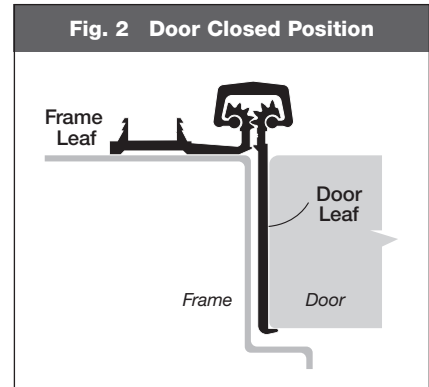
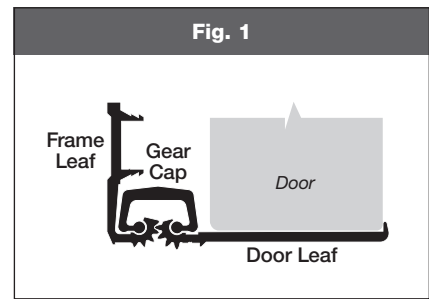
8. Install remaining fasteners once hinge is in proper position.

C. Install Frame Leaf Cover

9. Align leaf cover with top edge of hinge.
10. Starting from the top and working downward, apply pressure to leaf cover to snap it into place (Fig. 3).

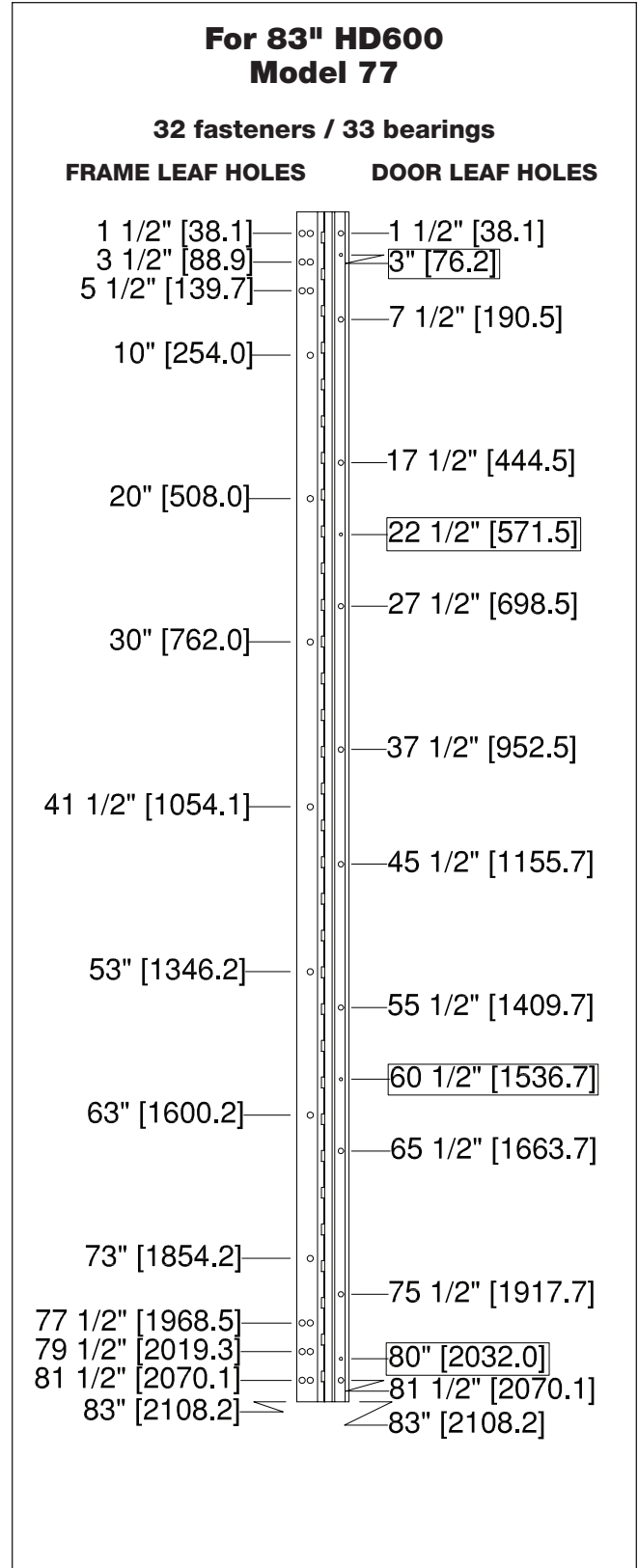
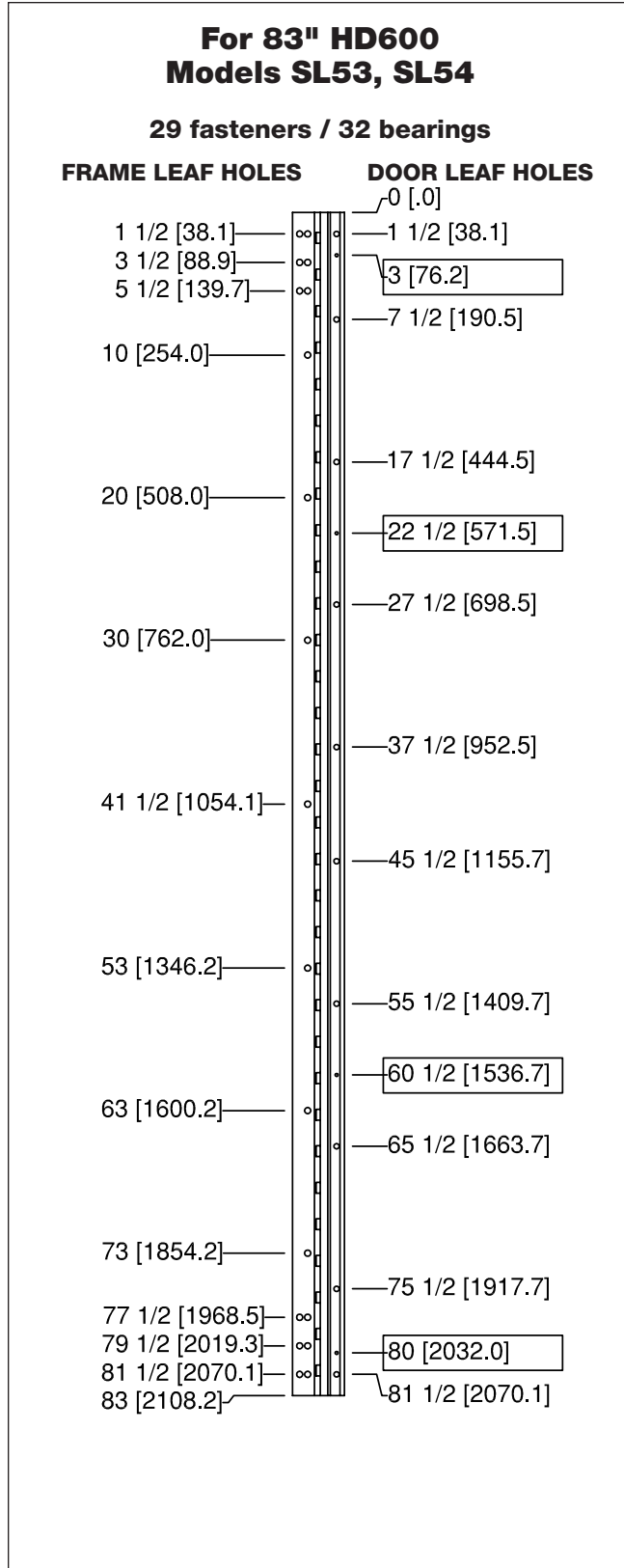
NOTE: If you use a hammer to tap cover into place, be sure to protect the surface of the cover from damage.

17. Tighten set screws with 5/64" Allen wrench.

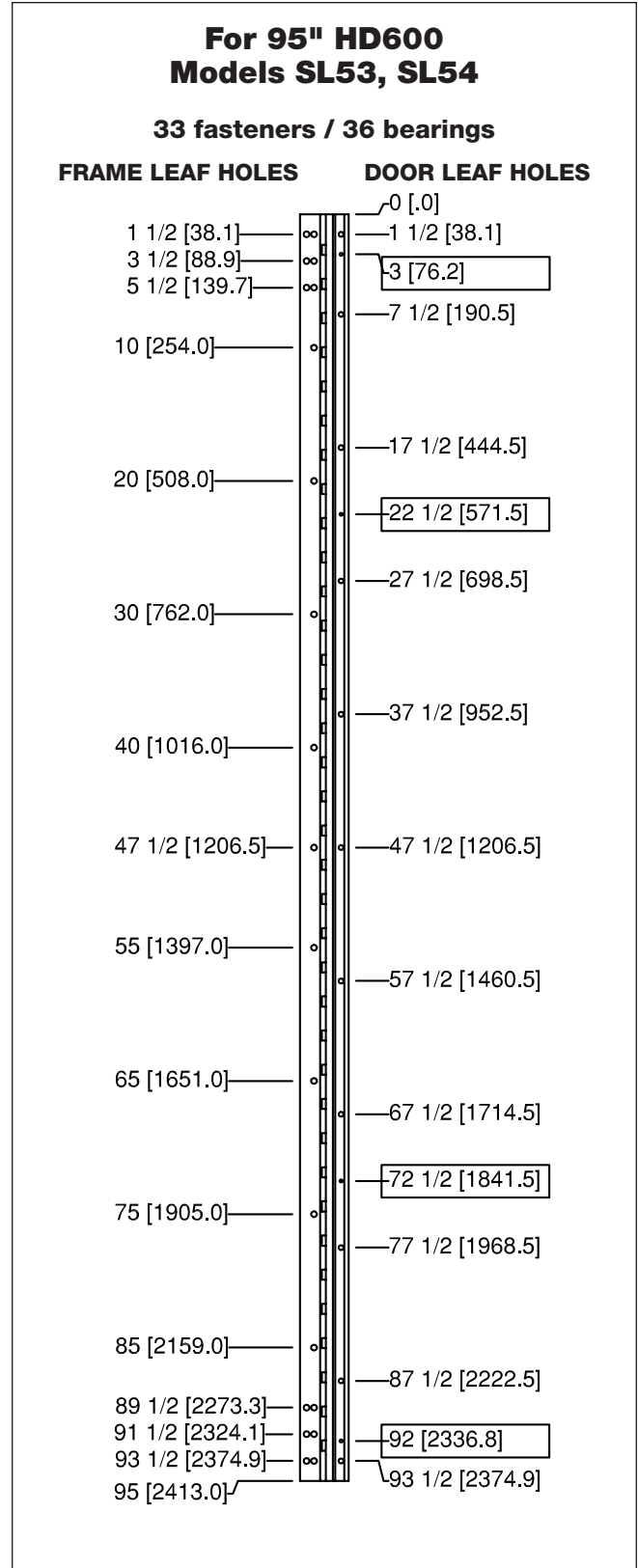
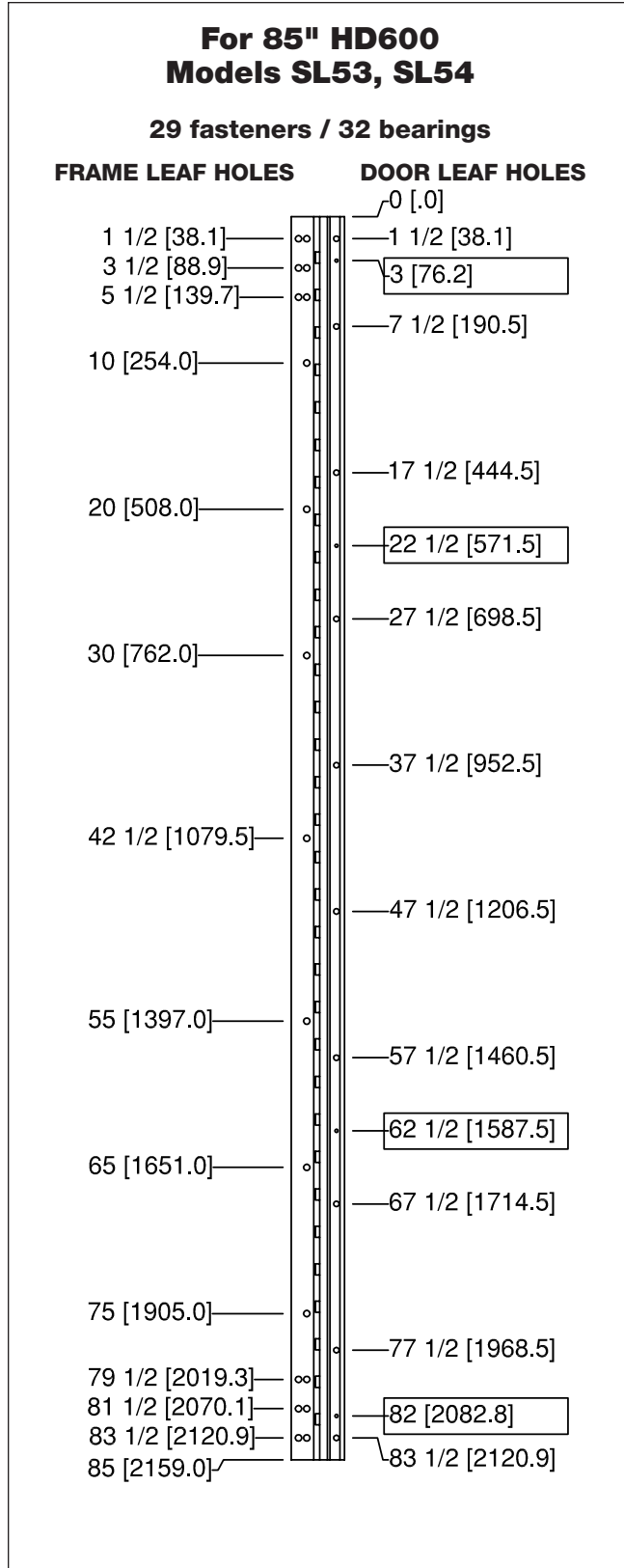


Half Surface Geared Hinges

- All dimensions are measured in inches and [millimeters] from the top of the door to the centerline of the holes.
- Dimensions shown inside boxes are locator screw mounting holes.

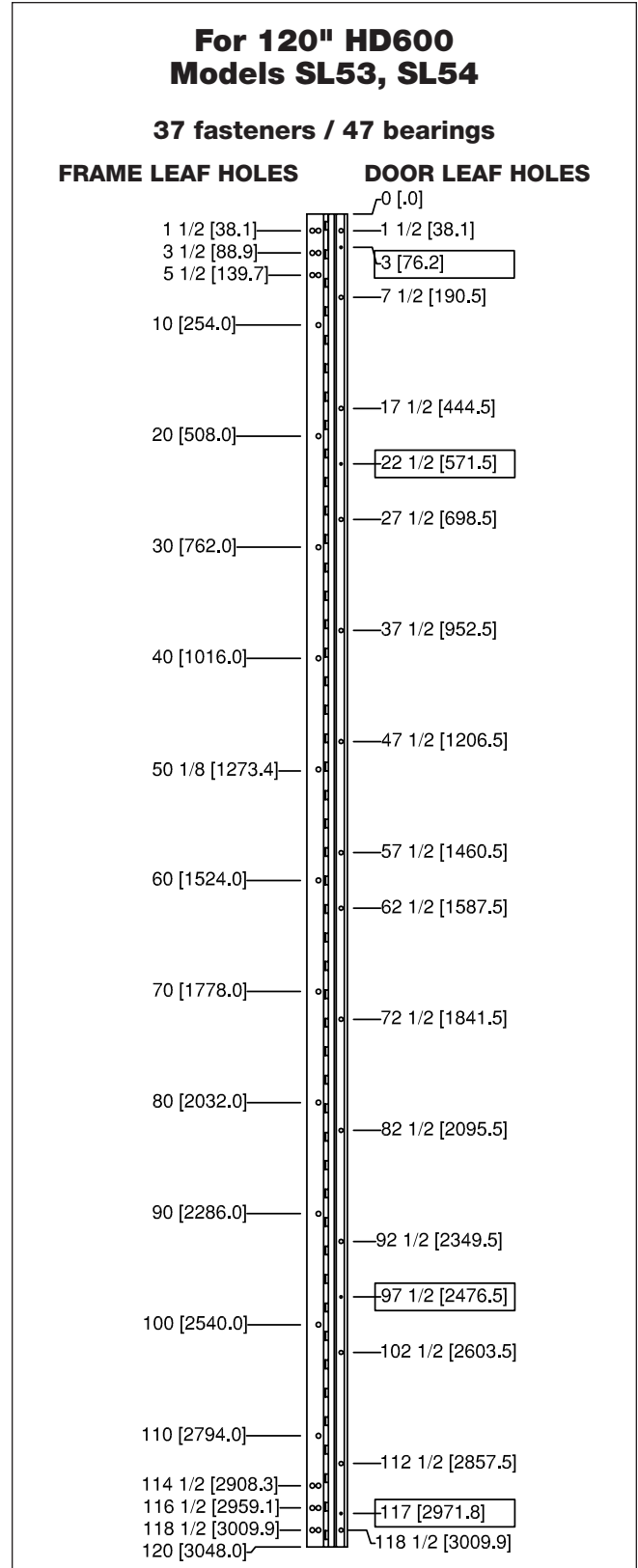
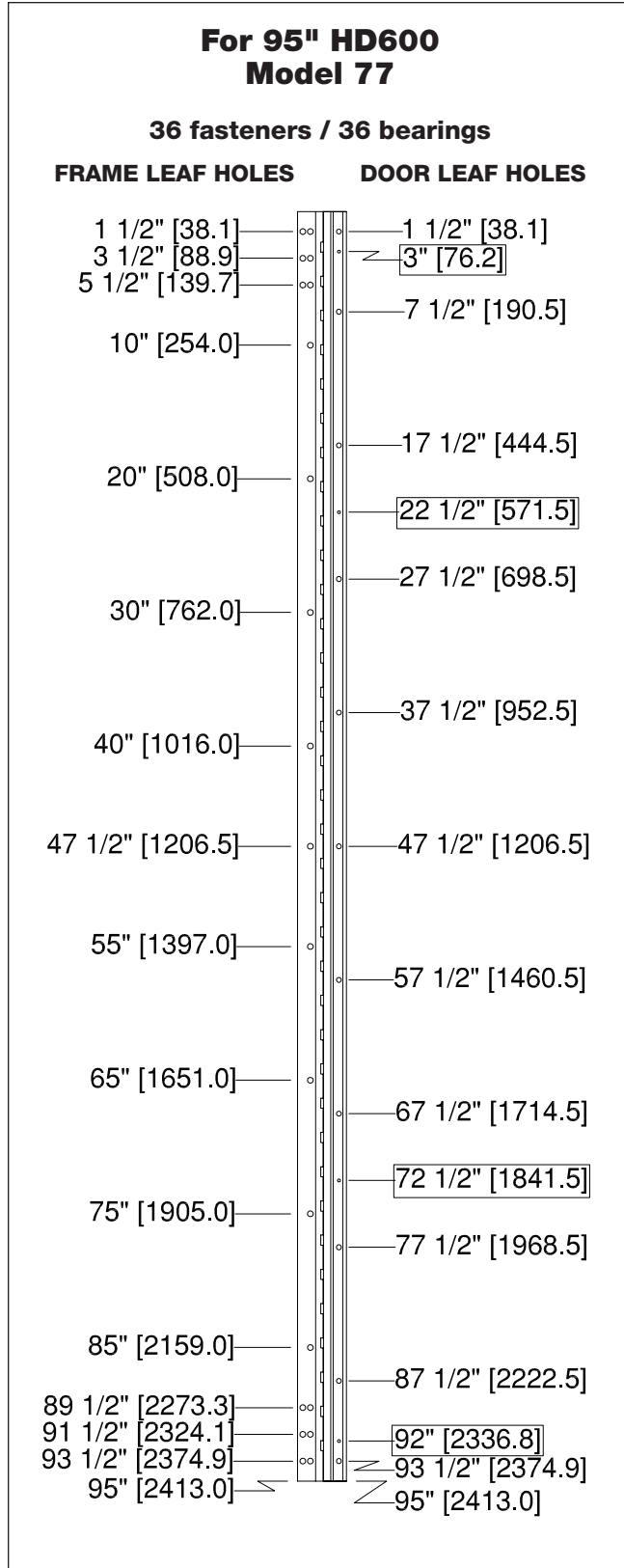


- All dimensions are measured in inches and [millimeters] from the top of the door to the centerline of the holes.
- Dimensions shown inside boxes are locator screw mounting holes.

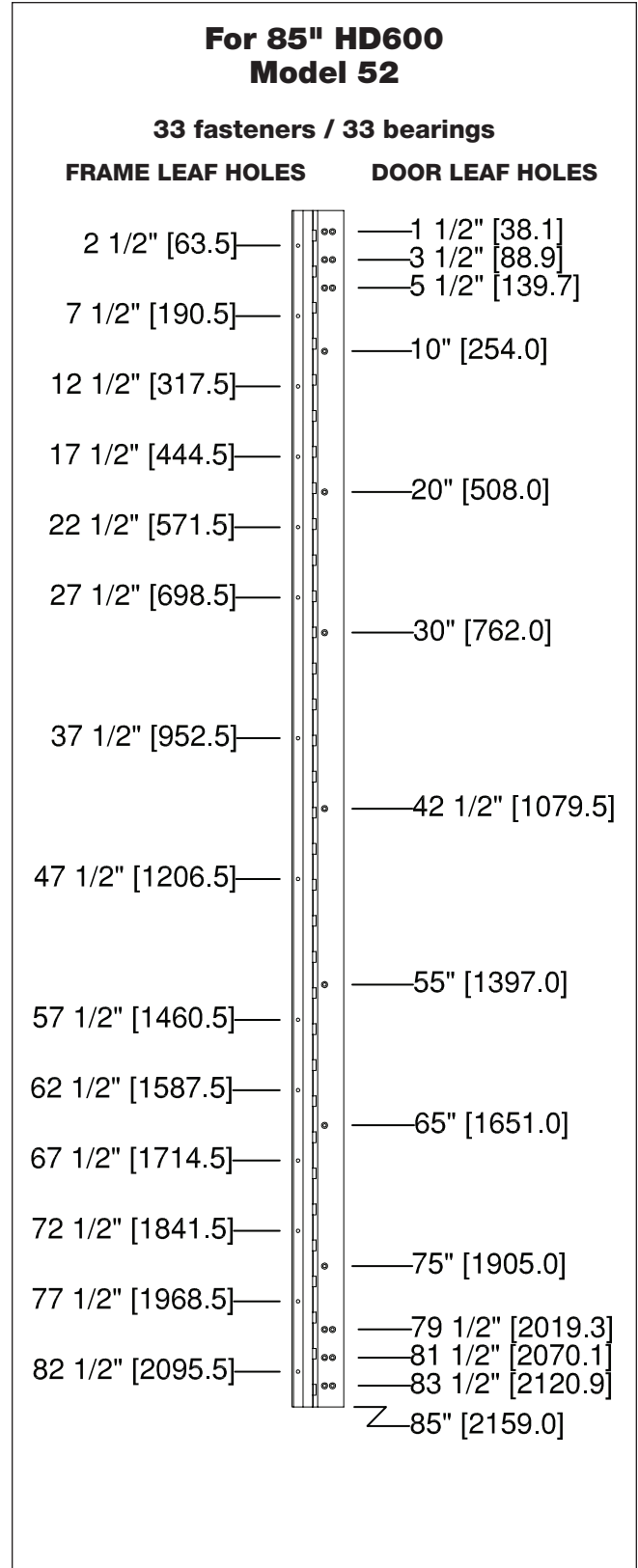
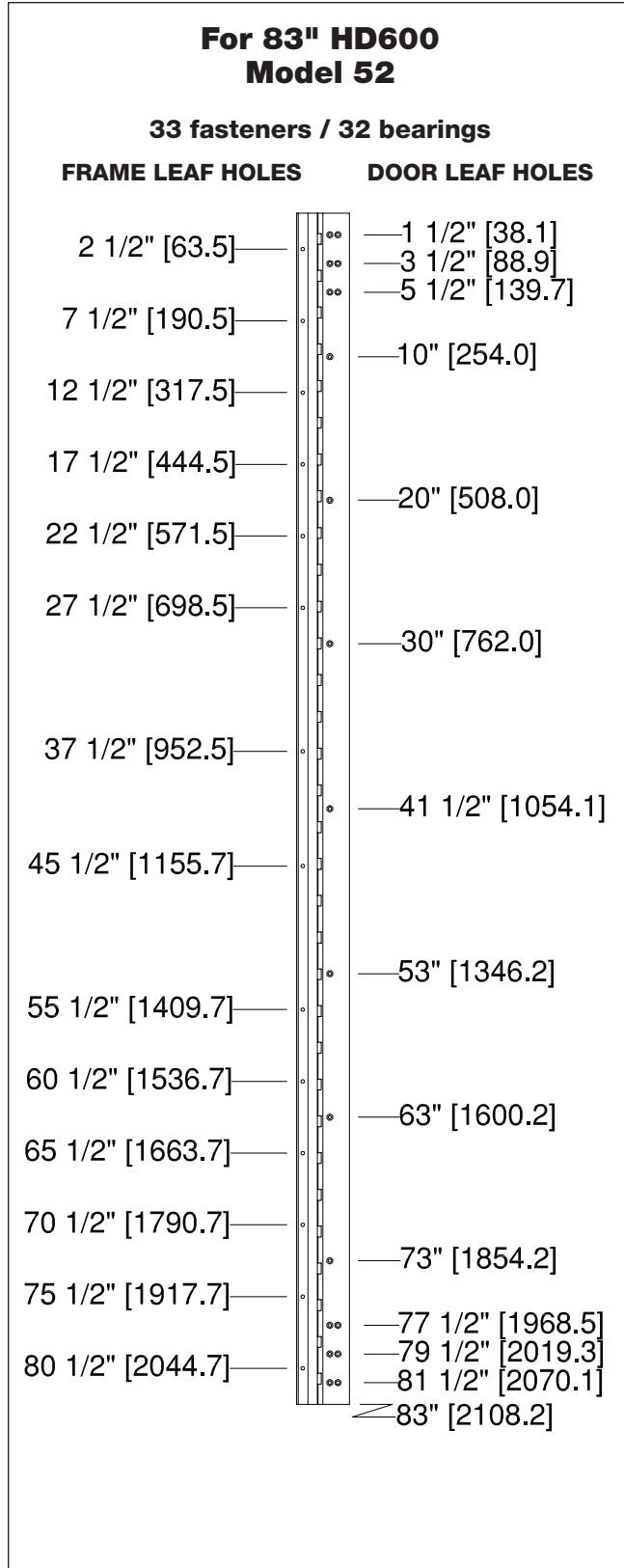


Half Surface Geared Hinges

- All dimensions are measured in inches and [millimeters] from the top of the door to the centerline of the holes.
- Dimensions shown inside boxes are locator screw mounting holes.

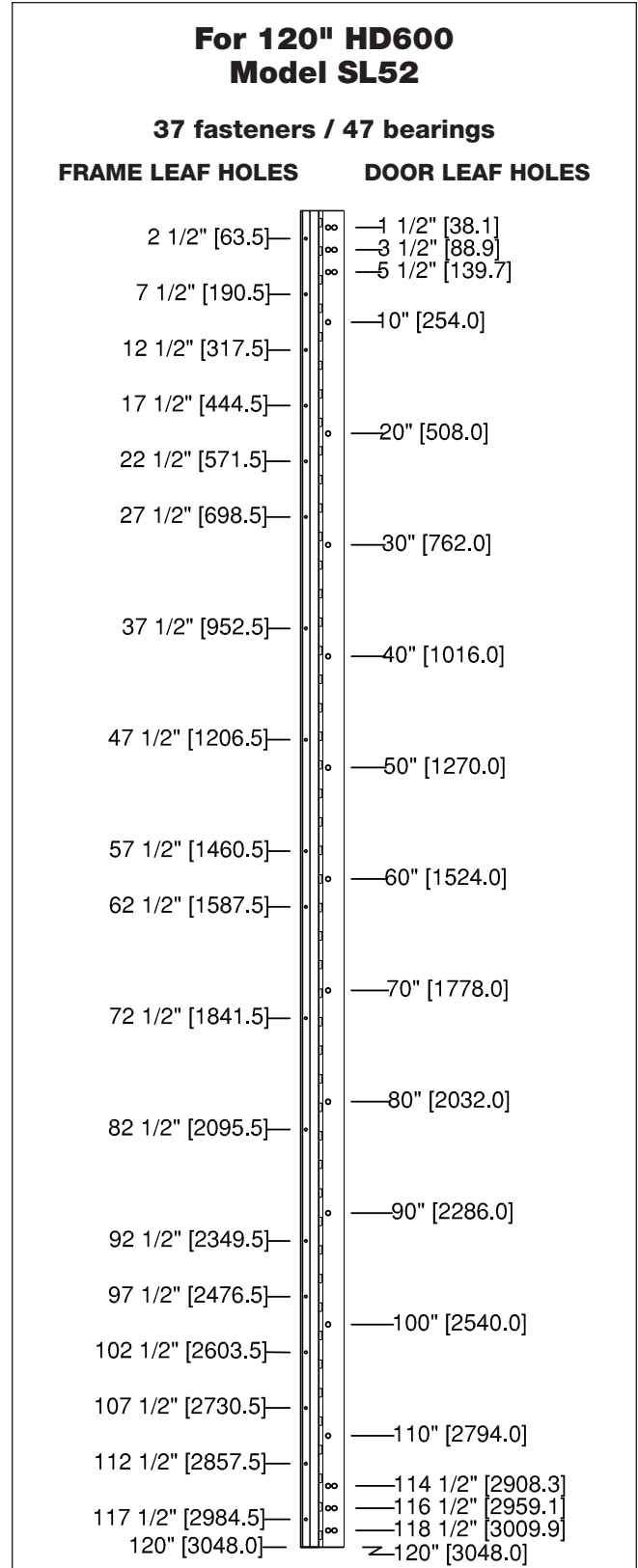
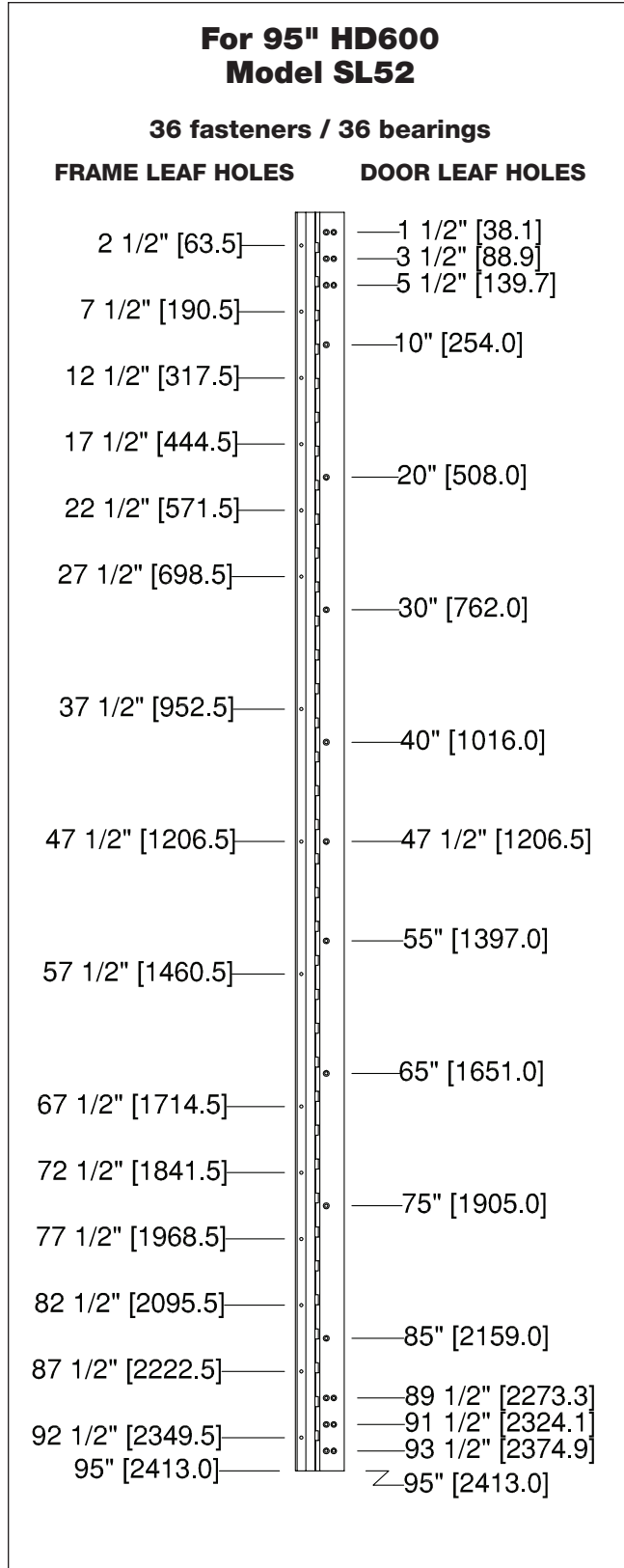


■ All dimensions are measured in inches and [millimeters] from the top of the door to the centerline of the holes.



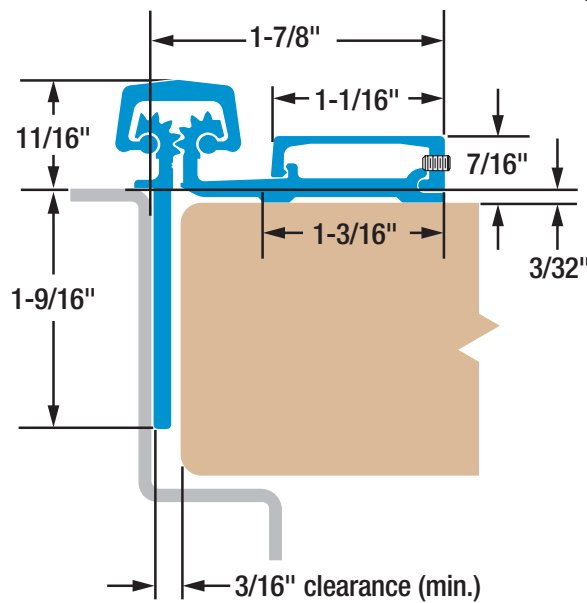
Half Mortise Geared Hinges

■ All dimensions are measured in inches and [millimeters] from the top of the door to the centerline of the holes.





- Narrow frame leaf
- Tamper-resistant, removable door leaf cover
- 3/32" door inset
- Standard barrel nuts accommodate 1-3/8" to 1-3/4" doors
- Long barrel nuts available for 2" to 2-1/4" doors



SL53

Half Surface Geared Continuous Hinge



Tested to last six decades



Reduce maintenance costs and hassles. Independent lab tests on an FRP door prove

SELECT hinges withstand 25 million cycles — more than 60 years of high-traffic use. Pair-Matched™ hinge leaves, lifetime lubrication and anodizing after machining deliver the longest life of any continuous hinge.

Covered by the only Continuous Warranty



Because SELECT geared continuous hinges have proven themselves in independent testing, we offer the industry's only Continuous Warranty. It

covers any failure of our aluminum geared continuous hinges — with no expiration date — as long as they are properly installed. Durability and worry-free performance ... guaranteed in writing. *The warranty that never ends for the hinge that never quits.SM*

Certified by U.S. Department of State



After brutal testing, the State Department granted a SELECT geared continuous hinge its 60-minute certification — the department's highest level. The hinge deflected bullets in the Ballistic Resistance Test and withstood sledgehammers,

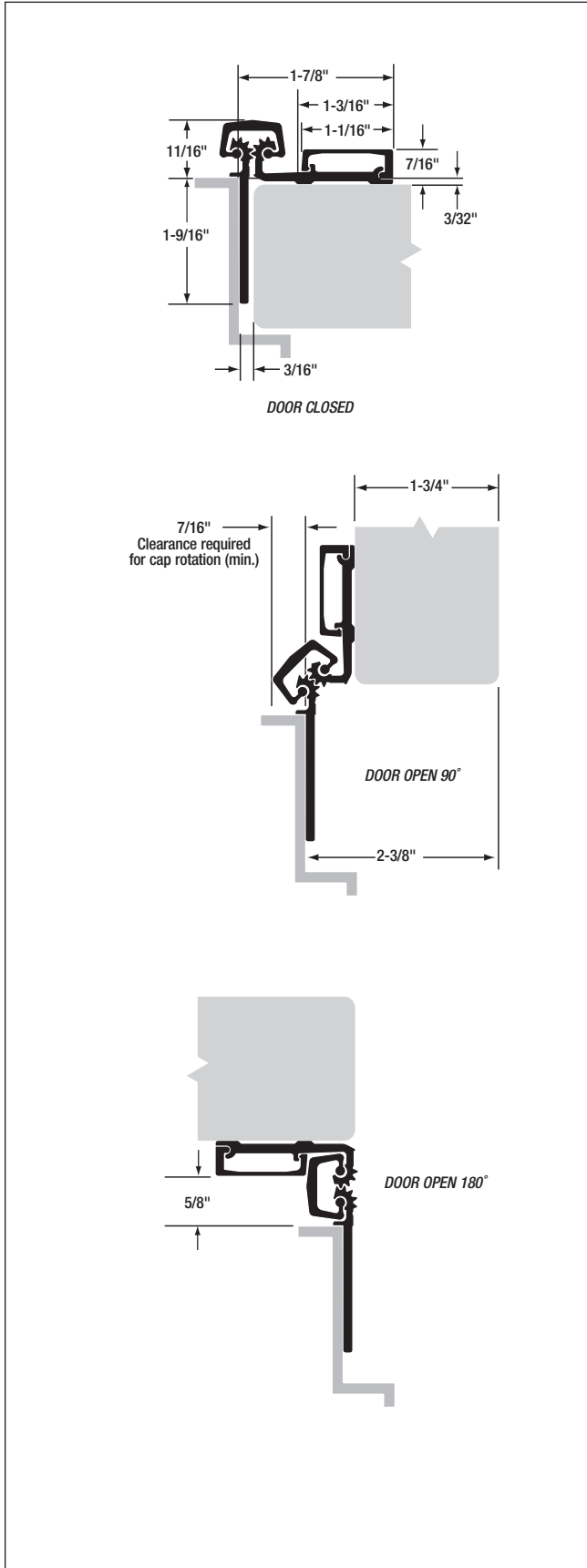
wedges and other tools in the Forced Entry Test. Approved for use in U.S. embassies overseas.

Geared to ship in 48 hours



SELECT ships hinges faster than anyone in the industry. 99.9% of our hinge orders ship in 48 hours; more than half are shipped in only 24 hours. Projects won't be delayed while waiting weeks for hinges.

NOTES:



MATERIAL: Extruded 6063 T6 aluminum alloy with self-lubricating polyester thrust bearings.

LENGTHS: 83", 85", 95" and 120" lengths standard for nominal door heights. Custom lengths are available.

LOAD/FREQUENCY RATINGS: For 1-3/8" – 1-3/4" doors standard; long barrel nuts available for 2" – 2-1/4" doors. 48" max. door width in 16 gauge hollow metal (min.) or 1/8" aluminum (min.).

Heavy Duty 600 – For high-frequency doors up to 600 lb. Rivnuts are recommended in the frame when the door exceeds 450 lb.

FINISHES: All SL53 hinges are stocked in Clear, Dark Bronze and Black anodized aluminum. Custom anodized or painted finishes are available. Product painted or anodized in the field voids the SELECT hinge warranty.

CLOSERS: Conventional overhead surface, concealed sliding arm overhead or floor closers may be used with SELECT hinges. Pivot-type floor closers (with a fixed, conflicting center pivot) must be replaced.

ORDER: Specify length, finish and heavy duty 600 (HD600). Also, specify door and frame screw applications. 12-24 x 3/4" self-drilling, thread-forming 410SS Phillips undercut flathead screws, 1/4-20 through-bolts and 1/4-20 shoulder screws (for doors up to 1-3/4" thick) are provided as a standard pack unless otherwise specified. Wood and thread-forming screws also available. Security screws optional at extra cost.

AVAILABLE ELECTRIC PREPS: EPT.



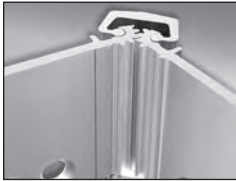
SL53 HINGE SCREW COUNT		
HINGE LENGTH & DUTY RATING	DOOR SCREWS	FRAME SCREWS
83" HD600	10	19
85" HD600	10	19
95" HD600	11	21
120" HD600	14	23

SELECT ADVANTAGES



PAIR-MATCHED™ HINGE LEAVES

Manufactured together, machined together and anodized together, making SELECT hinges fit your doors better and last longer. *An exclusive SELECT benefit.*



LIFETIME LUBRICATION

Eliminates the need for periodic maintenance. Quiet performance. Fights gear cap wear. *An exclusive SELECT benefit.*



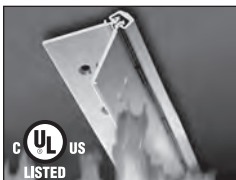
ANODIZED AFTER MACHINING

Delivers superior wear, durability and life. Inhibits corrosion. Few hinge makers follow SELECT's lead in using this superior manufacturing process.



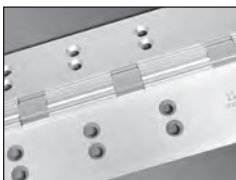
SUSTAINABLE

Made from up to 100% recycled aluminum. Reduces environmental impact and qualifies for LEED points. *An exclusive SELECT benefit.*



PATENTED 3-HR. FIRE RATING

Most SELECT hinges are fire rated for 90 minutes. 3-Hr. fire rating, optional at extra cost, approved for positive/negative pressure. No fire pins or studs required. Patented design innovation. *An exclusive SELECT benefit.*



CONSISTENT TEMPLATING

Hole pattern is identical on both Heavy Duty 300 and Heavy Duty 600 models, so SELECT hinges line up precisely for easier and faster installation. *An exclusive SELECT benefit.*



COATED FASTENERS

Provide additional corrosion protection with either self-drilling, thread-forming (SDTF) or thread-forming (TF) screws. *An exclusive SELECT benefit.*

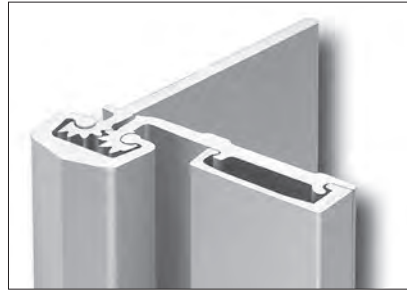


CUSTOM COLORS

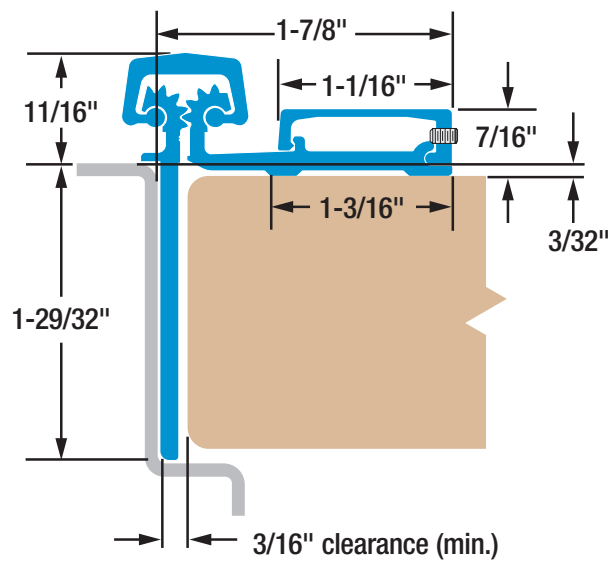
Match any paint color on the gear cap or the entire hinge and fasteners, including our always-in-stock Bone White gear caps. Anodized colors also available.

SELECT HINGE PERFORMANCE

- A SELECT geared continuous hinge has been tested in accordance with ANSI 250.4-1994 test procedure and acceptance criteria for physical endurance for steel doors and hardware and has surpassed 25,000,000 cycles during testing by an independent laboratory. On a door cycling 400,000 times per year, a SELECT hinge will be performing for over 62 years.
- SELECT geared continuous hinges are built to handle abuse from high-traffic applications. They are applied to the surface on the edge of the frame and door. No machining or reinforcement is required.
- The revolutionary SELECT geared continuous hinge puts an end to costly and irritating hinge failure problems, the most common cause of entrance failure.
- On conventional hinges, opening and “kick-back” energy concentrate on a few inches of fastened reinforcing plate — with the top hinge handling 100% of the force. Pinless SELECT hinges bond the door and frame into an integrated, sag-free unit. “Kick-back” energy dissipates along the entire length of the door and frame. (Compare this to a conventional hinge’s 4-1/2" to 5" at the top of the door and frame).
- SELECT geared continuous hinges eliminate the gap between the door and frame, providing a weatherproof, rust-proof, tamper-proof barrier. When the door is closed, there are no accessible screws, bolts or pins.
- SELECT SL53 geared continuous hinges are listed and tested by Underwriters Laboratories to meet the Positive and Negative pressure requirements of UL10B and UL10C, and are in accordance with UBC 7.2 (1997). SELECT SL53 geared continuous hinges are for use on swinging single fire doors (max. door opening of 4'x10') or pairs of fire doors (max. door opening of 8'x10'), including double egress, installed in masonry or drywall. SELECT SL53 geared continuous hinges are rated for up to 1-1/2 hours for wood composite and wood core type fire doors. A special patented process can be added to increase the fire rating to 3 hours (NO FIRE PINS OR STUDS REQUIRED) for hollow metal or steel covered composite type doors.



- Frame leaf covers butt hinge preps
- Tamper-resistant, removable door leaf cover
- 3/32" door inset
- Standard barrel nuts accommodate 1-3/8" to 1-3/4" doors
- Long barrel nuts available for 2" to 2-1/4" doors



SL54 Half Surface Geared Continuous Hinge



Tested to last six decades



Reduce maintenance costs and hassles. Independent lab tests on an FRP door prove

SELECT hinges withstand 25 million cycles — more than 60 years of high-traffic use. Pair-Matched™ hinge leaves, lifetime lubrication and anodizing after machining deliver the longest life of any continuous hinge.

Covered by the only Continuous Warranty



Because SELECT geared continuous hinges have proven themselves in independent testing, we offer the industry's only Continuous Warranty. It

covers any failure of our aluminum geared continuous hinges — with no expiration date — as long as they are properly installed. Durability and worry-free performance ... guaranteed in writing. *The warranty that never ends for the hinge that never quits.*SM

Certified by U.S. Department of State



After brutal testing, the State Department granted a SELECT geared continuous hinge its 60-minute certification — the department's highest level. The hinge deflected bullets in the Ballistic Resistance Test and withstood sledgehammers,

wedges and other tools in the Forced Entry Test. Approved for use in U.S. embassies overseas.

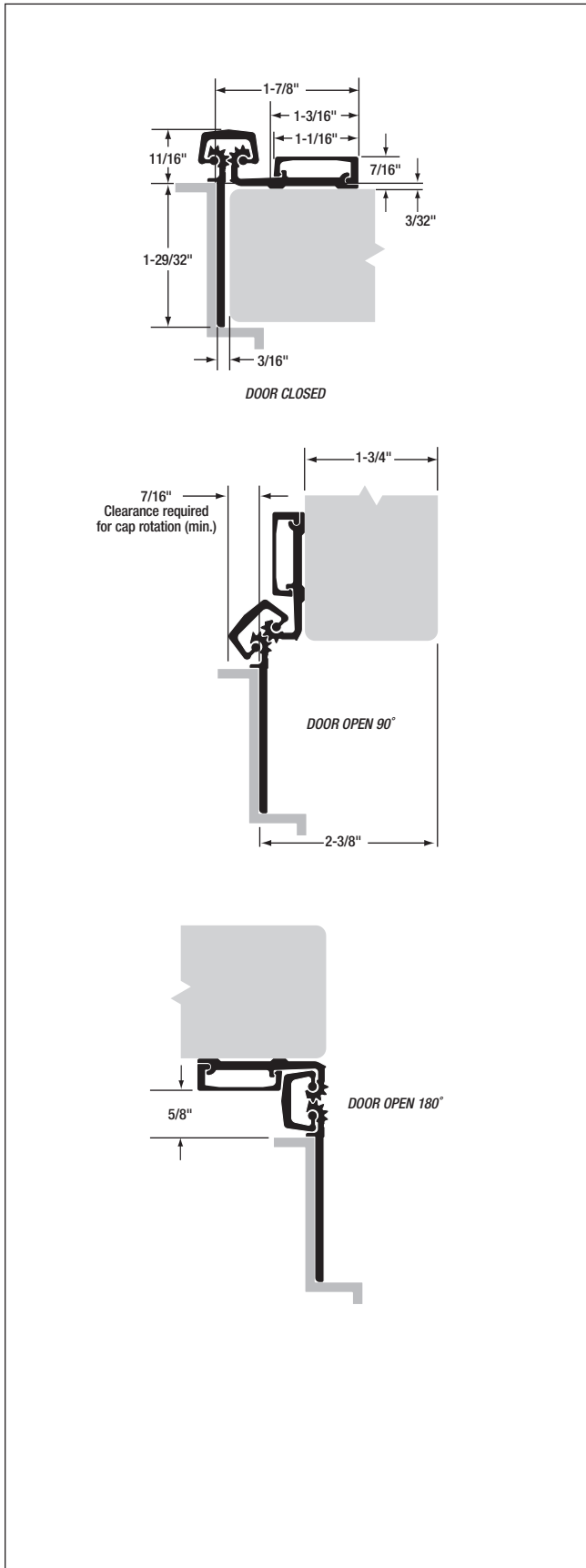
Geared to ship in 48 hours

Geared to ship in



SELECT ships hinges faster than anyone in the industry. 99.9% of our hinge orders ship in 48 hours; more than half are shipped in only 24 hours. Projects won't be delayed while waiting weeks for hinges.

NOTES:



MATERIAL: Extruded 6063 T6 aluminum alloy with self-lubricating polyester thrust bearings.

LENGTHS: 83", 85", 95" and 120" lengths standard for nominal door heights. Custom lengths are available.

LOAD/FREQUENCY RATINGS: For 1-3/8" – 1-3/4" doors standard; long barrel nuts available for 2" – 2-1/4" doors. 48" max. door width in 16 gauge hollow metal (min.) or 1/8" aluminum (min.).

Heavy Duty 600 – For high-frequency doors up to 600 lb. Rivnuts are recommended in the frame when the door exceeds 450 lb.

FINISHES: All SL54 hinges are stocked in Clear, Dark Bronze and Black anodized aluminum. Custom anodized or painted finishes are available. Product painted or anodized in the field voids the SELECT hinge warranty.

CLOSERS: Conventional overhead surface, concealed sliding arm overhead or floor closers may be used with SELECT hinges. Pivot-type floor closers (with a fixed, conflicting center pivot) must be replaced.

ORDER: Specify length, finish and heavy duty 600 (HD600). Also, specify door and frame screw applications. 12-24 x 3/4" self-drilling, thread-forming 410SS Phillips undercut flathead screws, 1/4-20 through-bolts and 1/4-20 shoulder screws (for doors up to 1-3/4" thick) are provided as a standard pack unless otherwise specified. Wood and thread-forming screws also available. Security screws optional at extra cost.

AVAILABLE ELECTRIC PREPS: EPT.



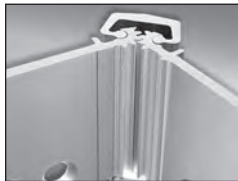
SL54 HINGE SCREW COUNT		
HINGE LENGTH & DUTY RATING	DOOR SCREWS	FRAME SCREWS
83" HD600	10	19
85" HD600	10	19
95" HD600	11	21
120" HD600	14	23

SELECT ADVANTAGES



PAIR-MATCHED™ HINGE LEAVES

Manufactured together, machined together and anodized together, making SELECT hinges fit your doors better and last longer. *An exclusive SELECT benefit.*



LIFETIME LUBRICATION

Eliminates the need for periodic maintenance. Quiet performance. Fights gear cap wear. *An exclusive SELECT benefit.*



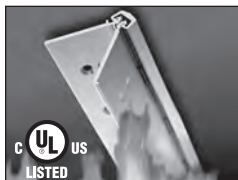
ANODIZED AFTER MACHINING

Delivers superior wear, durability and life. Inhibits corrosion. Few hinge makers follow SELECT's lead in using this superior manufacturing process.



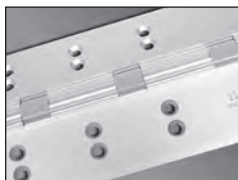
SUSTAINABLE

Made from up to 100% recycled aluminum. Reduces environmental impact and qualifies for LEED points. *An exclusive SELECT benefit.*



PATENTED 3-HR. FIRE RATING

Most SELECT hinges are fire rated for 90 minutes. 3-Hr. fire rating, optional at extra cost, approved for positive/negative pressure. No fire pins or studs required. Patented design innovation. *An exclusive SELECT benefit.*



CONSISTENT TEMPLATING

Hole pattern is identical on both Heavy Duty 300 and Heavy Duty 600 models, so SELECT hinges line up precisely for easier and faster installation. *An exclusive SELECT benefit.*



COATED FASTENERS

Provide additional corrosion protection with either self-drilling, thread-forming (SDTF) or thread-forming (TF) screws. *An exclusive SELECT benefit.*

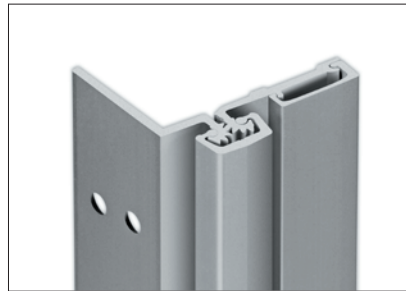


CUSTOM COLORS

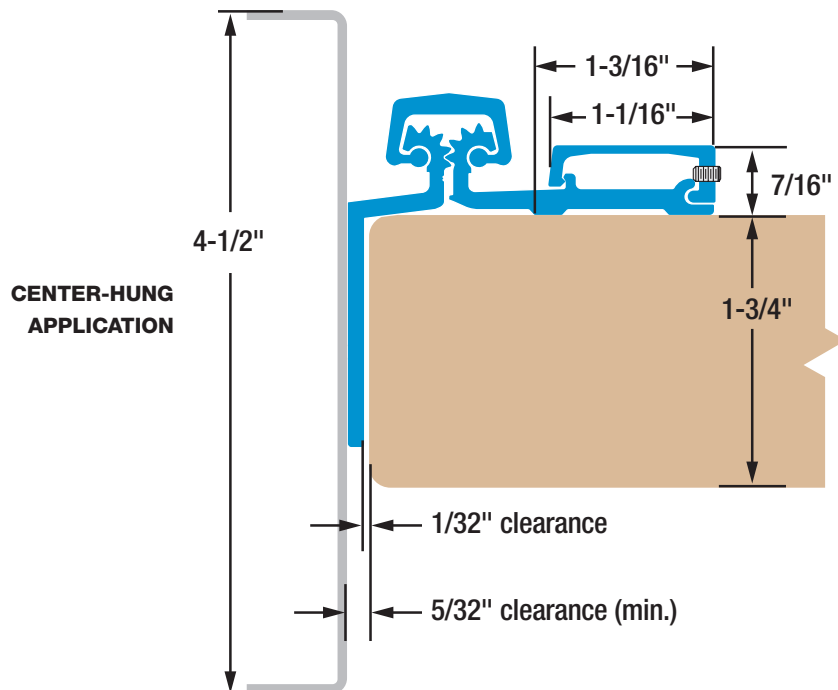
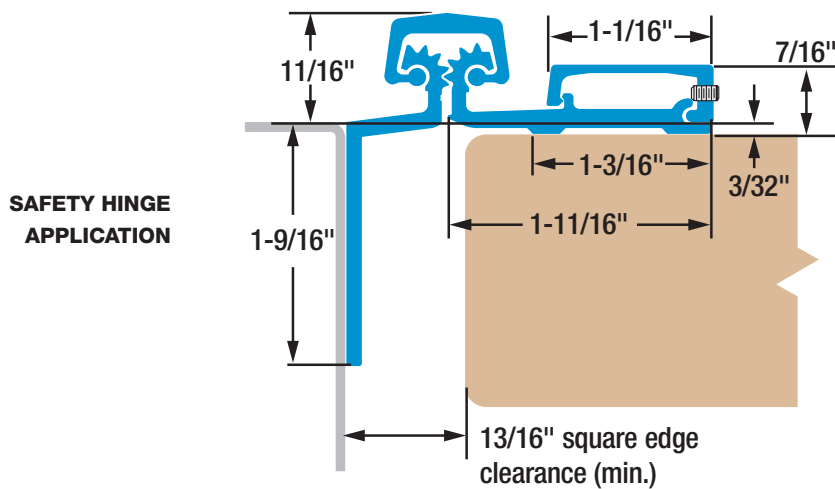
Match any paint color on the gear cap or the entire hinge and fasteners, including our always-in-stock Bone White gear caps. Anodized colors also available.

SELECT HINGE PERFORMANCE

- A SELECT geared continuous hinge has been tested in accordance with ANSI 250.4-1994 test procedure and acceptance criteria for physical endurance for steel doors and hardware and has surpassed 25,000,000 cycles during testing by an independent laboratory. On a door cycling 400,000 times per year, a SELECT hinge will be performing for over 62 years.
- SELECT geared continuous hinges are built to handle abuse from high-traffic applications. They are applied to the surface on the edge of the frame and door. No machining or reinforcement is required.
- The revolutionary SELECT geared continuous hinge puts an end to costly and irritating hinge failure problems, the most common cause of entrance failure.
- On conventional hinges, opening and “kick-back” energy concentrate on a few inches of fastened reinforcing plate — with the top hinge handling 100% of the force. Pinless SELECT hinges bond the door and frame into an integrated, sag-free unit. “Kick-back” energy dissipates along the entire length of the door and frame. (Compare this to a conventional hinge’s 4-1/2" to 5" at the top of the door and frame).
- SELECT geared continuous hinges eliminate the gap between the door and frame, providing a weatherproof, rust-proof, tamper-proof barrier. When the door is closed, there are no accessible screws, bolts or pins.
- SELECT SL54 geared continuous hinges are listed and tested by Underwriters Laboratories to meet the Positive and Negative pressure requirements of UL10B and UL10C, and are in accordance with UBC 7.2 (1997). SELECT SL54 geared continuous hinges are for use on swinging single fire doors (max. door opening of 4'x10') or pairs of fire doors (max. door opening of 8'x10'), including double egress, installed in masonry or drywall. SELECT SL54 geared continuous hinges are rated for up to 1-1/2 hours for wood composite and wood core type fire doors. A special patented process can be added to increase the fire rating to 3 hours (NO FIRE PINS OR STUDS REQUIRED) for hollow metal or steel covered composite type doors.



- Safety hinge (when used without frame stop)
- Can be used in center-hung application
- Provides clearance sufficient to avoid the pinching of fingers
- Tamper-resistant, removable door leaf cover
- Can be used for center-hung applications (without safety feature)
- 3/32" door inset when used as a safety hinge
- Standard barrel nuts accommodate 1-3/8" to 1-3/4" doors
- Long barrel nuts available for 2" to 2-1/4" doors



SL77

Half Surface Geared Continuous Hinge



Tested to last six decades



Reduce maintenance costs and hassles. Independent lab tests on an FRP door prove

SELECT hinges withstand 25 million cycles — more than 60 years of high-traffic use. Pair-Matched™ hinge leaves, lifetime lubrication and anodizing after machining deliver the longest life of any continuous hinge.

Covered by the only Continuous Warranty



Because SELECT geared continuous hinges have proven themselves in independent testing, we offer the industry's only Continuous Warranty. It

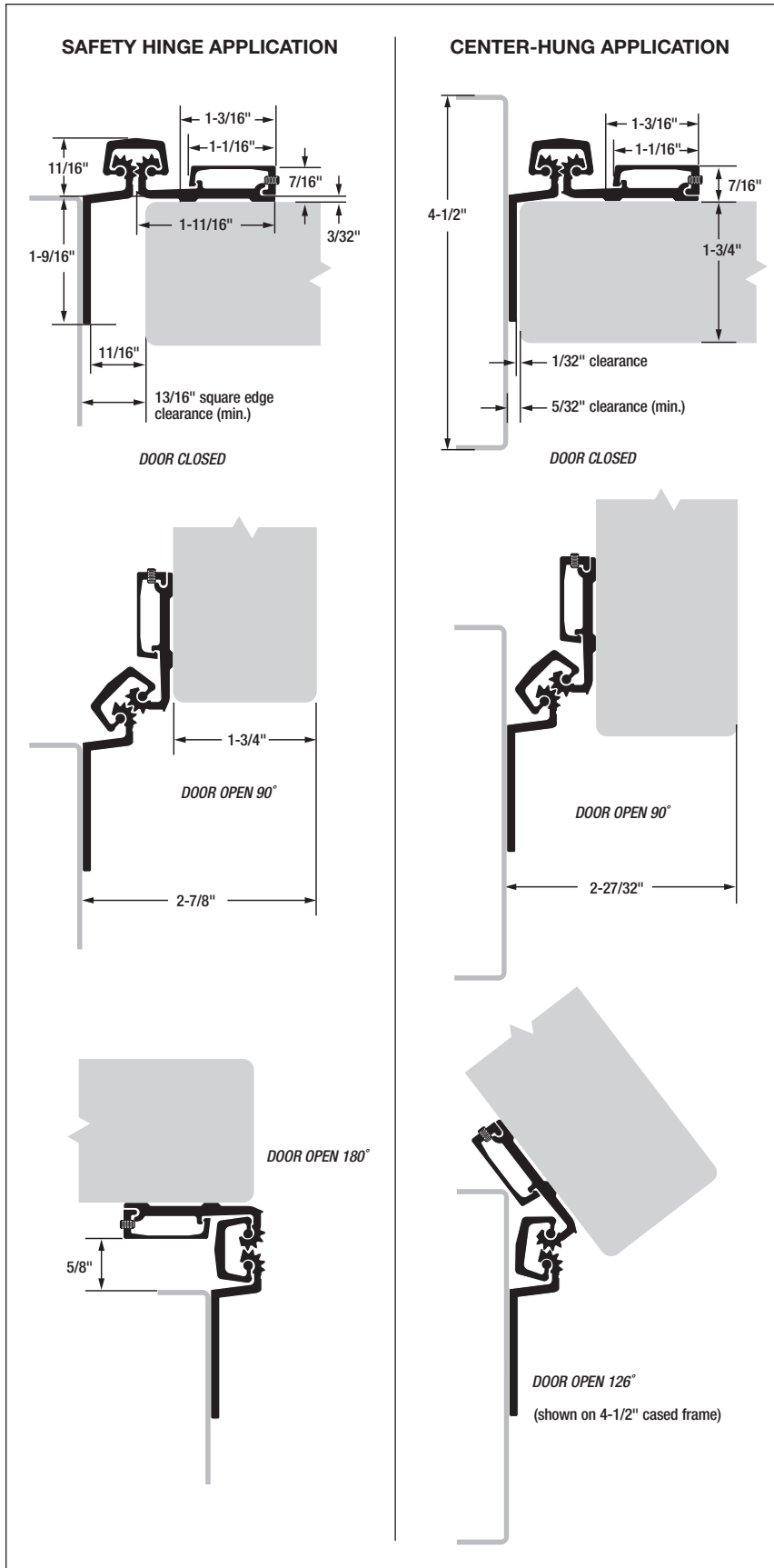
covers any failure of our aluminum geared continuous hinges — with no expiration date — as long as they are properly installed. Durability and worry-free performance ... guaranteed in writing. *The warranty that never ends for the hinge that never quits.SM*

Geared to ship in 48 hours



SELECT ships hinges faster than anyone in the industry. 99.9% of our hinge orders ship in 48 hours; more than half are shipped in only 24 hours. Projects won't be delayed while waiting weeks for hinges.

NOTES:



MATERIAL: Extruded 6063 T6 aluminum alloy with self-lubricating polyester thrust bearings.

LENGTHS: 83" and 95" lengths standard for nominal door heights. Custom lengths are available.

LOAD/FREQUENCY RATINGS:
 For 1-3/8" – 1-3/4" doors standard; long barrel nuts available for 2" – 2-1/4" doors. 48" max. door width in 16 gauge hollow metal (min.) or 1/8" aluminum (min.).

Heavy Duty 600 – For high-frequency doors up to 600 lb. Rivnuts are recommended in the frame when the door exceeds 450 lb.

FINISHES: All SL77 hinges are stocked in Clear and Dark Bronze anodized aluminum. Custom anodized or painted finishes are available. Product painted or anodized in the field voids the SELECT hinge warranty.

CLOSERS: Conventional overhead surface, concealed sliding arm overhead or floor closers may be used with SELECT hinges. Pivot-type floor closers (with a fixed, conflicting center pivot) must be replaced.

ORDER: Specify length, finish and heavy duty 600 (HD600). Also, specify door and frame screw applications. 12-24 x 3/4" self-drilling, thread-forming 410SS Phillips undercut flathead screws, 1/4-20 through-bolts and 1/4-20 shoulder screws (for doors up to 1-3/4" thick) are provided as a standard pack unless otherwise specified. Wood and thread-forming screws also available. Security screws optional at extra cost.

AVAILABLE ELECTRIC PREP: EPT.



SL77 HINGE SCREW COUNT

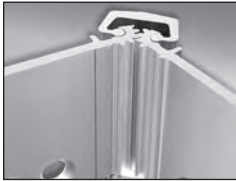
HINGE LENGTH & DUTY RATING	DOOR SCREWS	FRAME SCREWS
83" HD600	10	14
95" HD600	11	15

SELECT ADVANTAGES



PAIR-MATCHED™ HINGE LEAVES

Manufactured together, machined together and anodized together, making SELECT hinges fit your doors better and last longer.
An exclusive SELECT benefit.



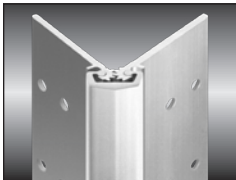
LIFETIME LUBRICATION

Eliminates the need for periodic maintenance. Quiet performance. Fights gear cap wear.
An exclusive SELECT benefit.



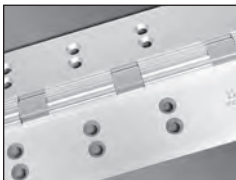
ANODIZED AFTER MACHINING

Delivers superior wear, durability and life. Inhibits corrosion. Few hinge makers follow SELECT's lead in using this superior manufacturing process.



SUSTAINABLE

Made from up to 100% recycled aluminum. Reduces environmental impact and qualifies for LEED points.
An exclusive SELECT benefit.



CONSISTENT TEMPLATING

Hole pattern is identical on both Heavy Duty 300 and Heavy Duty 600 models, so SELECT hinges line up precisely for easier and faster installation.
An exclusive SELECT benefit.



COATED FASTENERS

Provide additional corrosion protection with either self-drilling, thread-forming (SDTF) or thread-forming (TF) screws.
An exclusive SELECT benefit.

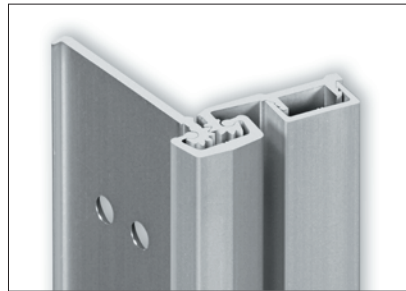


CUSTOM COLORS

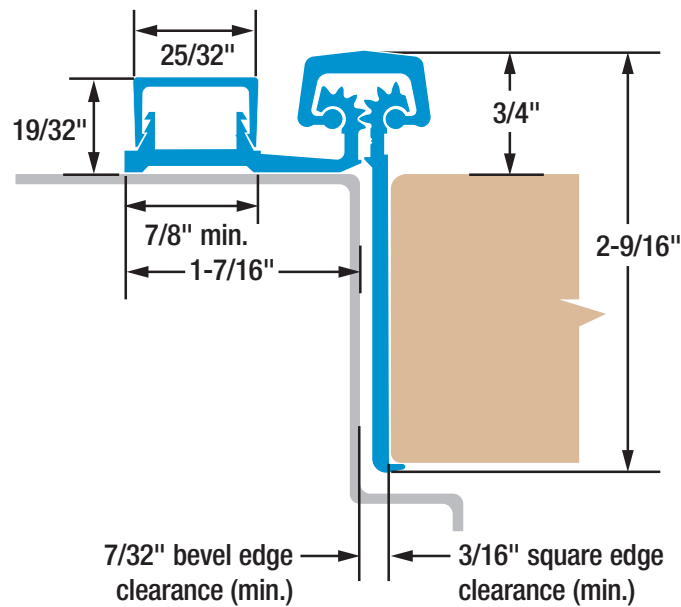
Match any paint color on the gear cap or the entire hinge and fasteners, including our always-in-stock Bone White gear caps. Anodized colors also available.

SELECT HINGE PERFORMANCE

- A SELECT geared continuous hinge has been tested in accordance with ANSI 250.4-1994 test procedure and acceptance criteria for physical endurance for steel doors and hardware and has surpassed 25,000,000 cycles during testing by an independent laboratory. On a door cycling 400,000 times per year, a SELECT hinge will be performing for over 62 years.
- SELECT geared continuous hinges are built to handle abuse from high-traffic applications. They are applied to the surface on the edge of the frame and door. No machining or reinforcement is required.
- The revolutionary SELECT geared continuous hinge puts an end to costly and irritating hinge failure problems, the most common cause of entrance failure.
- On conventional hinges, opening and “kick-back” energy concentrate on a few inches of fastened reinforcing plate — with the top hinge handling 100% of the force. Pinless SELECT hinges bond the door and frame into an integrated, sag-free unit. “Kick-back” energy dissipates along the entire length of the door and frame. (Compare this to a conventional hinge’s 4-1/2" to 5" at the top of the door and frame).
- SELECT geared continuous hinges eliminate the gap between the door and frame, providing a weatherproof, rust-proof, tamper-proof barrier. When the door is closed, there are no accessible screws, bolts or pins.



- Frame leaf fits narrow (7/8") frame face
- Tamper-resistant, removable frame leaf cover
- Door edge protector
- Flush mounted (no door inset)
- For 1-3/4" doors



SL52 Half Mortise Geared Continuous Hinge



Tested to last six decades



Reduce maintenance costs and hassles. Independent lab tests on an FRP door prove

SELECT hinges withstand 25 million cycles — more than 60 years of high-traffic use. Pair-Matched™ hinge leaves, lifetime lubrication and anodizing after machining deliver the longest life of any continuous hinge.

Covered by the only Continuous Warranty



Because SELECT geared continuous hinges have proven themselves in independent testing, we offer the industry's only Continuous Warranty. It

covers any failure of our aluminum geared continuous hinges — with no expiration date — as long as they are properly installed. Durability and worry-free performance ... guaranteed in writing. *The warranty that never ends for the hinge that never quits.*SM

Certified by U.S. Department of State



After brutal testing, the State Department granted a SELECT geared continuous hinge its 60-minute certification — the department's highest level. The hinge deflected bullets in the Ballistic Resistance Test and withstood sledgehammers,

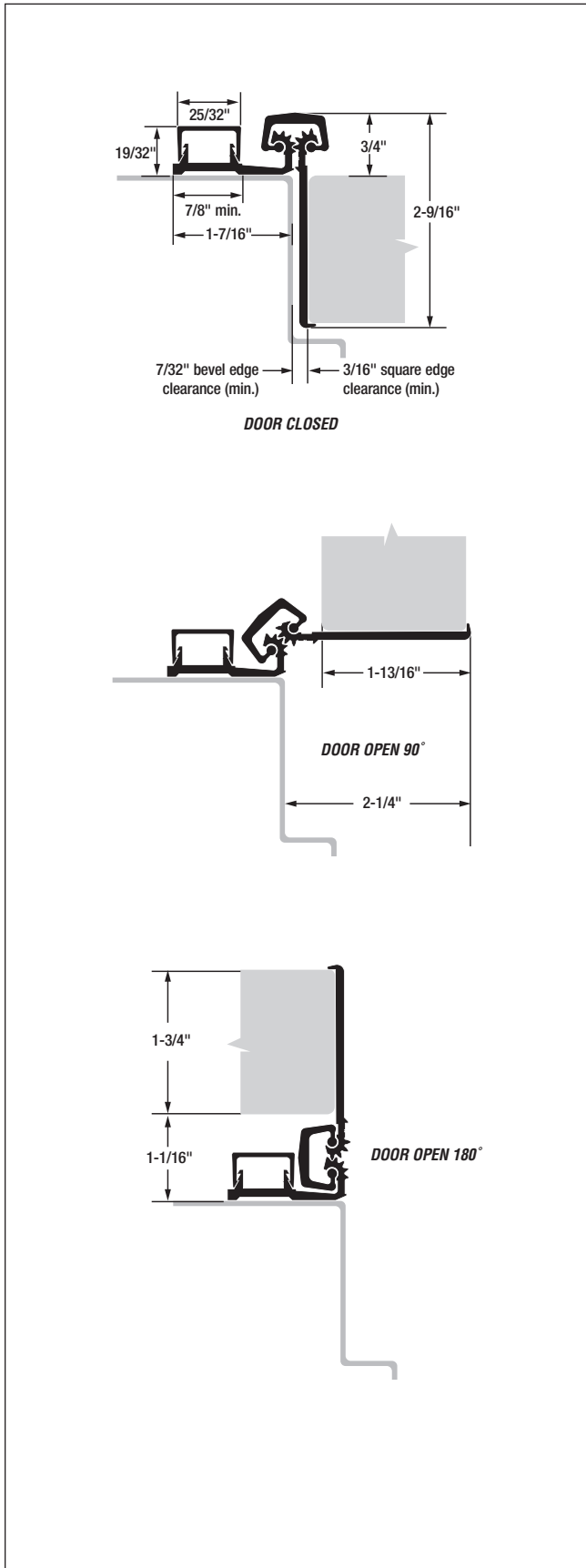
wedges and other tools in the Forced Entry Test. Approved for use in U.S. embassies overseas.

Geared to ship in 48 hours



SELECT ships hinges faster than anyone in the industry. 99.9% of our hinge orders ship in 48 hours; more than half are shipped in only 24 hours. Projects won't be delayed while waiting weeks for hinges.

NOTES:



MATERIAL: Extruded 6063 T6 aluminum alloy with self-lubricating polyester thrust bearings.

LENGTHS: 83" and 95" lengths standard for nominal door heights. Custom lengths are available.

LOAD/FREQUENCY RATINGS: For 1-3/4" doors. 48" max. door width in 16 gauge hollow metal (min.) or 1/8" aluminum (min.).

Heavy Duty 600 – For high-frequency doors up to 600 lb. Rivnuts are recommended in the door when the door exceeds 450 lb.

FINISHES: All SL52 hinges are stocked in Clear and Dark Bronze anodized aluminum. Custom anodized or painted finishes are available. Product painted or anodized in the field voids the SELECT hinge warranty.

CLOSERS: Conventional overhead surface, concealed sliding arm overhead or floor closers may be used with SELECT hinges. Pivot-type floor closers (with a fixed, conflicting center pivot) must be replaced.

ORDER: Specify length, finish and heavy duty 600 (HD600). Also, specify door and frame screw applications. 12-24 x 3/4" self-drilling, thread-forming 410SS Phillips undercut flathead screws are provided as a standard pack unless otherwise specified. Wood and thread-forming screws also available. Security screws optional at extra cost.

AVAILABLE ELECTRIC PREPS: EPT.



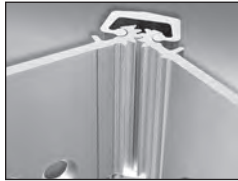
SL52 HINGE SCREW COUNT		
HINGE LENGTH & DUTY RATING	DOOR SCREWS	FRAME SCREWS
83" HD600	19	14
95" HD600	21	15

SELECT ADVANTAGES



PAIR-MATCHED™ HINGE LEAVES

Manufactured together, machined together and anodized together, making SELECT hinges fit your doors better and last longer. *An exclusive SELECT benefit.*



LIFETIME LUBRICATION

Eliminates the need for periodic maintenance. Quiet performance. Fights gear cap wear. *An exclusive SELECT benefit.*



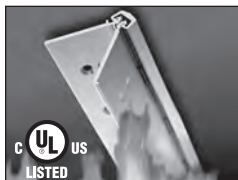
ANODIZED AFTER MACHINING

Delivers superior wear, durability and life. Inhibits corrosion. Few hinge makers follow SELECT's lead in using this superior manufacturing process.



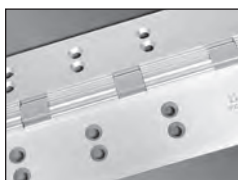
SUSTAINABLE

Made from up to 100% recycled aluminum. Reduces environmental impact and qualifies for LEED points. *An exclusive SELECT benefit.*



PATENTED 3-HR. FIRE RATING

Most SELECT hinges are fire rated for 90 minutes. 3-Hr. fire rating, optional at extra cost, approved for positive/negative pressure. No fire pins or studs required. Patented design innovation. *An exclusive SELECT benefit.*



CONSISTENT TEMPLATING

Hole pattern is identical on both Heavy Duty 300 and Heavy Duty 600 models, so SELECT hinges line up precisely for easier and faster installation. *An exclusive SELECT benefit.*



COATED FASTENERS

Provide additional corrosion protection with either self-drilling, thread-forming (SDTF) or thread-forming (TF) screws. *An exclusive SELECT benefit.*



CUSTOM COLORS

Match any paint color on the gear cap or the entire hinge and fasteners, including our always-in-stock Bone White gear caps. Anodized colors also available.

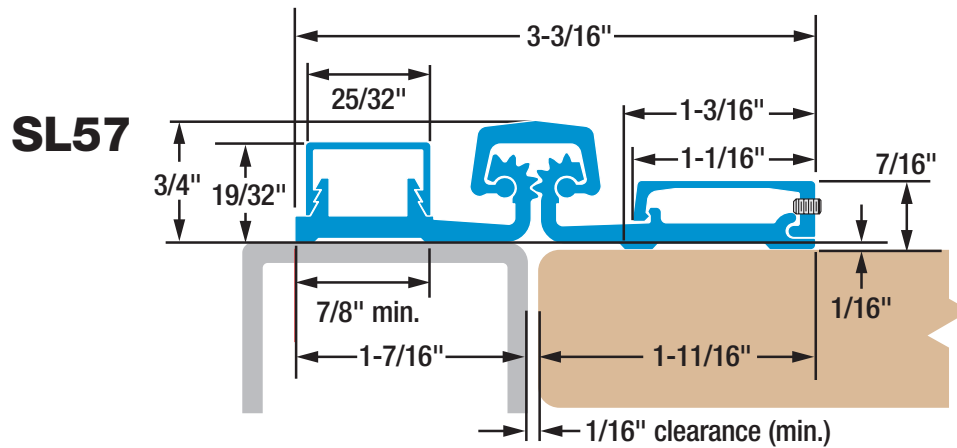
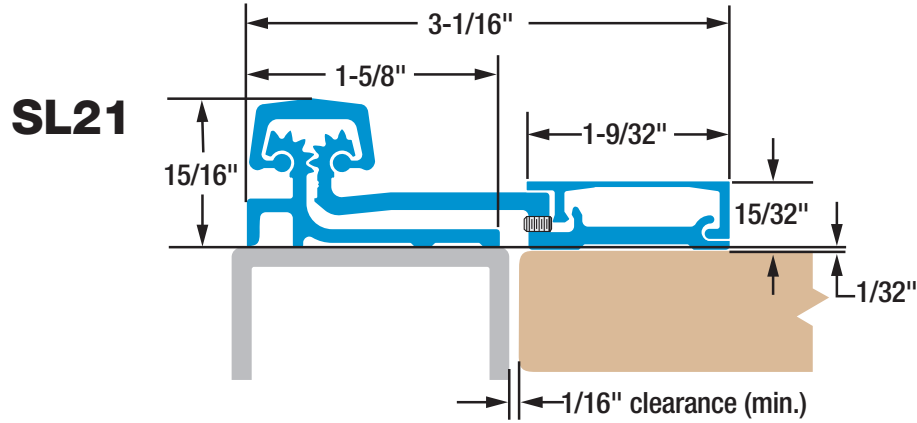
SELECT HINGE PERFORMANCE

- A SELECT geared continuous hinge has been tested in accordance with ANSI 250.4-1994 test procedure and acceptance criteria for physical endurance for steel doors and hardware and has surpassed 25,000,000 cycles during testing by an independent laboratory. On a door cycling 400,000 times per year, a SELECT hinge will be performing for over 62 years.
- SELECT geared continuous hinges are built to handle abuse from high-traffic applications. They are applied to the surface on the edge of the frame and door. No machining or reinforcement is required.
- The revolutionary SELECT geared continuous hinge puts an end to costly and irritating hinge failure problems, the most common cause of entrance failure.
- On conventional hinges, opening and “kick-back” energy concentrate on a few inches of fastened reinforcing plate — with the top hinge handling 100% of the force. Pinless SELECT hinges bond the door and frame into an integrated, sag-free unit. “Kick-back” energy dissipates along the entire length of the door and frame. (Compare this to a conventional hinge’s 4-1/2" to 5" at the top of the door and frame).
- SELECT geared continuous hinges eliminate the gap between the door and frame, providing a weatherproof, rust-proof, tamper-proof barrier. When the door is closed, there are no accessible screws, bolts or pins.
- SELECT SL52 geared continuous hinges are listed and tested by Underwriters Laboratories to meet the Positive and Negative pressure requirements of UL10B and UL10C, and are in accordance with UBC 7.2 (1997). SELECT SL52 geared continuous hinges are for use on swinging single fire doors (max. door opening of 4'x10') or pairs of fire doors (max. door opening of 8'x10'), including double egress, installed in masonry or drywall. SELECT SL52 geared continuous hinges are rated for up to 1-1/2 hours for wood composite and wood core type fire doors. A special patented process can be added to increase the fire rating to 3 hours (NO FIRE PINS OR STUDS REQUIRED) for hollow metal or steel covered composite type doors.



**SELECT
HINGES®**

FULL SURFACE GEARED CONTINUOUS HINGES



FULL SURFACE

FULL SURFACE GEARED CONTINUOUS HINGES



PART NUMBER INTERCHANGE: FULL SURFACE

SELECT MODELS	NGP	ROTON	PEMKO	STANLEY	ABH	PBB	IVES
SL21 HD300		780-210	FS				
SL21 HD600	HD2100	780-210HD	FSHD	665HD	A210HD	CG33C	210XY**
SL57 HD300		780-157	FSCP	664			
SL57 HD600	HD5700	780-157HD	FSCPHD	664HD	A570HD	CG33N	157XY**

* Not equivalent hinge but possible SELECT hinge substitution depending on application.

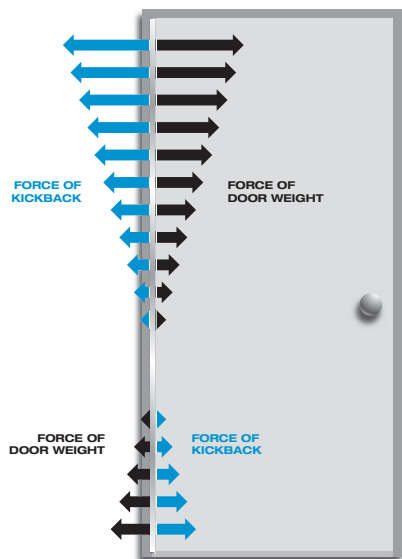
** Compatible with inset & profile.

No equivalent hinge available from this manufacturer.

HINGE STRESS COMPARISON

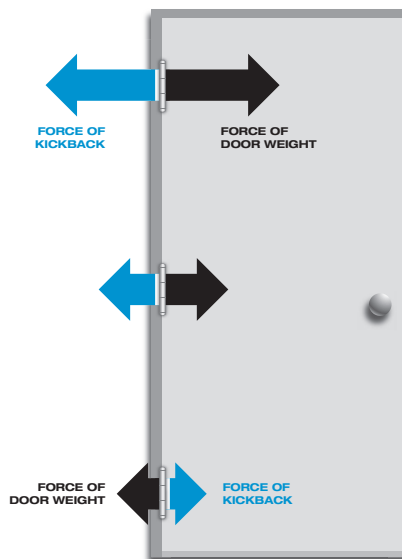
CONTINUOUS HINGES

SELECT continuous hinges unite the door and frame into an integrated, sag-free unit. "Kickback" energy dissipates along the entire length of the door and frame and prevents hinge failure.



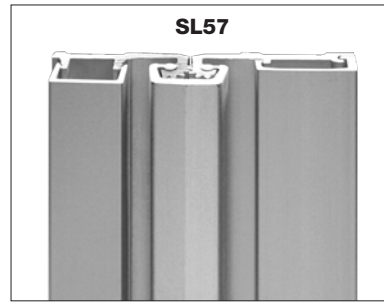
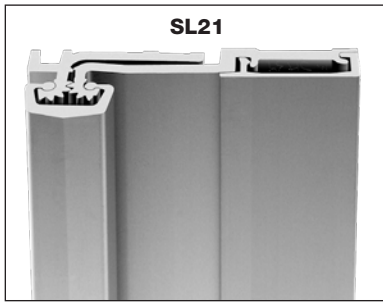
CONVENTIONAL BUTT HINGES

On conventional hinges, opening and "kickback" energy from closers and automatic operators concentrates on the top butt hinge. This force works against the top hinge, eventually forcing it apart or pulling it from the frame/door.



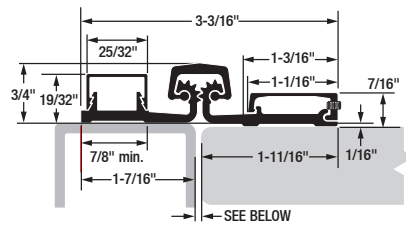
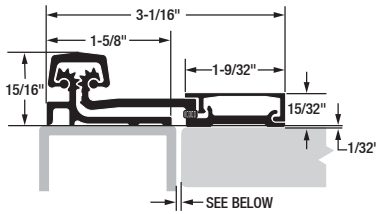
FULL SURFACE

Full Surface Geared Continuous Hinges



Model SL21 requires repositioning of existing overhead closer(s) to match the swing clear pivot point of the hinge. Failure to do so will prevent the door from opening more than 70 degrees. Attach hinge leaf cover before reinstalling closer(s).

Model SL57 requires a minimum 7/8" frame face width for mounting. On wider frames, mark a line at 1" to 1-5/16" from center of clearance between frame and closed door. Align the edge of hinge frame leaf with mark.



Door Clearances

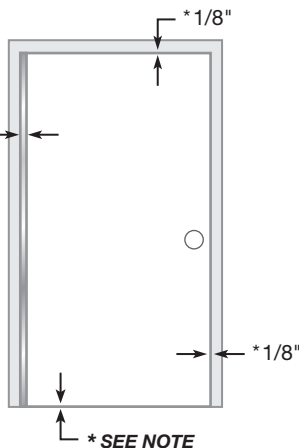
For Square and Beveled-Edge Doors

IMPORTANT: All uncut SL21 and SL57 hinges are non-handed and templated. They become handed after cutting. If door inset is required, install a continuous piece of shim under the door leaf.

* **NOTE:** Refer to NFPA 80 manual for clearance requirements on fire-rated entrances.

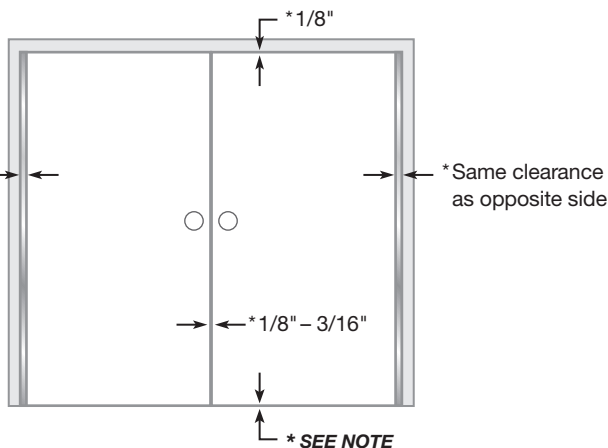
Single Door Hinge side clearance

*1/16" – 1/8" min.



Double Doors (Pair) Hinge side clearance

*1/16" – 1/8" min.



Important Warranty Information:

The following actions will void any warranty, expressed or implied:

- Failure to install the hinge according to manufacturer's specifications and requirements. (For more information, visit selecthingerequirements.com.)
- Use of fasteners other than those supplied with the hinge.
- Unauthorized field modifications, including alteration or removal of the factory-applied lubricant, altering the original finish or painting the hinge.

Reinforcing & Rivnuts®

No hinge reinforcement is necessary except on extremely high-frequency, extremely tall, extremely heavy or extra-wide doors. Rivnuts are recommended for use in the frame when the door exceeds 450 lbs.

NOTE: Only SELECT steel Rivnuts® are to be used with fire-rated SELECT hinges.

Grouted/Slushed-in Frames

For ease of installation, it is recommended some sort of mudguard be installed behind the frame. Do not use self-drilling, thread-forming (SDTF) screws to drill into grouted frames. If mudguards have not been used, carefully drill pilot holes through frame and remove grout for screw clearance. Do not oversize holes in frame.

Fire-Rated Hinges

All full surface SELECT hinges are 90-minute UL-rated, without fire pins or studs. Please contact SELECT for complete information about its fire-rated hinges.



Tools Needed

- Metal-cutting saw
- Tape measure
- #13 or 3/16" drill bit & 3/8" drill bit
- 5/32" drill bit (wood frames only)
- #3 Phillips drive
- 5/64" Allen wrench
- Hammer
- Shims

Parts Supplied

- #12-24 self-drilling, thread-forming (SDTF) 410 SS Phillips undercut flathead screws
- #12-24 self-drilling, thread-forming (SDTF) 410 SS Phillips undercut panhead screws
- 1/4-20 barrel nuts (sexnuts)
- 1/4-20 shoulder screws
- 7/32" center punch
- 3/8" center punch
- Set screws

Optional Parts

- #12 410 SS Phillips undercut flathead wood screws
- #12-24 thread-forming (TF) 410 SS Phillips undercut flathead screws
- Long barrel nuts for 2" to 2-1/4" thick doors
- Protective gloves are recommended

How to Cut the Hinge to Fit

- A. Keep hinge in "door closed" position (Fig. 1).
- B. Using a metal-cutting saw, begin the cut through the gear cap first.

NOTE: DO NOT cut through a set screw bearing.

- C. Loosen set screw (if necessary) from side of door leaf cover with 5/64" Allen wrench (Fig. 1).
- D. Remove door leaf cover by sliding it off uncut end of hinge.
- E. Reinstall any set screw bearing that may have been cut off.

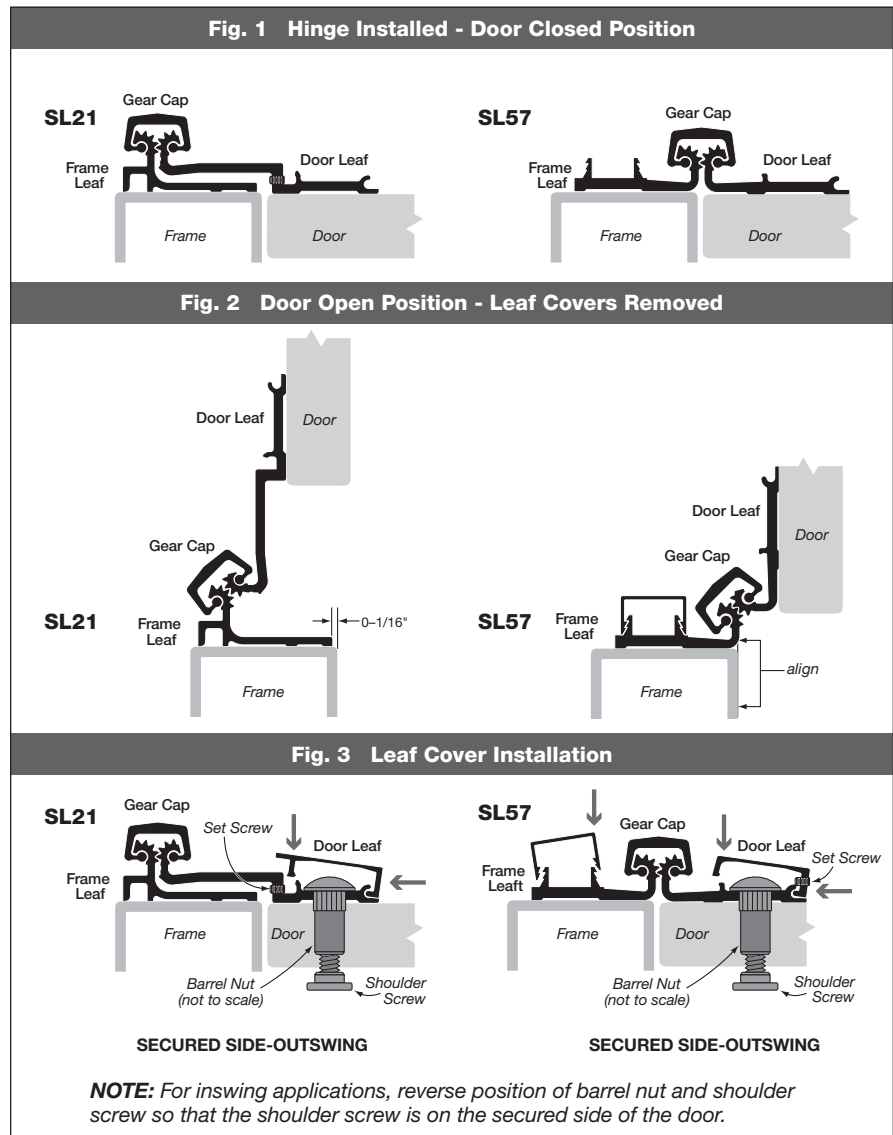
A. Attach Hinge to Frame

NOTE: Remove leaf cover(s) if not already removed. See step C above for door cover.

1. Shim hinge to 1/8" below the header to allow for door clearance.
2. Hold hinge in "door open" position (Fig. 2) and align frame leaf with inner edge of door frame or your alignment mark.
3. Mark (or centerpunch) two holes at top and two holes at bottom of frame leaf.

NOTE: TF screws and wood screws require pilot holes at marked locations. SDTF screws do not require pilot holes.

4. If using SDTF screws, go to Step 5. If using TF or wood screws, drill holes at marked locations.
 - Metal frame: Use #13 (.185") bit or 3/16" (.188") bit
 - Wood frame: Use 5/32" (.156") bit
5. Fasten frame leaf to door frame using two screws at the top and two screws at the bottom.



- Metal frame: Use #12-24 TF flathead screws provided, or use #12-24 SDTF flathead screws (provided on request)
- Wood frame: Use #12 flathead wood screws (provided on request)

B. Prepare Door

6. Shim door into opening to provide required hinge clearances.

IMPORTANT: Top end of the hinge must be flush with the top of the door.
7. Mark locations for the four SDTF panhead screws on the door using 7/32" center punch.
8. With #3 Phillips drive, temporarily attach door leaf to door through the four locator holes with SDTF panhead screws provided.
9. Remove shims and check door clearances, alignment and operation.

NOTE: Door may sag slightly when shims are removed. Note the amount of adjustment needed to bring door back into alignment. **DO NOT PROCEED UNTIL DOOR OPERATES PROPERLY.**
10. Mark locations for barrel nuts on the door using 3/8" center punch.

11. Remove door and lay it flat. Use 3/8" drill bit to drill holes at marked locations.

NOTE: Be sure to drill squarely through door.

C. Attach Door to Hinge

12. Fasten door to door leaf with the barrel nuts and 1/4-20 shoulder screws.

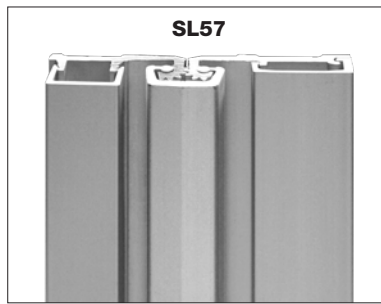
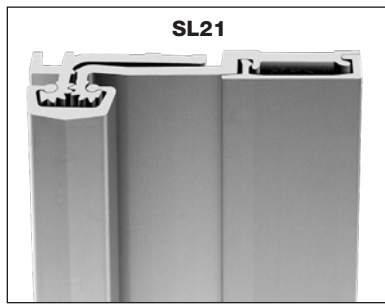
NOTE: Always install shoulder screws on the secured side of the door (Fig. 3).
13. Mark (or centerpunch) remaining frame leaf hole locations. Drill holes in frame through the frame leaf and secure with flathead screws.
14. Secure door to door leaf with barrel nuts and 1/4-20 shoulder screws.

NOTE: Always install shoulder screws on the secured side of the door (Fig. 3).

D. Install Leaf Covers

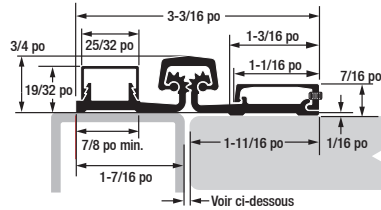
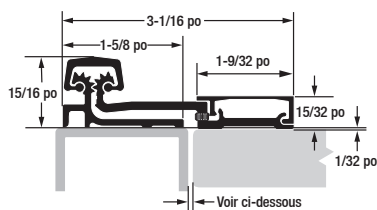
15. Align leaf cover with top edge of hinge.
16. Starting from the top and working downward, apply pressure to leaf cover to snap it into place (Fig. 3).

NOTE: If you use a hammer to tap cover into place, be sure to protect the surface of the cover from damage.
17. Tighten set screws with 5/64" Allen wrench.



Le modèle SL21 nécessite de repositionner le(s) dispositif(s) de fermeture à crémaillère elliptique existant(s) pour qu'ils correspondent au point de pivotement libre de la charnière. Si vous ne le faites pas, la porte ne pourra pas s'ouvrir à plus de 70 degrés. Fixez le cache du vantail à charnière avant de réinstaller le(s) dispositif(s) de fermeture.

Le modèle SL57 nécessite une largeur minimale de 7/8 po de la face du cadre pour le montage. Sur les cadres plus larges, marquez une ligne à 1 po - 1 5/16 po du centre du dégagement entre le cadre et la porte fermée. Alignez le bord du vantail à cadre de charnière avec la marque.



Dégagement des portes

Pour les portes à bord carré et à bord biseauté

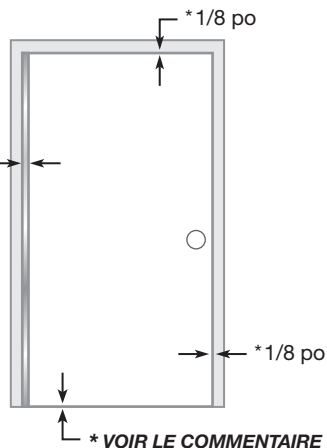
IMPORTANT : Toutes les charnières SL21 et SL57 non coupées sont réversibles et gabariées. Elles adoptent une direction d'ouverture après la coupe. Si un encastrement de la porte est nécessaire, installez une pièce de cale continue sous le vantail de la porte.

* **REMARQUE :** Se référer au manuel NFPA 80 pour les exigences en matière de dégagement sur les entrées avec portes coupe-feu.

Porte unique

Dégagement latéral des charnières

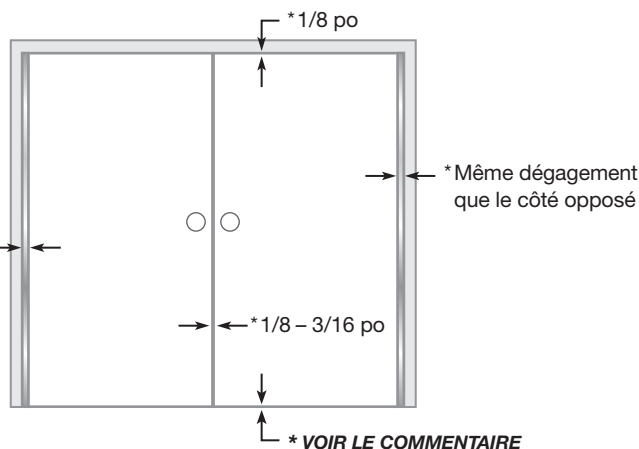
* 1/16 po - 1/8 po min.



Porte à deux battants (paire)

Dégagement latéral des charnières

* 1/16 po - 1/8 po min.



Informations importantes concernant la garantie :

Les actions suivantes annuleront toute garantie, explicite ou implicite :

- Le fait de ne pas installer la charnière conformément aux spécifications et aux exigences du fabricant. (Pour plus d'information, visitez le site Webselecthingerequirements.com).
- Utilisation de fixations autres que celles fournies avec la charnière.
- Modifications non autorisées sur le terrain, y compris l'altération ou le retrait du lubrifiant appliqué en usine, l'altération de la finition originale ou la peinture de la charnière.

Renforts et rivets Rivnuts®

Aucun renforcement des charnières n'est nécessaire, sauf pour les portes à très haute fréquence, extrêmement hautes, extrêmement lourdes ou très larges. L'utilisation d'écrous à rivet est recommandée dans le cadre lorsque la porte dépasse 450 lb.

REMARQUE : Seuls les écrous Rivnuts® en acier SELECT doivent être utilisés avec les charnières SELECT coupe-feu.

Cadres jointoyés/enrobés

Pour faciliter l'installation, il est recommandé d'installer une sorte de garde-boue derrière le cadre. N'utilisez pas de vis auto-foreuses et autotaraudeuses pour percer les cadres scellés.

Si aucun garde-boue n'a été utilisé, percez soigneusement des avant-trous dans le cadre et retirez le coulis pour dégager les vis. Ne pas surdimensionner les trous dans le cadre.

Charnières coupe-feu



Toutes les charnières SELECT en stock sont classées UL pendant 90 minutes, sans gond. Veuillez contacter SELECT pour obtenir des informations complètes sur ses charnières coupe-feu.

Outillage nécessaire

- Scie à métaux
- Mètre ruban
- Foret #13 ou de 3/16 po & foret de 3/8 po
- Foret de 5/32 po (seulement pour cadre de porte en bois)
- Tournevis Phillips #3
- Clé Allen 5/64 po
- Marteau
- Cales

Pièces fournies

- Vis Phillips perçantes/taraudantes (SDTF) à tête fraisée plate, #12-24, acier inox. 410
- Vis Phillips perçantes/taraudantes (SDTF) #12-24, acier inox. 410, à tête fraisée bombée
- Écrous cylindriques 1/4-20 (sexnuts)
- Vis à collet 1/4-20
- Pointeau 7/32 po; Pointeau 3/8 po
- Vis de calage

Pièces facultatives

- Vis à bois Phillips, à tête fraisée plate, #12, acier inox. 410
- Vis Phillips taraudantes (TF) #12-24, acier inox. 410, à tête fraisée plate
- Écrous cylindriques longs pour porte d'épaisseur 2 po à 2-1/4 po
- L'utilisation de gants de protection est recommandée

Découpage et ajustement de la charnière

- A. Maintenir la charnière à la position correspondant à la porte fermée (Fig. 1).
- B. Utiliser une scie à métaux – commencer la coupe à travers le couvre-charnière.

NOTE: NE PAS couper au niveau de l'appui d'une vis de calage.

- C. Desserrer la vis de calage (si nécessaire) sur le côté du profilé de garniture de l'élément ouvrant – utiliser une clé Allen de 5/64 po (Fig. 1).
- D. Ôter le profilé de garniture de l'élément ouvrant – faire glisser le profilé vers l'extrémité non coupée de la charnière.
- E. Réinstaller tout appui de vis de calage qui pourrait avoir été coupé.

A. Fixation de la charnière sur le cadre de porte

NOTE : Ôter le(s) profilé(s) de garniture si cela n'a pas déjà été fait; voir l'étape C ci-dessus pour le profilé de garniture de l'élément ouvrant.

1. Placer une cale pour positionner la charnière à 1/8 po au-dessous de la traverse du cadre de porte, pour établir l'espace libre de séparation au sommet de la porte.
2. Maintenir la charnière à la position correspondant à la porte ouverte (Fig. 2) et aligner l'élément dormant de la charnière avec la rive interne du cadre de porte ou avec la ligne de repérage tracée précédemment.
3. Marquer (crayon ou pointeau) la position de deux trous au sommet et de deux trous en bas de l'élément dormant de la charnière.

NOTE : Si on doit utiliser des vis à bois ou des vis taraudantes, il faudra percer des avant-trous aux emplacements marqués; aucun avant-trou n'est nécessaire pour les vis perçantes/taraudantes (SDTF).

4. Si on doit utiliser des vis perçantes/taraudantes (SDTF), passer à l'étape 5. Si on doit utiliser des vis à bois ou des vis taraudantes, percer les avant-trous aux emplacements marqués.

■ Cadre métallique : Utiliser un foret #13 (0,185 po) ou de 3/16 po (0,188 po)

■ Cadre en bois : Utiliser un foret de 5/32 po (0,156 po)

5. Fixer l'élément dormant de la charnière sur le cadre de porte – placer deux vis au sommet et deux vis en bas.

Fig. 1 Charnière installée - Porte à la position de fermeture

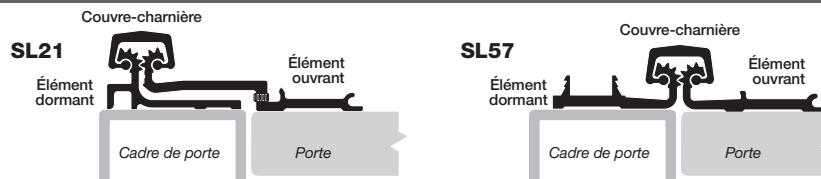


Fig. 2 Porte à la position d'ouverture - Profilés de garniture déposés

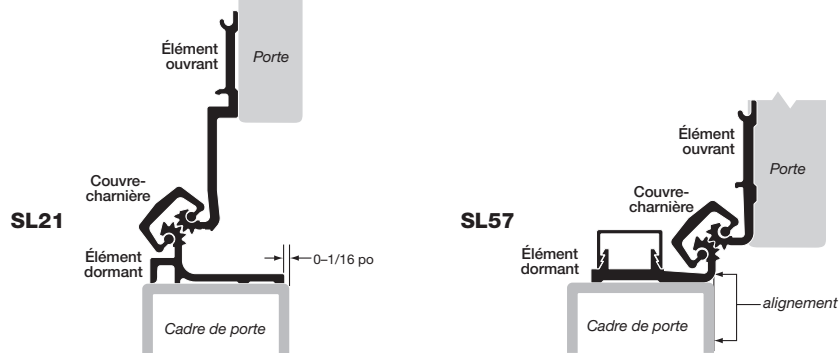
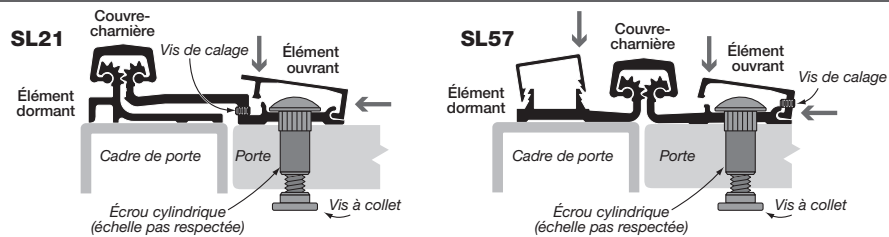


Fig. 3 Installation des profilés de garniture



PIVOTEMENT D'OUVERTURE VERS L'EXTÉRIEUR

PIVOTEMENT D'OUVERTURE VERS L'EXTÉRIEUR

NOTE : Lorsque le pivotement d'ouverture est effectué vers l'intérieur du local sécurisé, inverser la position des écrous cylindriques et des vis à collet – la tête des vis à collet doit toujours être placée sur la face de la porte accessible dans le local sécurisé.

- Cadre métallique : Utiliser les vis taraudantes fournies #12-24 (TF; tête plate), ou des vis perçantes/taraudantes (SDTF; tête plate) #12-24 (fourniture sur demande)
- Cadre en bois : Utiliser des vis à bois #12 à tête plate (fourniture sur demande)

B. Préparation de la porte

6. Utiliser des cales pour positionner la porte dans l'embrasure, pour établir les espaces libres de séparation nécessaires pour la charnière.

IMPORTANT : L'extrémité supérieure de la charnière doit être en affleurement avec le sommet de la porte.

7. Marquer sur la porte la position des quatre vis perçantes/taraudantes (SDTF) à tête fraisée bombée – utiliser un pointeau de 7/32 po.
8. Utiliser un tournevis Phillips #3 – fixer temporairement l'élément ouvrant sur la porte (placer dans les avant-trous quatre vis perçantes/taraudantes (SDTF) à tête bombée (fournies)).
9. Ôter les cales de positionnement et vérifier que les espaces de séparation établis sont adéquats; vérifier également le bon alignement et le pivotement correct de la porte.

NOTE : La porte peut s'affaisser légèrement lors du retrait des cales; noter l'amplitude de l'ajustement qu'il faudra effectuer pour rétablir l'alignement correct de la porte. **NE PAS POURSUIVRE AVANT D'AVOIR ÉTABLI LE PIVOTEMENT SATISFAISANT DE LA PORTE.**

10. Marquer sur la porte la position des écrous cylindriques – utiliser un pointeau de 3/8 po.
11. Déposer la porte; placer la porte à plat; utiliser un foret de 3/8 po pour percer les trous aux emplacements marqués.

NOTE : Veiller à percer les trous parfaitement perpendiculairement à la surface de la porte.

C. Fixation de la porte sur la charnière

12. Fixer la porte sur l'élément ouvrant de la charnière – utiliser les ensembles écrou cylindrique/vis à collet (1/4-20).

NOTE : Placer toujours la tête des vis à collet sur la face de la porte accessible dans le local sécurisé (Fig. 3).

13. Marquer (crayon ou pointeau) la position des trous restants sur l'élément dormant de la charnière. Percer les trous dans le cadre de porte à travers l'élément dormant de la charnière, et placer des vis à tête plate.

14. Fixer la porte sur l'élément ouvrant de la charnière – utiliser les ensembles écrou cylindrique/vis à collet (1/4-20).

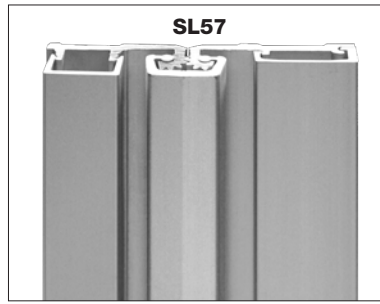
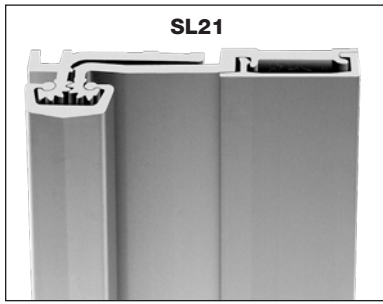
NOTE : Placer toujours la tête des vis à collet sur la face de la porte accessible dans le local sécurisé (Fig. 3).

D. Installation des profilés de garniture

15. Aligner le profilé de garniture avec la rive supérieure de la charnière.
16. Commencer au sommet et progresser vers le bas – appliquer une pression sur le profilé de garniture pour provoquer l'emboîtement en place (Fig. 3).

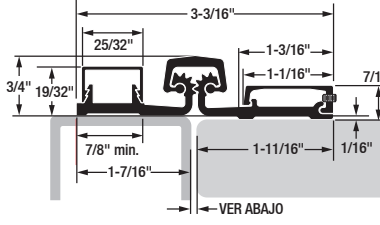
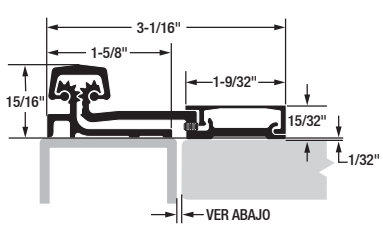
NOTE : Si on utilise un marteau pour provoquer l'emboîtement du profilé de garniture, veiller à protéger la surface du profilé de garniture pour ne pas l'endommager.

17. Serrer les vis de calage – utiliser une clé Allen de 5/64 po.



El modelo SL21 requiere que el reposicionamiento del (de los) cierrapuertas superior(es) coincida con el centro giratorio de giro total de la bisagra. De lo contrario, la puerta no podrá abrir más de 70 grados. Fije la cubierta de hoja de la bisagra antes de instalar el (los) cierrapuertas.

El modelo SL57 requiere un ancho mínimo de 7/8" en la cara del marco para el montaje. En los marcos más anchos, marque una línea de 1" a 1 - 5/16" desde el centro del espacio libre entre el marco y la puerta cerrada. Alinee el borde de la hoja de la bisagra con la marca.



Información importante sobre la garantía:

Las acciones siguientes invalidarán cualquier garantía, ya sea explícita o implícita:

- No instalar la bisagra siguiendo las especificaciones y requisitos del fabricante. (Visite selecthingerequirements.com para obtener más información)
- Usar sujetadores que no sean los que se suministran con la bisagra.
- Modificaciones de terreno no autorizadas, como alterar o retirar el lubricante aplicado en la fábrica, alterar el acabado original o pintar la bisagra.

Espacios libres de puerta

Para puertas de borde cuadrado y de borde biselado

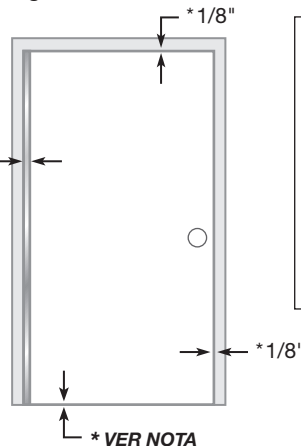
IMPORTANTE: Todas las bisagras SL21 y SL57 sin cortar son reversibles y tienen plantilla. Se vuelven específicas para una orientación (izquierda o derecha) después de ser cortadas. Si se requiere que la puerta tenga holgura, coloque un trozo de cuña continuo debajo de la hoja de la puerta.

* **NOTA:** Consulte el manual NFPA 80 para ver los requisitos de espacio libre en las entradas con clasificación ignífuga.

Puerta simple

Espacio libre en lado de bisagra

*1/16" - 1/8" min.



Refuerzo y Rivnuts®

No es necesario reforzar la bisagra excepto en puertas de uso extremadamente frecuente, extremadamente altas, extremadamente pesadas o extra anchas. Se recomienda el uso de Rivnuts en el marco cuando la puerta exceda las 450lb.

NOTA: Con las bisagras SELECT de clasificación ignífuga solo se deben usar Rivnuts® de acero SELECT.

Marcos enlechados / Rellenos con mortero

Para facilitar la instalación, se recomienda instalar algún tipo de guardalodos detrás del marco. No use tornillos autoperforantes, autorroscantes (SDTF) para perforar los marcos enlechados.

Si no se utilizaron guardalodos, barre el marco con cuidado para crear orificios piloto y retire la lechada para asegurar la holgura del tornillo. Asegúrese de que los orificios del marco no sean demasiado grandes.

Bisagras de clasificación ignífuga

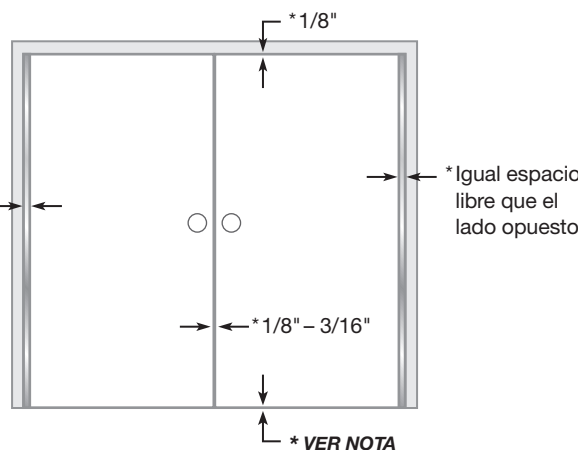
Todas las bisagras SELECT en inventario están homologadas por UL para 90 minutos, sin pasadores. Contacte a SELECT para obtener toda la información sobre estas bisagras de clasificación ignífuga.



Puertas dobles (par)

Espacio libre en lado de bisagra

*1/16" - 1/8" min.



Herramientas necesarias

- Sierra para cortar metal
- Cinta para medir
- Broca N° 13 o de 3/16" y broca de 3/8"
- Broca de 5/32" (solamente para marcos de madera)
- Destornillador Phillips N° 3
- Llave Allen de 5/64"
- Martillo
- Cuñas

Piezas suministradas

- Tornillos Phillips roscadores autorroscantes (SDTF) N° 12-24 de cabeza plana sesgada
- Tornillos Phillips de acero inoxidable 410 roscadores autorroscantes (SDTF) N° 12-24 de cabeza troncocónica sesgada
- Tuercas cilíndricas de 1/4-20
- Tornillos de tope de 1/4-20
- Punzón de 7/32" y punzón de 3/8"
- Tornillos de ajuste

Piezas opcionales

- Tornillos Phillips de acero inoxidable 410 N° 12 de cabeza plana sesgada, para madera
- Tornillos Phillips de acero inoxidable 410 roscadores (TF) N° 12-24 de cabeza plana sesgada
- Tuercas cilíndricas largas para puertas con un espesor de 2" a 2 1/4"
- Se recomienda el uso de guantes protectores

Cómo cortar la charnela al tamaño

- Mantenga la charnela en la posición de "puerta cerrada" (Fig.1).
- Usando una sierra para cortar metal, comience a cortar primero a través de la tapa del engranaje.

NOTA: NO corte por el rodamiento del tornillo de ajuste.

- Afije el tornillo de ajuste (si es necesario) del lado de la cubierta de la hoja de la puerta con una llave Allen de 5/64" (Fig. 1).
- Quite la cubierta de la hoja de la puerta deslizando la por el extremo sin cortar de la charnela.
- Vuelva a instalar cualquier rodamiento de los tornillos de ajuste que pudiera haberse cortado.

A. Fije la charnela al marco

NOTA: Retire la(s) cubierta(s) de la hoja si no lo ha hecho todavía. Vea el paso C anterior sobre la cubierta de la puerta.

- Coloque cuñas en la charnela a 1/8" debajo del travesaño para dejar tolerancia para la puerta.
- Sostenga la charnela en la posición de "puerta abierta" (Fig. 2) y alinee la hoja del marco con el borde interior del marco de la puerta o la marca de alineación.

- Marque (o punce) dos orificios en la parte superior y dos orificios en la parte inferior de la hoja del marco.

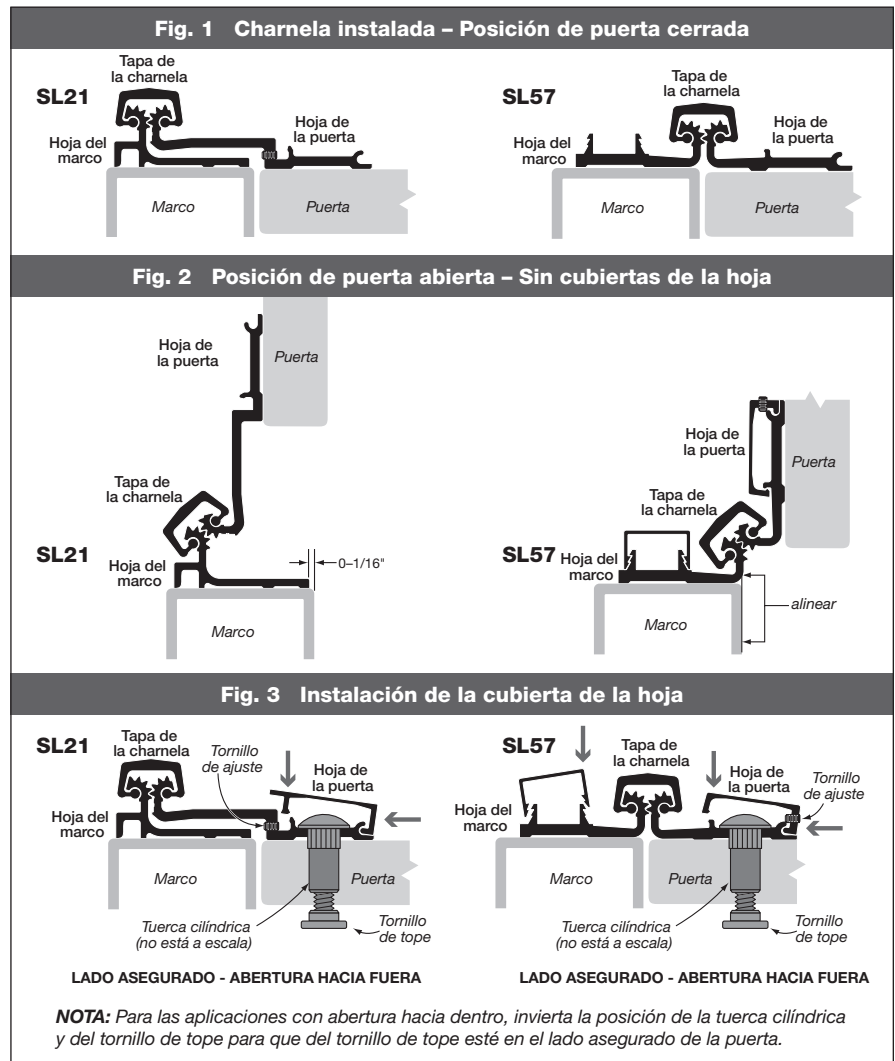
NOTA: Los tornillos roscadores (TF) y los de madera necesitan orificios piloto en las ubicaciones marcadas. Los tornillos roscadores autorroscantes (SDTF) no necesitan orificios piloto.

- Si va a usar tornillos roscadores autorroscantes (SDTF), vaya al paso 5. Si va a usar tornillos roscadores (TF) o para madera, taladre orificios en los lugares marcados.

■ Marco de metal: Use una broca N° 13 (0,185") o de 3/16" (0,188")

■ Marco de madera: Use una broca de 5/32" (0,156")

- Sujete la hoja del marco al marco de la puerta usando dos tornillos en la parte superior y dos tornillos en la parte inferior.



- Marco de metal: Use los tornillos de cabeza plana roscadores N° 12-24 TF provistos o use tornillos de cabeza plana roscadores autorroscantes N° 12-24 SDTF (provistos bajo pedido)
- Marco de madera: Use tornillos de cabeza plana para madera N° 12 (provistos bajo pedido)

B. Prepare la puerta

- Acuñe la puerta en la abertura para proporcionar las tolerancias requeridas para la charnela.

IMPORTANTE: El extremo superior de la charnela debe estar alineado con la parte superior de la puerta.

- Marque las ubicaciones para los cuatro tornillos roscadores autorroscantes (SDTF) de cabeza troncocónica en la puerta usando el punzón de 7/32".
- Con el destornillador Phillips N° 3, sujete provisoriamente la hoja de la puerta a la puerta a través de los cuatro orificios de ubicación con los tornillos roscadores autorroscantes (SDTF) de cabeza troncocónica provistos.
- Quite las cuñas y verifique las tolerancias, la alineación y el funcionamiento de la puerta.

NOTA: La puerta puede caerse ligeramente cuando se quitan las cuñas. Fíjese cuánto debe ajustar la puerta para alinearla. **NO CONTÍNE HASTA QUE LA PUERTA FUNCIONE COMO ES DEBIDO.**

- Marque las ubicaciones para las tuercas cilíndricas en la puerta usando el punzón de 3/8".

- Retire la puerta y colóquela en posición horizontal. Use una broca de 3/8" para taladrar los orificios en los lugares marcados.

NOTA: Cerciórese de taladrar la puerta en forma recta.

C. Fije la puerta a la charnela

- Asegure la puerta a la hoja de la puerta con las tuercas cilíndricas y los tornillos de tope de 1/4-20.

NOTA: Instale los tornillos de tope siempre en el lado asegurado de la puerta (Fig. 3).

- Marque (o punce) los lugares restantes de los orificios de la hoja del marco. Taladre los orificios en el marco a través de la hoja del marco y asegúrelos con los tornillos de cabeza plana.

- Asegure la puerta a la hoja de la puerta con las tuercas cilíndricas y los tornillos de tope de 1/4-20.

NOTA: Instale los tornillos de tope siempre en el lado asegurado de la puerta (Fig. 3).

D. Instale las cubiertas de la hoja

- Alinee la cubierta de la hoja con el extremo superior de la charnela.

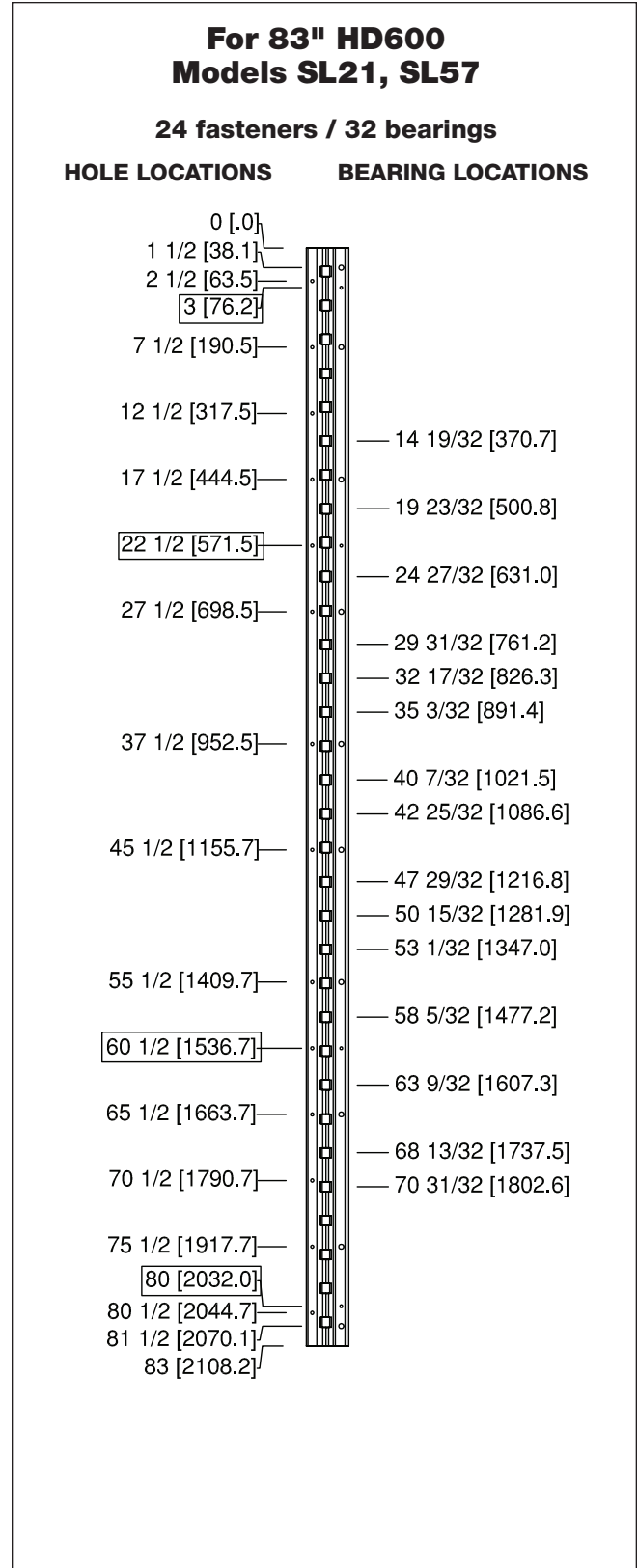
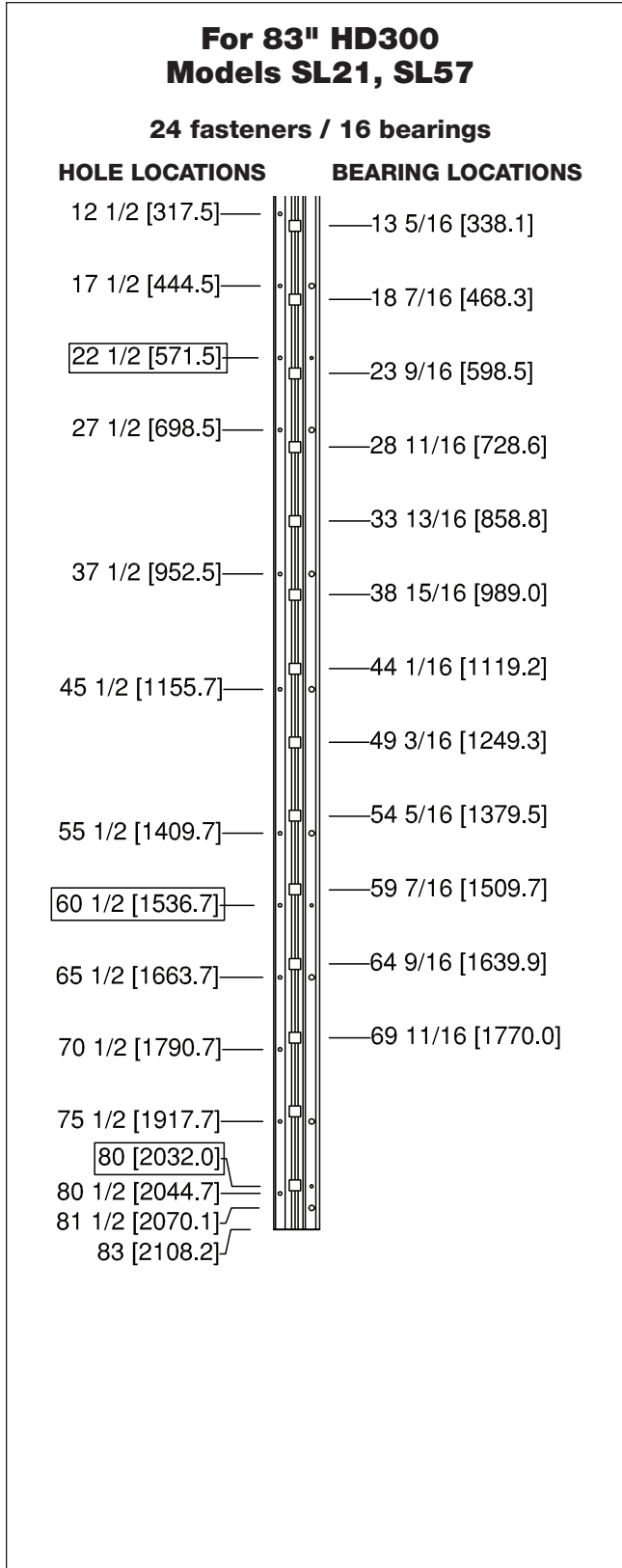
- Comenzando desde la parte superior y trabajando hacia abajo, aplique presión a la cubierta de la hoja para encajarla en su lugar (Fig. 3).

NOTA: Si usa un martillo para colocar la cubierta en su lugar, dé pequeños golpes asegurándose de proteger de daños a la superficie de la cubierta.

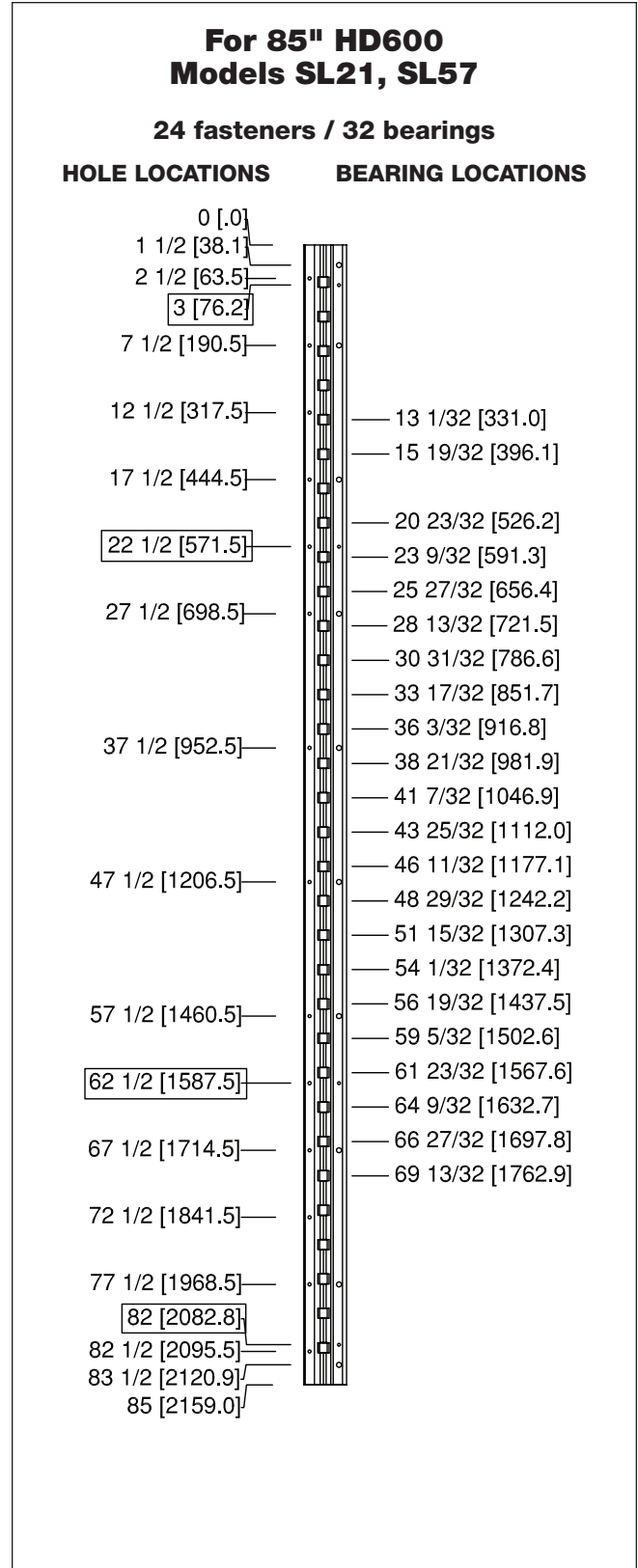
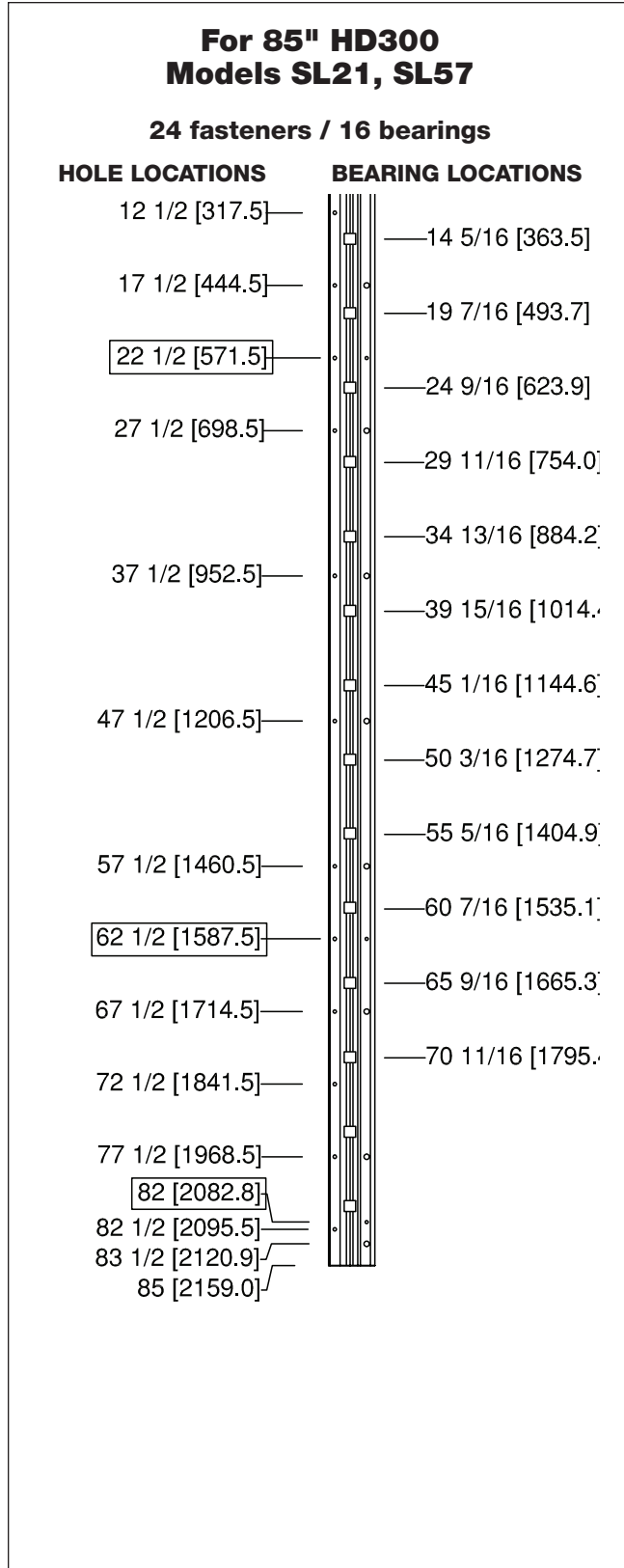
- Apriete los tornillos de ajuste con una llave Allen de 5/64".

Full Surface Geared Hinges

- All dimensions are measured in inches and [millimeters] from the top of the hinge to the centerline of the holes and bearings.
- Dimensions shown inside boxes are locator screw mounting holes.
- Choose location for CTW prep(s) from bearing slots dimensioned. CTW4/5 = 1 location; CTW8/10 = 2 locations; CTW12 = 3 locations.

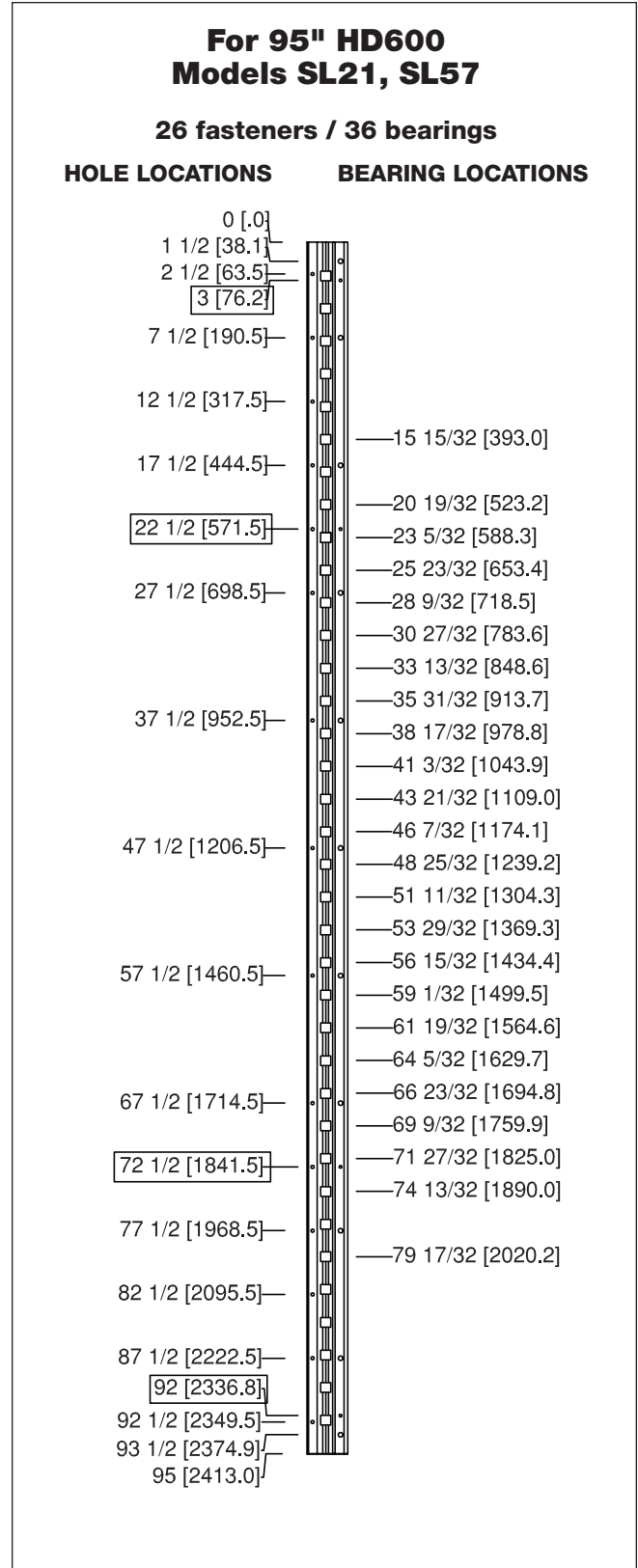
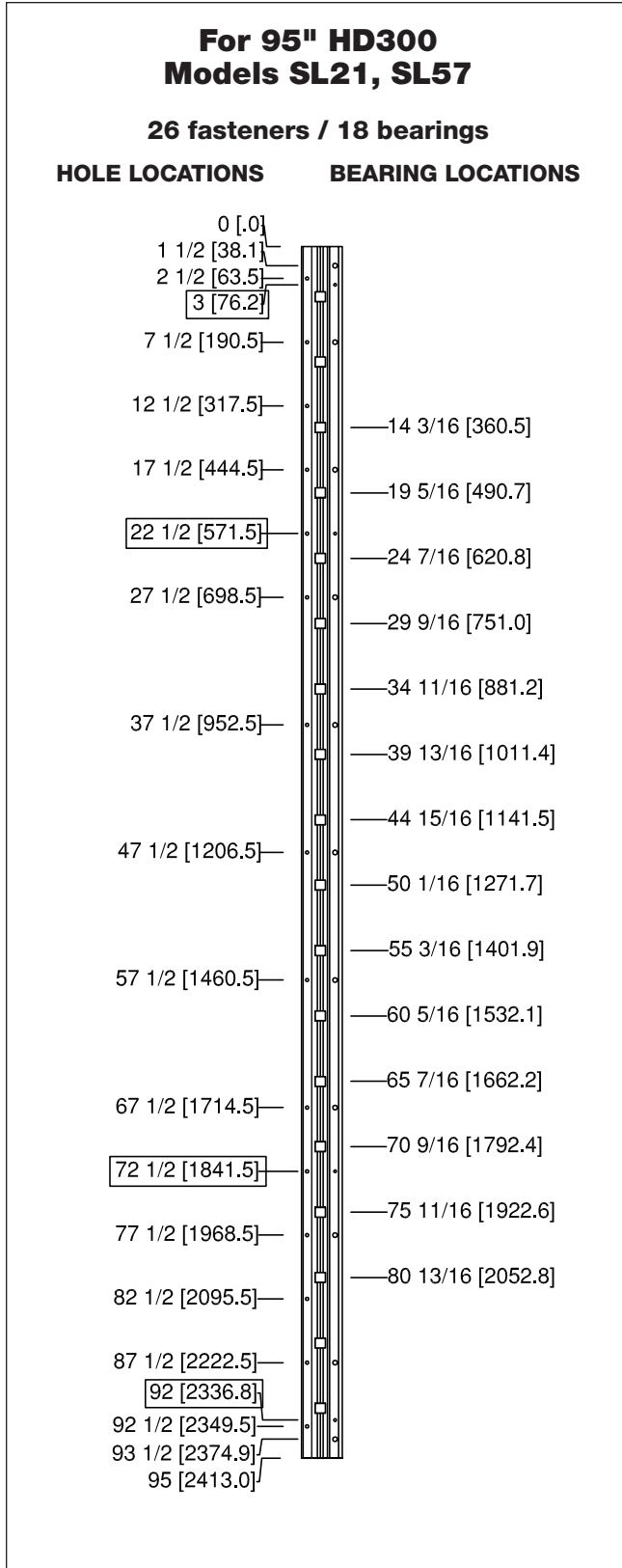


- All dimensions are measured in inches and [millimeters] from the top of the hinge to the centerline of the holes and bearings.
- Dimensions shown inside boxes are locator screw mounting holes.
- Choose location for CTW prep(s) from bearing slots dimensioned. CTW4/5 = 1 location; CTW8/10 = 2 locations; CTW12 = 3 locations.



Full Surface Geared Hinges

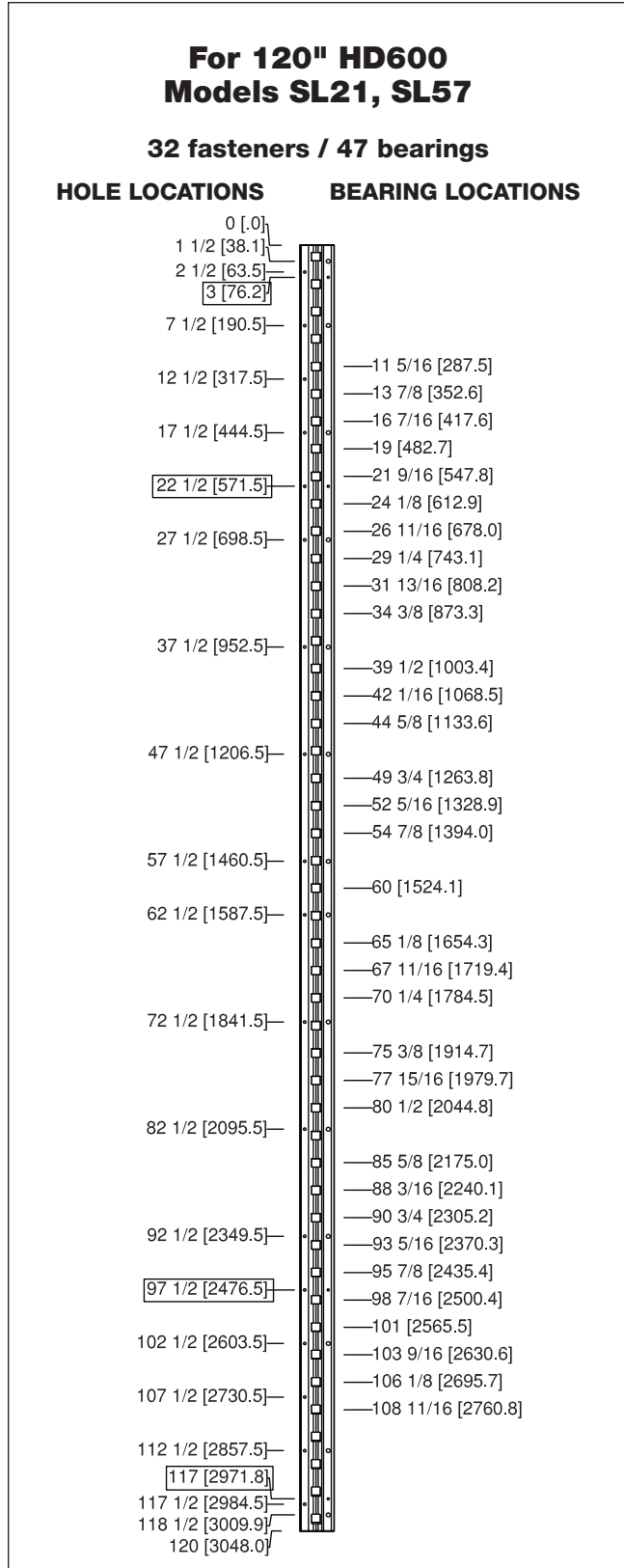
- All dimensions are measured in inches and [millimeters] from the top of the hinge to the centerline of the holes and bearings.
- Dimensions shown inside boxes are locator screw mounting holes.
- Choose location for CTW prep(s) from bearing slots dimensioned. CTW4/5 = 1 location; CTW8/10 = 2 locations; CTW12 = 3 locations.



Full Surface Geared Hinges

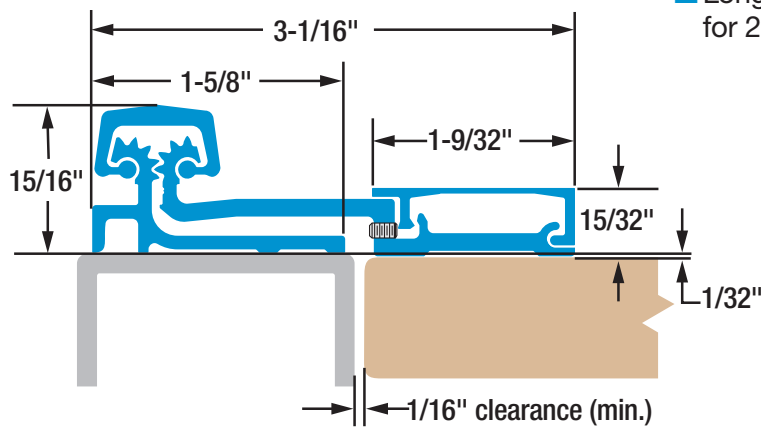


- All dimensions are measured in inches and [millimeters] from the top of the hinge to the centerline of the holes and bearings.
- Dimensions shown inside boxes are locator screw mounting holes.
- Choose location for CTW prep(s) from bearing slots dimensioned. CTW4/5 = 1 location; CTW8/10 = 2 locations; CTW12 = 3 locations.





- Swing-clear action
- Tamper-resistant, removable door leaf cover
- 1/32" door inset
- Standard barrel nuts accommodate 1-3/8" to 1-3/4" doors
- Long barrel nuts available for 2" to 2-1/4" doors



SL21

Full Surface Geared Continuous Hinge



Tested to last six decades



Reduce maintenance costs and hassles. Independent lab tests on an FRP door prove

SELECT hinges withstand 25 million cycles — more than 60 years of high-traffic use. Pair-Matched™ hinge leaves, lifetime lubrication and anodizing after machining deliver the longest life of any continuous hinge.

Covered by the only Continuous Warranty



Because SELECT geared continuous hinges have proven themselves in independent testing, we offer the industry's only Continuous Warranty. It

covers any failure of our aluminum geared continuous hinges — with no expiration date — as long as they are properly installed. Durability and worry-free performance ... guaranteed in writing. *The warranty that never ends for the hinge that never quits.SM*

Certified by U.S. Department of State



After brutal testing, the State Department granted a SELECT geared continuous hinge its 60-minute certification — the department's highest level. The hinge deflected bullets in the Ballistic Resistance Test and withstood sledgehammers,

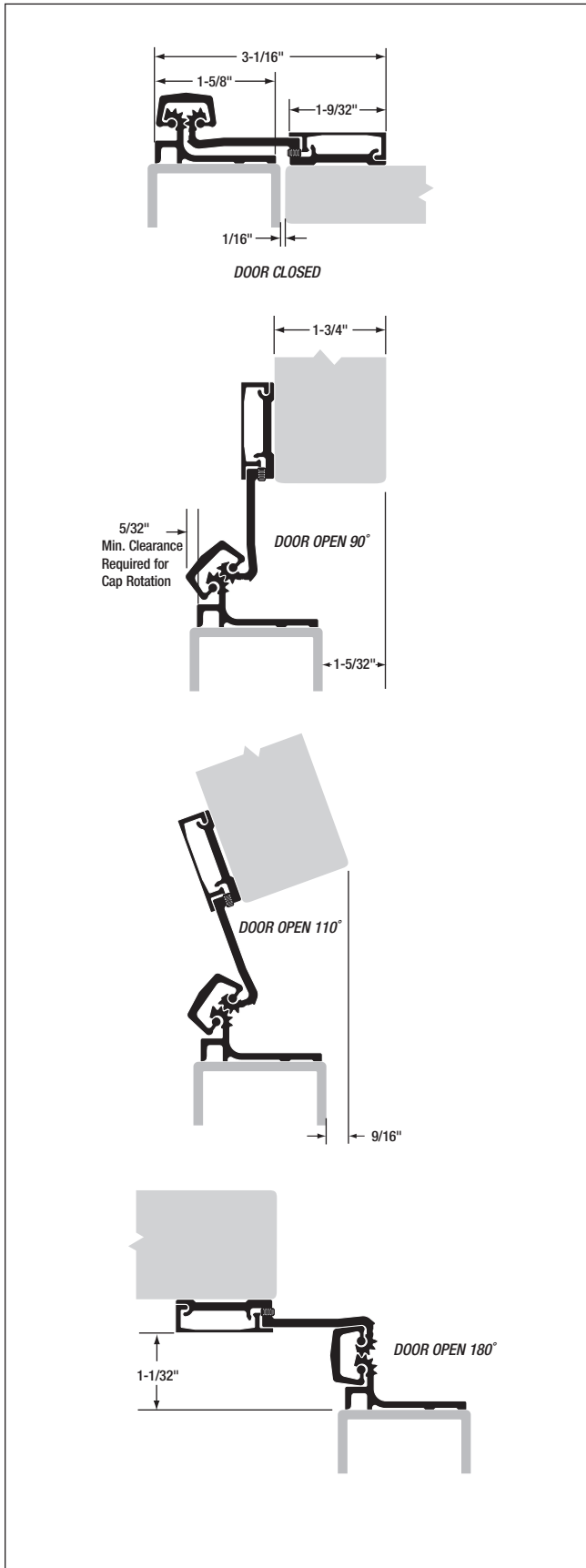
wedges and other tools in the Forced Entry Test. Approved for use in U.S. embassies overseas.

Geared to ship in 48 hours



SELECT ships hinges faster than anyone in the industry. 99.9% of our hinge orders ship in 48 hours; more than half are shipped in only 24 hours. Projects won't be delayed while waiting weeks for hinges.

NOTES:



MATERIAL: Extruded 6063 T6 aluminum alloy with self-lubricating polyester thrust bearings.

LENGTHS: 83", 85", 95" and 120" lengths standard for nominal door heights. Custom lengths are available.

LOAD/FREQUENCY RATINGS: For 1-3/8" – 1-3/4" doors standard; long barrel nuts available for 2" – 2-1/4" doors. 48" max. door width in 16 gauge hollow metal (min.) or 1/8" aluminum (min.).

Heavy Duty 300 – For high-frequency doors up to 300 lb. without frame or door reinforcement.

Heavy Duty 600 – For high-frequency doors up to 600 lb. Rivnuts are recommended in the frame when the door exceeds 450 lb.

FINISHES: All SL21 hinges are stocked in Clear and Dark Bronze anodized aluminum. Custom anodized or painted finishes are available. Product painted or anodized in the field voids the SELECT hinge warranty.

CLOSERS: Conventional overhead surface, concealed sliding arm overhead or floor closers may be used with SELECT hinges. Pivot-type floor closers (with a fixed, conflicting center pivot) must be replaced.

ORDER: Specify length, finish and heavy duty 300 (HD300) or heavy duty 600 (HD600). Also, specify door and frame screw applications. 12-24 x 3/4" self-drilling, thread-forming 410SS Phillips undercut flathead screws, 1/4-20 through-bolts and 1/4-20 shoulder screws (for doors up to 1-3/4" thick) are provided as a standard pack unless otherwise specified. Wood and thread-forming screws also available. Security screws optional at extra cost.



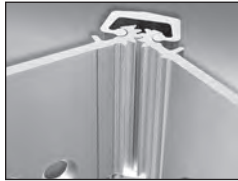
SL21 HINGE SCREW COUNT		
HINGE LENGTH & DUTY RATING	DOOR SCREWS	FRAME SCREWS
83" HD300/HD600	10	14
85" HD300/HD600	10	14
95" HD300/HD600	11	15
120" HD300/HD600	14	18

SELECT ADVANTAGES



PAIR-MATCHED™ HINGE LEAVES

Manufactured together, machined together and anodized together, making SELECT hinges fit your doors better and last longer. *An exclusive SELECT benefit.*



LIFETIME LUBRICATION

Eliminates the need for periodic maintenance. Quiet performance. Fights gear cap wear. *An exclusive SELECT benefit.*



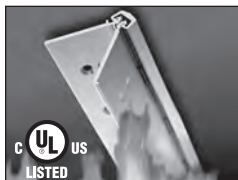
ANODIZED AFTER MACHINING

Delivers superior wear, durability and life. Inhibits corrosion. Few hinge makers follow SELECT's lead in using this superior manufacturing process.



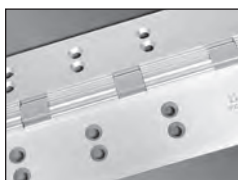
SUSTAINABLE

Made from up to 100% recycled aluminum. Reduces environmental impact and qualifies for LEED points. *An exclusive SELECT benefit.*



PATENTED 3-HR. FIRE RATING

Most SELECT hinges are fire rated for 90 minutes. 3-Hr. fire rating, optional at extra cost, approved for positive/negative pressure. No fire pins or studs required. Patented design innovation. *An exclusive SELECT benefit.*



CONSISTENT TEMPLATING

Hole pattern is identical on both Heavy Duty 300 and Heavy Duty 600 models, so SELECT hinges line up precisely for easier and faster installation. *An exclusive SELECT benefit.*



COATED FASTENERS

Provide additional corrosion protection with either self-drilling, thread-forming (SDTF) or thread-forming (TF) screws. *An exclusive SELECT benefit.*



CUSTOM COLORS

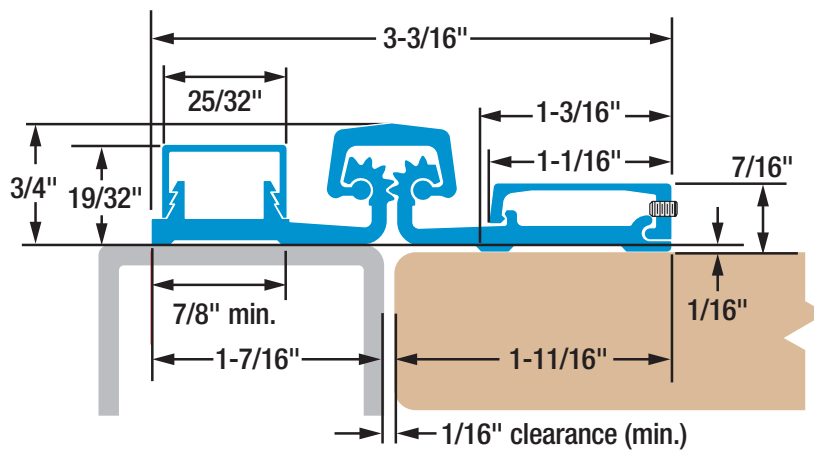
Match any paint color on the gear cap or the entire hinge and fasteners, including our always-in-stock Bone White gear caps. Anodized colors also available.

SELECT HINGE PERFORMANCE

- A SELECT geared continuous hinge has been tested in accordance with ANSI 250.4-1994 test procedure and acceptance criteria for physical endurance for steel doors and hardware and has surpassed 25,000,000 cycles during testing by an independent laboratory. On a door cycling 400,000 times per year, a SELECT hinge will be performing for over 62 years.
- SELECT geared continuous hinges are built to handle abuse from high-traffic applications. They are applied to the surface on the edge of the frame and door. No machining or reinforcement is required.
- The revolutionary SELECT geared continuous hinge puts an end to costly and irritating hinge failure problems, the most common cause of entrance failure.
- On conventional hinges, opening and “kick-back” energy concentrate on a few inches of fastened reinforcing plate — with the top hinge handling 100% of the force. Pinless SELECT hinges bond the door and frame into an integrated, sag-free unit. “Kick-back” energy dissipates along the entire length of the door and frame. (Compare this to a conventional hinge’s 4-1/2" to 5" at the top of the door and frame).
- SELECT geared continuous hinges eliminate the gap between the door and frame, providing a weatherproof, rust-proof, tamper-proof barrier. When the door is closed, there are no accessible screws, bolts or pins.
- SELECT SL21 geared continuous hinges are listed and tested by Underwriters Laboratories to meet the Positive and Negative pressure requirements of UL10B and UL10C, and are in accordance with UBC 7.2 (1997). SELECT SL21 geared continuous hinges are for use on swinging single fire doors (max. door opening of 4'x10') or pairs of fire doors (max. door opening of 8'x10'), including double egress, installed in masonry or drywall. SELECT SL21 geared continuous hinges are rated for up to 1-1/2 hours for wood composite and wood core type fire doors. A special patented process can be added to increase the fire rating to 3 hours (NO FIRE PINS OR STUDS REQUIRED) for hollow metal or steel covered composite type doors.



- Center pivot
- Frame leaf fits narrow (7/8") frame face
- Tamper-resistant, removable door leaf cover
- 1/16" door inset
- Standard barrel nuts accommodate 1-3/8" to 1-3/4" doors
- Long barrel nuts available for 2" to 2-1/4" doors



SL57

Full Surface Geared Continuous Hinge



Tested to last six decades



Reduce maintenance costs and hassles. Independent lab tests on an FRP door prove

SELECT hinges withstand 25 million cycles — more than 60 years of high-traffic use. Pair-Matched™ hinge leaves, lifetime lubrication and anodizing after machining deliver the longest life of any continuous hinge.

Covered by the only Continuous Warranty



Because SELECT geared continuous hinges have proven themselves in independent testing, we offer the industry's only Continuous Warranty. It

covers any failure of our aluminum geared continuous hinges — with no expiration date — as long as they are properly installed. Durability and worry-free performance ... guaranteed in writing. *The warranty that never ends for the hinge that never quits.™*

Certified by U.S. Department of State



After brutal testing, the State Department granted a SELECT geared continuous hinge its 60-minute certification — the department's highest level. The hinge deflected bullets in the Ballistic Resistance Test and withstood sledgehammers,

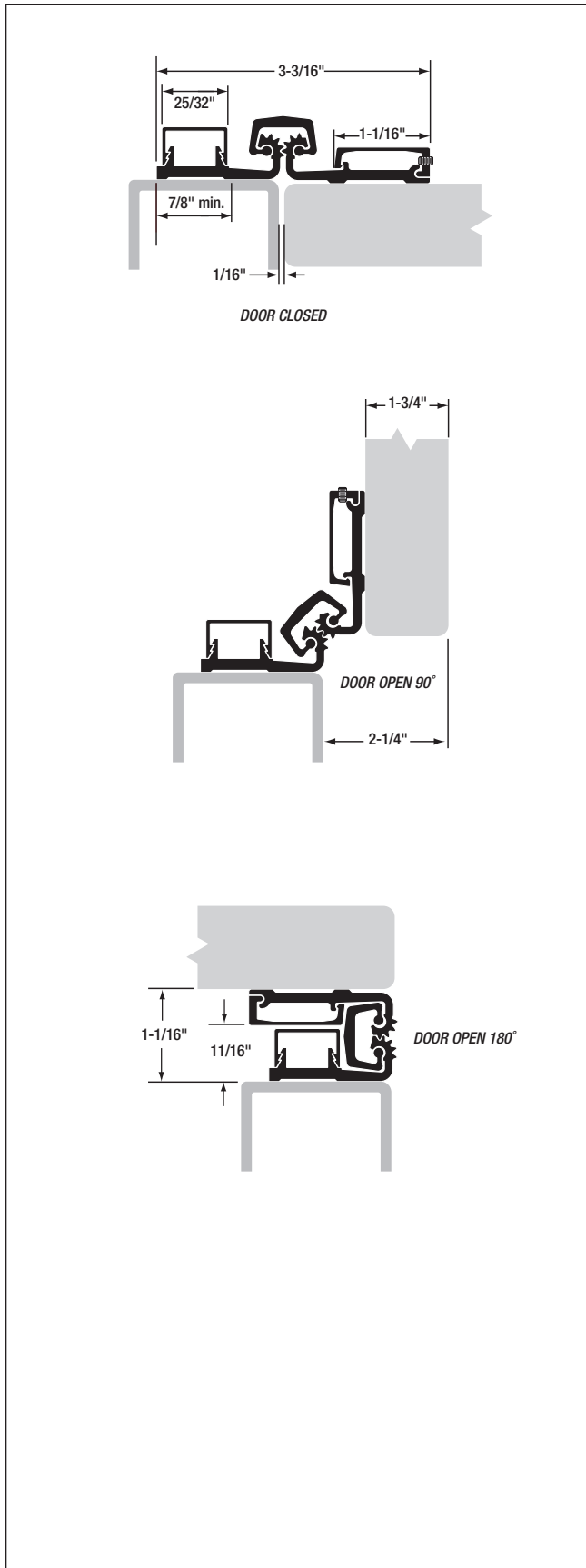
wedges and other tools in the Forced Entry Test. Approved for use in U.S. embassies overseas.

Geared to ship in 48 hours



SELECT ships hinges faster than anyone in the industry. 99.9% of our hinge orders ship in 48 hours; more than half are shipped in only 24 hours. Projects won't be delayed while waiting weeks for hinges.

NOTES:



MATERIAL: Extruded 6063 T6 aluminum alloy with self-lubricating polyester thrust bearings.

LENGTHS: 83", 85", 95" and 120" lengths standard for nominal door heights. Custom lengths are available.

LOAD/FREQUENCY RATINGS: For 1-3/8" – 1-3/4" doors standard; long barrel nuts available for 2" – 2-1/4" doors. 48" max. door width in 16 gauge hollow metal (min.) or 1/8" aluminum (min.).

Heavy Duty 300 – For high-frequency doors up to 300 lb. without frame or door reinforcement.

Heavy Duty 600 – For high-frequency doors up to 600 lb. Rivnuts are recommended in the frame when the door exceeds 450 lb.

FINISHES: All SL57 hinges are stocked in Clear, Dark Bronze and Black anodized aluminum. Custom anodized or painted finishes are available. Product painted or anodized in the field voids the SELECT hinge warranty.

CLOSERS: Conventional overhead surface, concealed sliding arm overhead or floor closers may be used with SELECT hinges. Pivot-type floor closers (with a fixed, conflicting center pivot) must be replaced.

ORDER: Specify length, finish and heavy duty 300 (HD300) or heavy duty 600 (HD600). Also, specify door and frame screw applications. 12-24 x 3/4" self-drilling, thread-forming 410SS Phillips undercut flathead screws, 1/4-20 through-bolts and 1/4-20 shoulder screws (for doors up to 1-3/4" thick) are provided as a standard pack unless otherwise specified. Wood and thread-forming screws also available. Security screws optional at extra cost.

AVAILABLE ELECTRIC PREPS: CTW4, CTW5, CTW8, CTW10, CTW12 and RP.



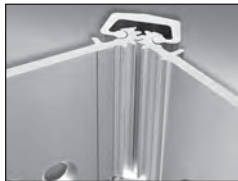
SL57 HINGE SCREW COUNT		
HINGE LENGTH & DUTY RATING	DOOR SCREWS	FRAME SCREWS
83" HD300/HD600	10	14
85" HD300/HD600	10	14
95" HD300/HD600	11	15
120" HD300/HD600	14	18

SELECT ADVANTAGES



PAIR-MATCHED™ HINGE LEAVES

Manufactured together, machined together and anodized together, making SELECT hinges fit your doors better and last longer. *An exclusive SELECT benefit.*



LIFETIME LUBRICATION

Eliminates the need for periodic maintenance. Quiet performance. Fights gear cap wear. *An exclusive SELECT benefit.*



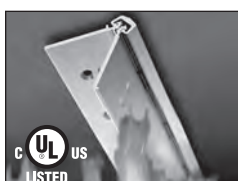
ANODIZED AFTER MACHINING

Delivers superior wear, durability and life. Inhibits corrosion. Few hinge makers follow SELECT's lead in using this superior manufacturing process.



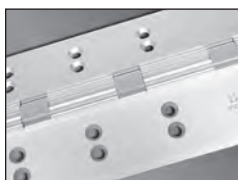
SUSTAINABLE

Made from up to 100% recycled aluminum. Reduces environmental impact and qualifies for LEED points. *An exclusive SELECT benefit.*



PATENTED 3-HR. FIRE RATING

Most SELECT hinges are fire rated for 90 minutes. 3-Hr. fire rating, optional at extra cost, approved for positive/negative pressure. No fire pins or studs required. Patented design innovation. *An exclusive SELECT benefit.*



CONSISTENT TEMPLATING

Hole pattern is identical on both Heavy Duty 300 and Heavy Duty 600 models, so SELECT hinges line up precisely for easier and faster installation. *An exclusive SELECT benefit.*



COATED FASTENERS

Provide additional corrosion protection with either self-drilling, thread-forming (SDTF) or thread-forming (TF) screws. *An exclusive SELECT benefit.*



CUSTOM COLORS

Match any paint color on the gear cap or the entire hinge and fasteners, including our always-in-stock Bone White gear caps. Anodized colors also available.

SELECT HINGE PERFORMANCE

- A SELECT geared continuous hinge has been tested in accordance with ANSI 250.4-1994 test procedure and acceptance criteria for physical endurance for steel doors and hardware and has surpassed 25,000,000 cycles during testing by an independent laboratory. On a door cycling 400,000 times per year, a SELECT hinge will be performing for over 62 years.
- SELECT geared continuous hinges are built to handle abuse from high-traffic applications. They are applied to the surface on the edge of the frame and door. No machining or reinforcement is required.
- The revolutionary SELECT geared continuous hinge puts an end to costly and irritating hinge failure problems, the most common cause of entrance failure.
- On conventional hinges, opening and “kick-back” energy concentrate on a few inches of fastened reinforcing plate — with the top hinge handling 100% of the force. Pinless SELECT hinges bond the door and frame into an integrated, sag-free unit. “Kick-back” energy dissipates along the entire length of the door and frame. (Compare this to a conventional hinge’s 4-1/2" to 5" at the top of the door and frame).
- SELECT geared continuous hinges eliminate the gap between the door and frame, providing a weatherproof, rust-proof, tamper-proof barrier. When the door is closed, there are no accessible screws, bolts or pins.
- SELECT SL57 geared continuous hinges are listed and tested by Underwriters Laboratories to meet the Positive and Negative pressure requirements of UL10B and UL10C, and are in accordance with UBC 7.2 (1997). SELECT SL57 geared continuous hinges are for use on swinging single fire doors (max. door opening of 4'x10') or pairs of fire doors (max. door opening of 8'x10'), including double egress, installed in masonry or drywall. SELECT SL57 geared continuous hinges are rated for up to 1-1/2 hours for wood composite and wood core type fire doors. A special patented process can be added to increase the fire rating to 3 hours (NO FIRE PINS OR STUDS REQUIRED) for hollow metal or steel covered composite type doors.

Concealed

SL200



SL300



SL305



SL315

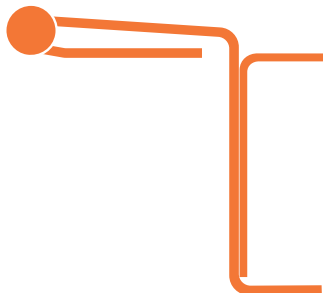


SL3500

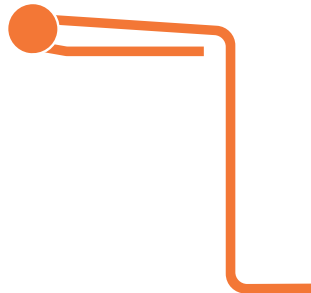


Swing Clear

SL310

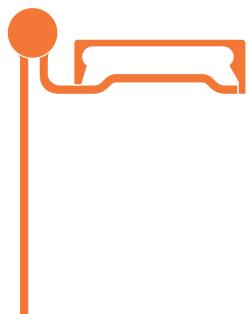


SL311



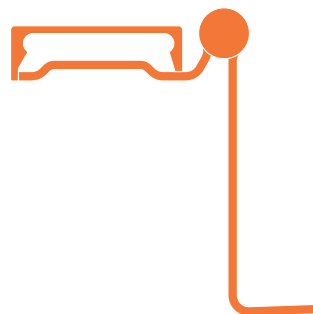
Half Surface

SL303



Half Mortise

SL306



Full Surface

SL302



SL309



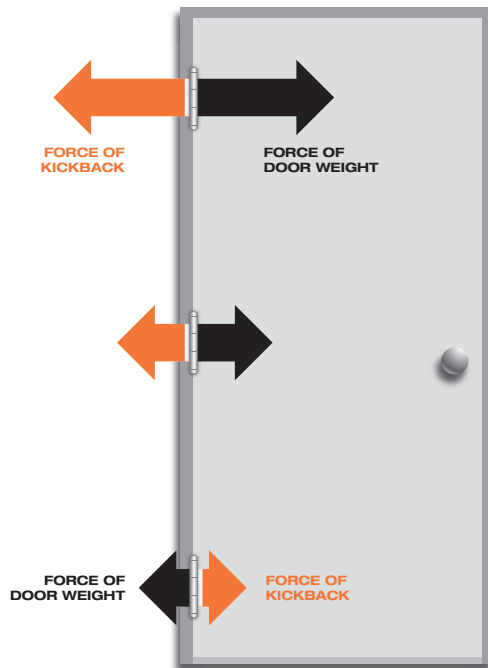
P&B CONTINUOUS HINGES

HINGE PART NUMBER INTERCHANGE: PIN & BARREL HINGES

SELECT MODELS	MARKAR	HAGER	PEMKO	MCKINNEY	STANLEY	ABH	IVES
SL200	FM-200			FM3700	641		600
SL300	FM-300	790-900	SPBFM	MCK FM300	651	A500	700
SL302	FS-302		SPBFS	MCK FS302	657	A502	702
SL303	HS-303	790-903	SPBHS	MCK HS303		A503	
SL305	HG-305	790-905	SPBFMDEG	MCK HG305	652	A505	705
SL306	HG-306	790-906		MCK HG306	655	A506	
SL309	FS/SC-309	790-909	SPBFSSC	MCK FS309			
SL310	HG-310			MCK HG310			
SL311	HG-311			MCK HG311	656	A511	711
SL315	HG-315		SPBFMEG				
SL3500	FM-3500		SPBFMHD				

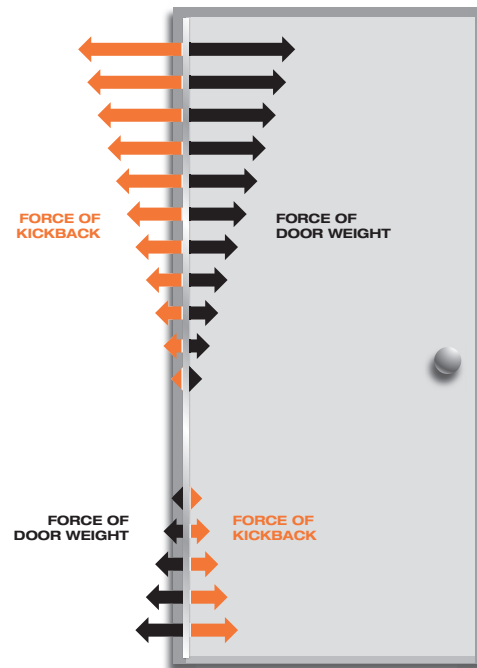
No equivalent hinge available from this manufacturer.

HINGE STRESS COMPARISON



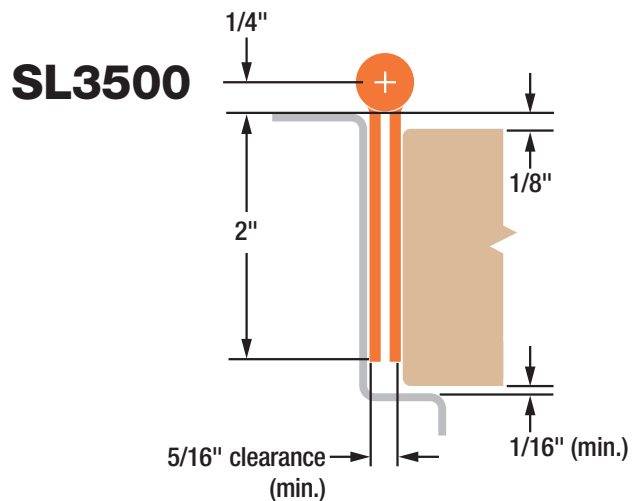
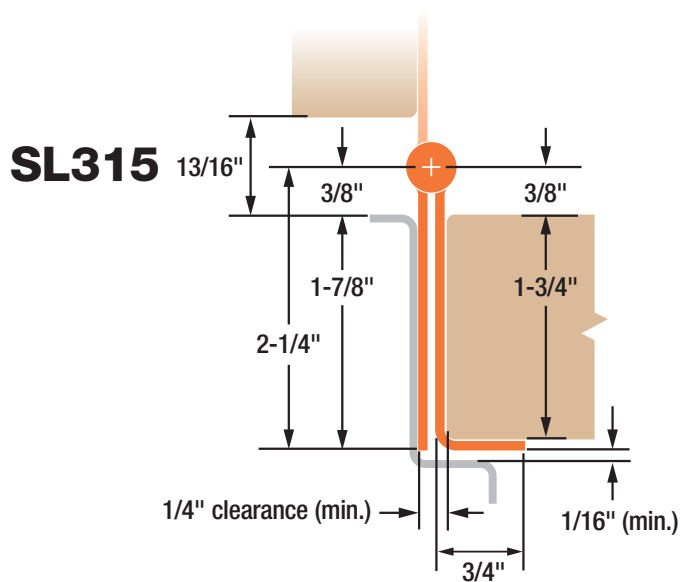
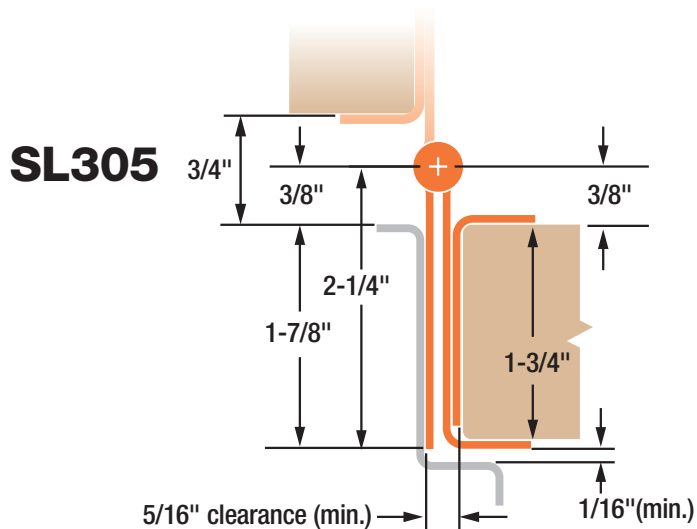
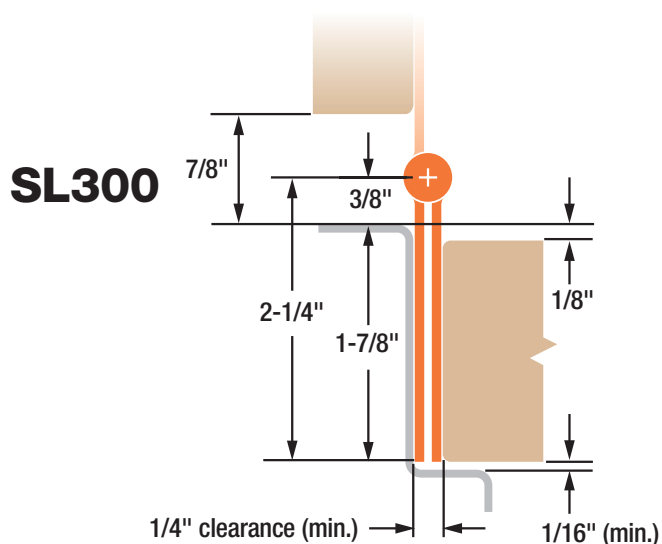
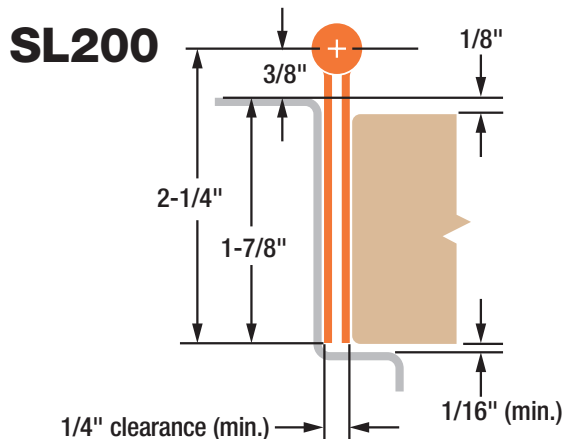
CONVENTIONAL BUTT HINGES

On conventional hinges, opening and “kickback” energy from closers and automatic operators concentrates on the top butt hinge. This force works against the top hinge, eventually forcing it apart or pulling it from the frame/door.



CONTINUOUS HINGES

SELECT continuous hinges unite the door and frame into an integrated, sag-free unit. “Kickback” energy dissipates along the entire length of the door and frame and prevents hinge failure.



CONCEALED P&B CONTINUOUS HINGES

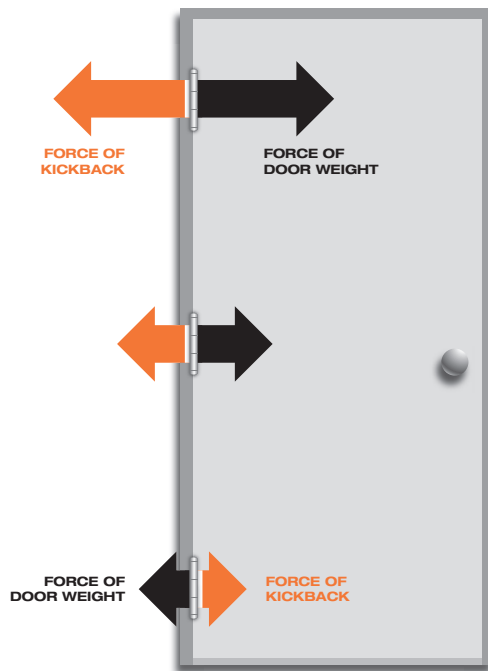


HINGE PART NUMBER INTERCHANGE: PIN & BARREL HINGES

SELECT MODELS	MARKAR	HAGER	PEMKO	MCKINNEY	STANLEY	ABH	IVES
SL200	FM-200			FM3700	641		600
SL300	FM-300	790-900	SPBFM	MCK FM300	651	A500	700
SL305	HG-305	790-905	SPBFMDEG	MCK HG305	652	A505	705
SL315	HG-315		SPBFMEG				
SL3500	FM-3500		SPBFMHD				

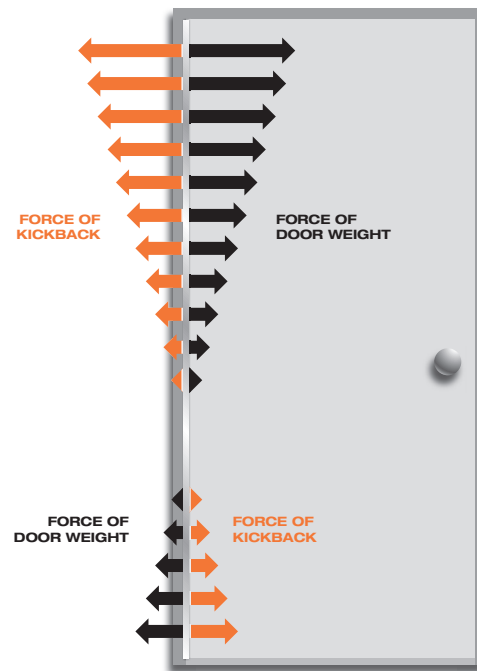
No equivalent hinge available from this manufacturer.

HINGE STRESS COMPARISON



CONVENTIONAL BUTT HINGES

On conventional hinges, opening and “kickback” energy from closers and automatic operators concentrates on the top butt hinge. This force works against the top hinge, eventually forcing it apart or pulling it from the frame/door.



CONTINUOUS HINGES

SELECT continuous hinges unite the door and frame into an integrated, sag-free unit. “Kickback” energy dissipates along the entire length of the door and frame and prevents hinge failure.

INSTALLATION INSTRUCTIONS

Concealed Pin and Barrel Continuous Hinges

SL200 & SL300



PRODUCT MUST BE INSTALLED ACCORDING TO ALL APPLICABLE BUILDING AND LIFE SAFETY CODES

All holes in door and frame must be drilled correctly and fasteners properly installed. Failure to use fasteners supplied by Select Products Limited will void UL or WHI fire rated listing.

Important Warranty Information:

The following actions will void any warranty, expressed or implied:

- Failure to install the hinge according to the manufacturer's specifications and requirements. (for more information, visit selecthingerequirements.com)
- Use of fasteners other than those supplied with the hinge.
- Unauthorized field modifications, including alteration of the original finish or painting the hinge.

1. Frame Preparation

- A. Place hinge frame leaf on rabbet. Position top of hinge 1/8" maximum below header (Fig. 1 & 2).
- B. Mark and center punch each hole on frame with hinge held firmly in place. Remove hinge. A center punch can help center hole so that fasteners will enter straight. Prepare to drill frame.

C. Drill holes:

Wood Frame: Drill holes using 5/32" drill bit.

Hollow Metal Frame: Drill holes using a #16 drill bit. If hollow metal frame is reinforced, thread all holes with #12-24 tap.

Do not install hinge to frame at this time.

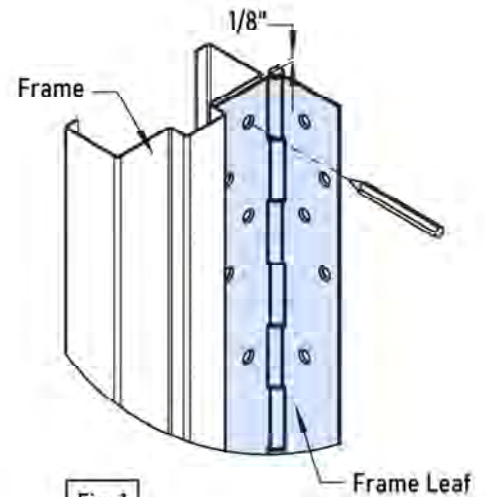


Fig. 1

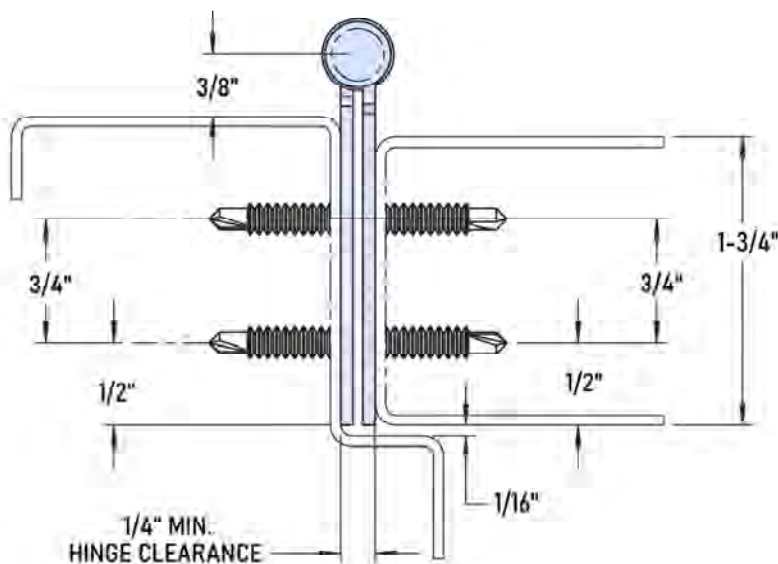


Fig. 2 HINGE PLACEMENT & CLEARANCE TEMPLATE

STANDARD HARDWARE	
#12-24 X 11/16" FLAT HEAD UNDERCUT SELF-DRILLING SCREW (TKS1267SP10SS)	
OPTIONAL HARDWARE AVAILABLE UPON REQUEST	
#12-8 x 1-1/2" FLAT HEAD UNDERCUT WOOD SCREW (PBS12150SP10SS)	
SECURITY SCREWPACKS M91-0031MM, M91-0031MW, M91-0031WW	

2. Door Preparation

- A. Position hinge door leaf so that top of hinge is flush with top of door. Make sure hinge edge is up flush with door face.
- B. Mark and center punch each hole on door with hinge held firmly in place (Fig 3). Remove hinge from door and prepare to drill door.

C. Drilling doors:

Wood Doors: Drill all holes using 5/32" drill bit.

Hollow Metal Doors: Drill all holes using a #16 drill bit
If hollow door is reinforced, thread all holes with #12-24 tap

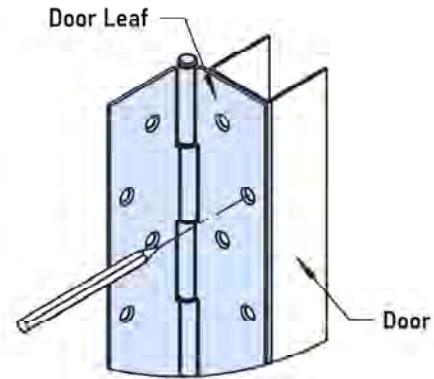


Fig. 3

3. Hinge Installation

A. Attaching hinge to door (Fig 4):

Wood: Attach hinge using #12-8 x 1-1/2" Flat Head Undercut Wood Screws

Hollow Metal: Attach hinge using #12-24 x 11/16" Flat Head Undercut Self-Drilling Screws

B. Attaching hinge to frame (Fig 5):

Wood: Attach hinge using #12-8 x 1-1/2" Flat Head Undercut Wood Screws

Hollow Metal: Attach hinge using #12-24 x 11/16" Flat Head Undercut Self-Drilling Screws

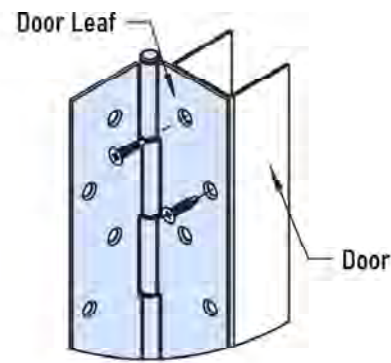


Fig. 4

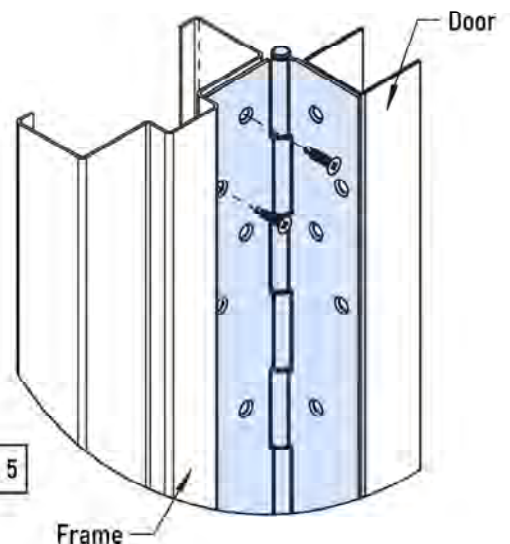
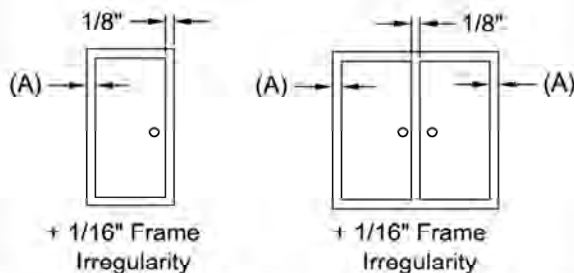


Fig. 5

Models SL200 and SL300

Standard "Non-Adjustable" application clearances

Door Edge	Clearance (A)	Total Under-Sizing Required	
		Single Door	Pair of Doors
Square	1/4"	7/16"	11/16"



SELECT HINGES

SELECT Products Limited

3258 Stadium Park Way
Kalamazoo, MI 49009
PH: 800-423-1174
Fax: 800-423-7107
www.select-hinges.com

H-02-17-08-20

INSTALLATION INSTRUCTIONS

Concealed Pin and Barrel Continuous Hinge

SL305



PRODUCT MUST BE INSTALLED ACCORDING TO ALL APPLICABLE BUILDING AND LIFE SAFETY CODES

All holes in door and frame must be drilled correctly and fasteners properly installed. Failure to use fasteners supplied by Select Products Limited will void UL or WHI fire rated listing.

Important Warranty Information:

The following actions will void any warranty, expressed or implied:

- Failure to install the hinge according to the manufacturer's specifications and requirements. (for more information, visit selecthingerequirements.com)
- Use of fasteners other than those supplied with the hinge.
- Unauthorized field modifications, including alteration of the original finish or painting the hinge.

1. Frame Preparation

A. Place hinge frame leaf on frame. Position top of hinge $1/8"$ maximum below header. Place hinge firmly against rabbet of frame (Fig. 1 & 2).

B. Mark and center punch each hole on frame with hinge held firmly in place. Remove hinge. A center punch can help center hole so that fasteners will enter straight. Prepare to drill frame.

C. Drill holes:

Wood Frame: Drill holes using $5/32"$ drill bit.

Hollow Metal Frame: Drill holes using a $\#16$ drill bit. If hollow metal frame is reinforced, thread all holes with $\#12-24$ tap.

Do not install hinge to frame at this time.

2. Door Preparation

A. Place hinge door leaf so that top of hinge is flush with top of door. Next, make sure return is up against door face.

B. Mark and center punch each hole on door with hinge held firmly in place (Fig. 3). Remove hinge from door and prepare to drill door.

C. Drilling doors:

Non Adjustable Hinge

Wood Doors: Drill all holes using $5/32"$ drill bit.

Hollow Metal Doors: Drill all holes using a $\#16$ drill bit. If hollow metal door is reinforced, thread all holes with $\#12-24$ tap.

Adjustable Hinge (if using Adjust-A-Screw™)

Wood Doors:

1. Drill all holes using a $5/32"$ drill bit then enlarge holes to $5/16"$ with a minimum depth of $1-3/8"$.
2. Insert Adjust-A-Screws into every hole.
3. Place a $7/32"$ Allen wrench in opening of Adjust-A-Screw and turn Adjust-A-Screw into hole while keeping screw properly aligned (Fig. 4).
4. Drive all Adjust-A-Screws in until approximately $1/8"$ from edge of door. (*Adjust-A-Screw will self-tap*)

Hollow Metal Doors:

1. Drill all holes using $\#16$ drill bit then enlarge holes with a $5/16"$ drill bit.
2. Thread all holes with $3/8-16$ tap.
3. Insert Adjust-A-Screws into every hole.
4. Place a $7/32"$ Allen wrench in opening of Adjust-A-Screw and turn Adjust-A-Screw into hole while keeping screw properly aligned (Fig. 4).
5. Drive all Adjust-A-Screws in until approximately $1/8"$ from edge of door.

Note: It is not necessary to tap holes in wood doors since Adjust-A-Screws cut their own threads. Do not be concerned with a tight fit. Adjust-A-Screws are designed for a tight friction fit in tapped holes so they will not turn when attachment screw is being tightened. If Adjust-A-Screw turns too freely, apply Loctite™ to threads during installation.

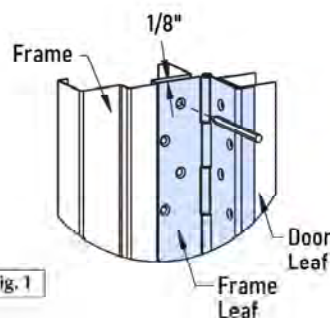


Fig. 1

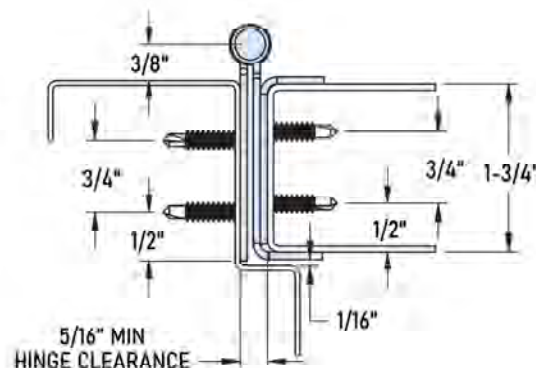


Fig. 2

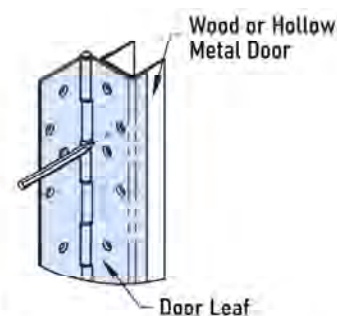


Fig. 3

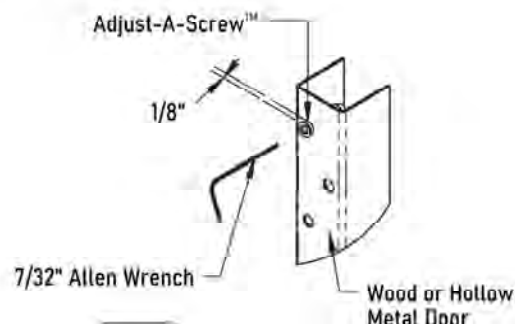


Fig. 4

3. Hinge Installation

A. Attaching hinge to door:

Peel backing from two-sided tape located on top and bottom of SL305 hinge guard. Properly align holes making sure return is up against door face and SL305 is flush with top of door. Stick guard to edge of door.

Non Adjustable Hinge (Fig. 5)

Wood: Attach hinge using #12-8 x 1-1/2" Flat Head Undercut Wood Screws

Hollow Metal: Attach hinge using #12-24 x 11/16" Flat Head Undercut Self-Drilling Screws

Adjustable Hinge (Fig. 6)

Wood & Hollow Metal: Attach hinge using #10-32 x 3/4" Flat Head Undercut Machine Screws

*Install top & bottom four screws first, then close door to check alignment
See Special Note Below:*

Special Note: If door is properly aligned, install and tighten remaining screws. If door requires alignment for proper fit, make this adjustment with four screws installed without removing the door. Remove one screw and insert Allen wrench through the hole into Adjust-A-Screw (Fig. 6). Turn Adjust-A-Screw in direction desired for adjustment. One full turn of the Allen wrench is equal to 1/16". Reinstall screw. Adjust remaining screws in same manner. Close door to verify door is aligned properly in opening. The balance of Adjust-A-Screws should be adjusted in same manner until are resting firmly against inside face of hinge. Then install and tighten remaining machine screws. Be sure adjustable angle is pressed firmly against face of door as screws are tightened.

B. Attaching hinge to frame (Fig. 7)

Wood: Attach hinge using #12-8 x 1-1/2" Flat Head Undercut Wood Screws

Hollow Metal: Attach hinge using #12-24 x 11/16" Flat Head Undercut Self-Drilling Screws

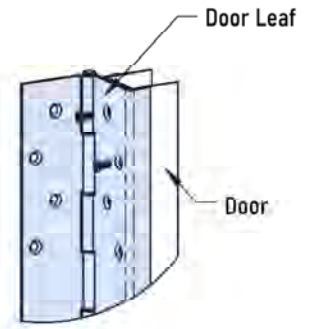


Fig. 5

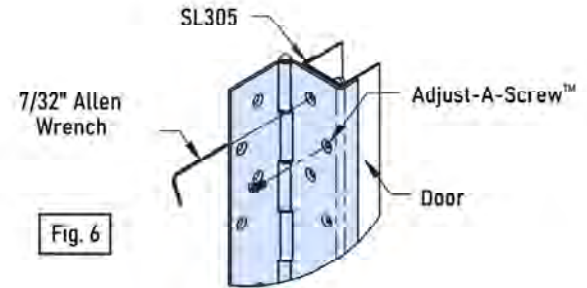


Fig. 6

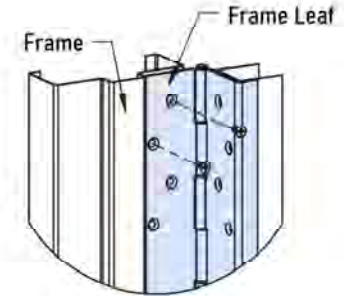


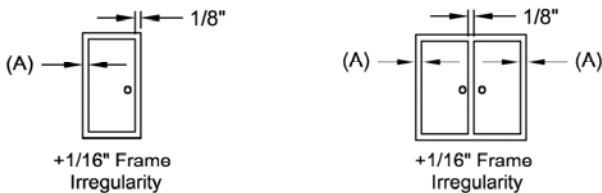
Fig. 7

Model SL305

Standard "Non-Adjustable" application clearances

Total Under-Sizing Required

Clearance (A)	Single Door	Pair of Doors
5/16"	1/2"	13/16"

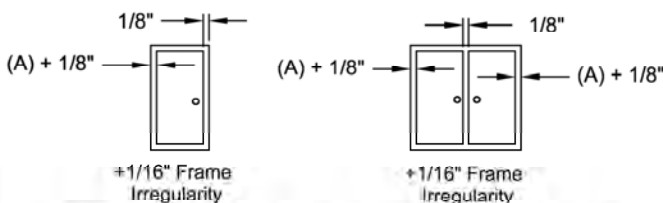


Model SL305

Standard "Adjustable" application clearances

Total Under-Sizing Required

Clearance (A)	Single Door	Pair of Doors
5/16"	5/8"	1-1/16"



NOTE: Proper door reinforcement is required for adjustable feature.

STANDARD HARDWARE



#12-24 X 11/16" FLAT HEAD UNDERCUT SELF-DRILLING SCREW (TKS1267SP10SS)

OPTIONAL HARDWARE AVAILABLE UPON REQUEST

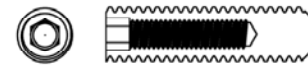


#12-8 X 1-1/2" FLAT HEAD UNDERCUT WOOD SCREW (PBS12750SP10SS)

ADJUSTABILITY HARDWARE



#10-32 X 3/4" FLAT HEAD UNDERCUT MACHINE SCREW (MS10075SS)



1-3/8" ADJUST-A-SCREW™ (M26-0031-01)

SECURITY SCREWPACKS M91-0031MM, M91-0031MW, M91-0031WW, M91-0002-630 M91-0032-630



SELECT HINGES

SELECT Products Limited

3258 Stadium Park Way
Kalamazoo, MI 49009
PH: 800-423-1174
Fax: 800-423-7107
www.select-hinges.com

INSTALLATION INSTRUCTIONS

Concealed Pin and Barrel Continuous Hinge SL315



PRODUCT MUST BE INSTALLED ACCORDING TO ALL APPLICABLE BUILDING AND LIFE SAFETY CODES

All holes in door and frame must be drilled correctly and fasteners properly installed. Failure to use fasteners supplied by Select Products Limited will void UL or WHI fire rated listing.

Important Warranty Information:

The following actions will void any warranty, expressed or implied:

- Failure to install the hinge according to the manufacturer's specifications and requirements. (for more information, visit selecthingerequirements.com)
- Use of fasteners other than those supplied with the hinge.
- Unauthorized field modifications, including alteration of the original finish or painting the hinge.

1. Frame Preparation

- A. Place hinge frame leaf on frame. Position top of hinge $1/8"$ maximum below header. Place hinge firmly against face of frame (Fig. 1 & 2).
- B. Mark and center punch each hole on frame with hinge held firmly in place. For ease of installation, center punch can help center hole so that fasteners will enter straight.
- C. Drill Holes:
Wood Frame: Drill holes using a $5/32"$ drill bit.
Hollow Metal Frame: Drill holes using a #16 drill bit.
 If hollow metal frame is reinforced, thread all holes with #12-24 tap.

Do not install hinge to frame at this time.

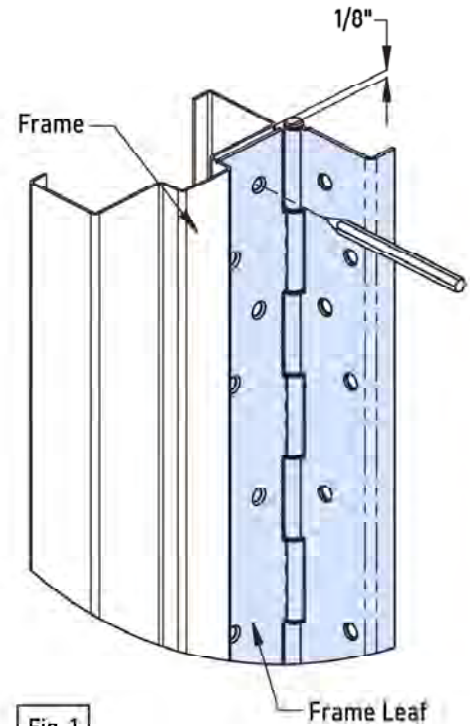


Fig. 1

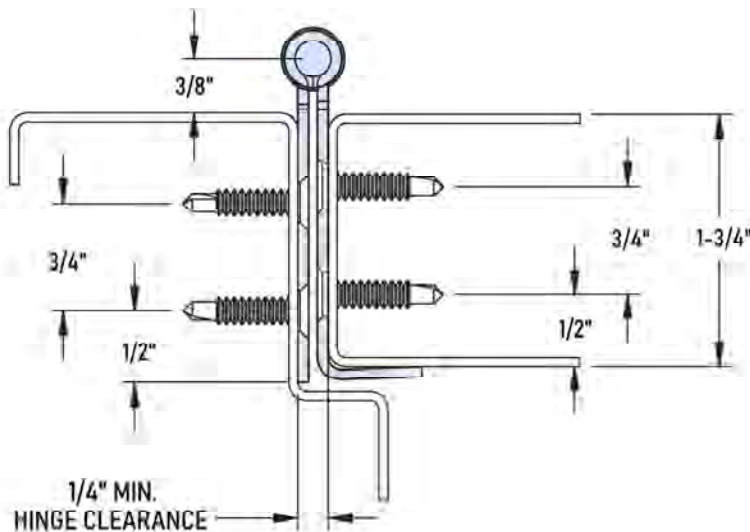






Fig. 2

STANDARD HARDWARE	
 	#12-24 X 1 1/16" FLAT HEAD UNDERCUT SELF-DRILLING SCREW (TKS1267SP10SS)
OPTIONAL HARDWARE AVAILABLE UPON REQUEST	
 	#12-8 x 1-1/2" FLAT HEAD UNDERCUT WOOD SCREW (PBS12150SP10SS)
SECURITY SCREWPACKS M91-0031MM, M91-0031MW, M91-0031WW	

2. Door Preparation

A. Place hinge door leaf on edge of door. Position top of hinge flush with top of door (Fig 3).

B. Mark and center punch each hole on door with hinge held firmly in place. Remove hinge from door and prepare to drill door.

C. Drilling Doors:

Wood Doors: Drill all holes using a 5/32" drill bit.

Hollow Metal Doors: Drill all holes using a #16 drill bit. If hollow metal door is reinforced, thread all holes with #12-24 tap.

3. Hinge Installation

A. Attaching hinge to door (Fig 4):

Wood: Attach hinge using #12-8 x 1-1/2" Flat Head Undercut Wood Screws

Hollow Metal: Attach hinge using #12-24 x 11/16" Flat Head Undercut Self-Drilling Screws

B. Attaching hinge to frame (Fig 5):

Wood: Attach hinge using #12-8 x 1-1/2" Flat Head Undercut Wood Screws

Hollow Metal: Attach hinge using #12-24 x 11/16" Flat Head Undercut Self-Drilling Screws

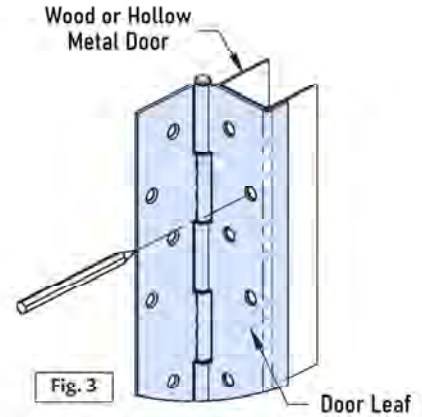


Fig. 3

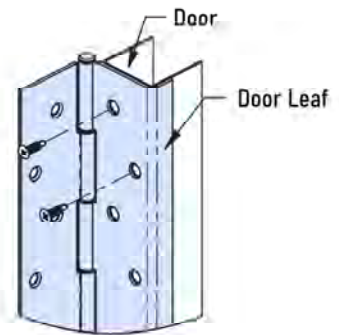


Fig. 4

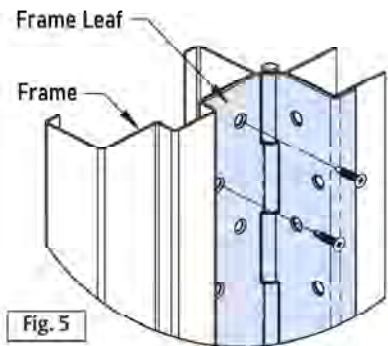


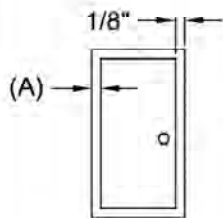
Fig. 5

Model SL315

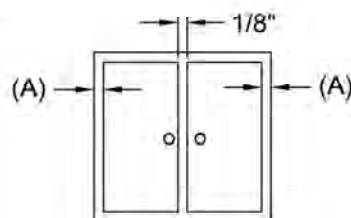
Standard "Non-Adjustable" application clearances

Total Under-Sizing Required

Door Edge	Clearance (A)	Single Door	Pair of Doors
Square	1/4"	7/16"	11/16"



+ 1/16" Frame Irregularity



+ 1/16" Frame Irregularity



SELECT HINGES®

SELECT Products Limited

3258 Stadium Park Way

Kalamazoo, MI 49009

PH: 800-423-1174

Fax: 800-423-7107

www.select-hinges.com

G-02-17-08-20

INSTALLATION INSTRUCTIONS

Concealed Pin and Barrel Continuous Hinge

SL3500



PRODUCT MUST BE INSTALLED ACCORDING TO ALL APPLICABLE BUILDING AND LIFE SAFETY CODES

All holes in door and frame must be drilled correctly and fasteners properly installed. Failure to use fasteners supplied by Select Products Limited will void UL or WHI fire rated listing.

Important Warranty Information:

The following actions will void any warranty, expressed or implied:

- Failure to install the hinge according to the manufacturer's specifications and requirements. (for more information, visit selecthingerequirements.com)
- Use of fasteners other than those supplied with the hinge.
- Unauthorized field modifications, including alteration of the original finish or painting the hinge.

1: Frame Preparation

- A. Place the hinge frame leaf on the frame. Position the top of the hinge 1/8" maximum below the header as shown (Fig.1). Place the hinge firmly against the rabbet of the frame.
- B. Mark and center punch each hole on the frame with the hinge held firmly in place. For ease of installation, a center punch can help center the hole so that the fasteners will enter straight. Remove the hinge from the frame and prepare to drill the frame.
- C. Drill holes:
Wood frame: Drill all holes using a #28 or 9/64" drill bit
Hollow Metal frame: Drill all holes using a #16 drill bit. If hollow metal frame is reinforced, thread all holes with #12-24 tap.

Do not attach the hinge to the frame at this time.

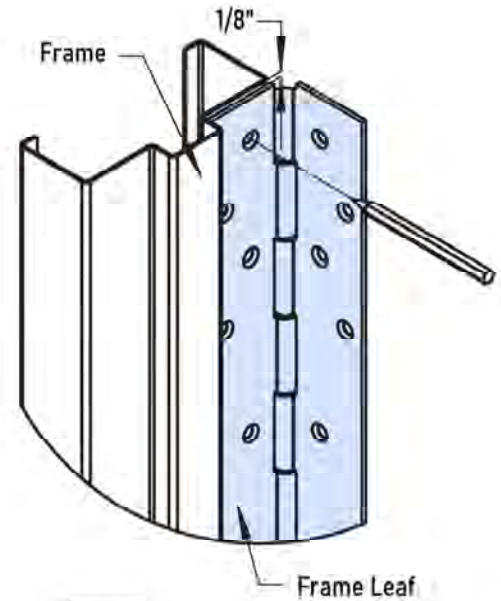


Fig. 1

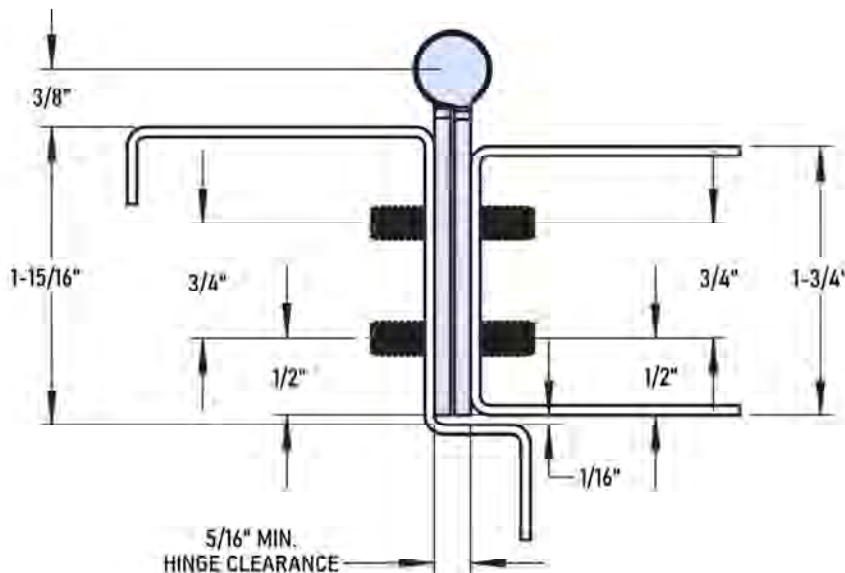


Fig. 2

STANDARD HARDWARE	
#12-24 X 7/16" FLAT HEAD UNDERCUT MACHINE SCREW (MS1244SP10SS)	
OPTIONAL HARDWARE AVAILABLE UPON REQUEST	
#12-8 x 1-1/2" FLAT HEAD UNDERCUT WOOD SCREW (PBS12150SP10SS)	
SECURITY SCREWPACKS M91-0031MM, M91-0031MW, M91-0031WW	

Step 2: Door Preparation

- A. Position the hinge door leaf so that the top of the hinge is flush with the top of the door. Next make sure the hinge edge is up flush with the door face.
- B. Mark and center punch each hole on the door with the hinge held firmly in place (Fig.2). Remove the hinge from the door and prepare to drill the door.
- C. Drill holes:

Wood Doors: Drill all holes using a #28 or 9/64" drill bit.

Hollow Metal Doors: Drill all holes using a #16 drill bit. If hollow metal door is reinforced, thread all holes with #12-24 tap.

Step 3: Hinge Installation

- A. Attaching hinge to door (Fig.3)
- Wood:** Attach hinge using #12-8 x 1-1/2" Flat Head Wood Screws
- Hollow Metal:** Attach hinge using #12-24 x 7/16" Flat Head Undercut Machine Screws

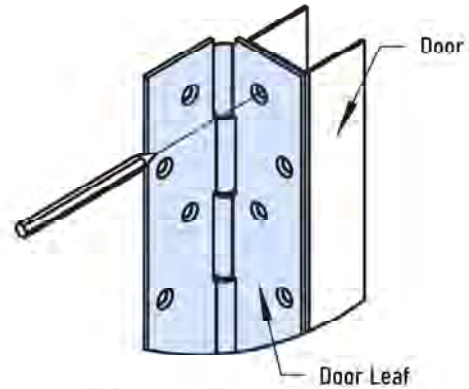


Fig. 3

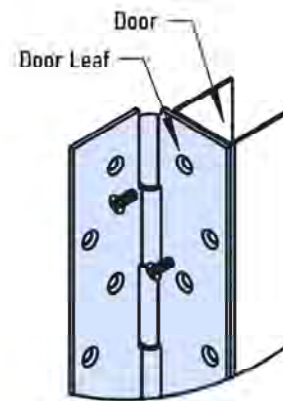


Fig. 4

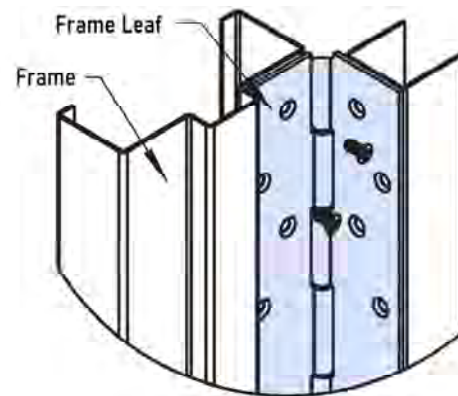


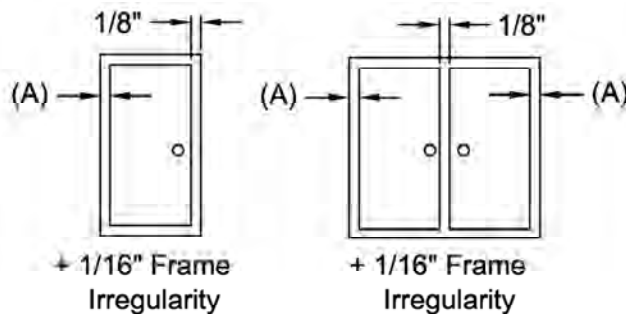
Fig. 5

Model SL3500

Standard "Non-Adjustable" application clearances

Total Under-Sizing Required

Door Edge	Clearance (A)	Single Door	Pair of Doors
Square	5/16"	1/2"	13/16"

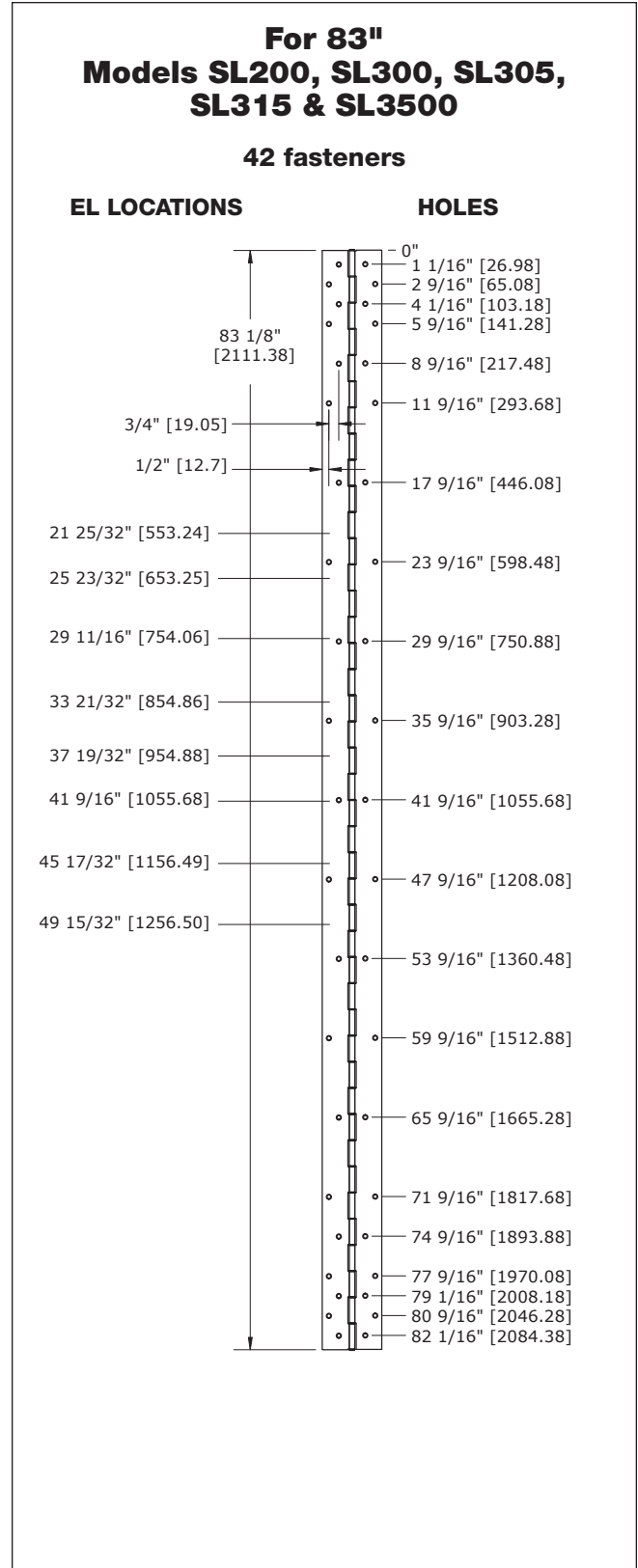
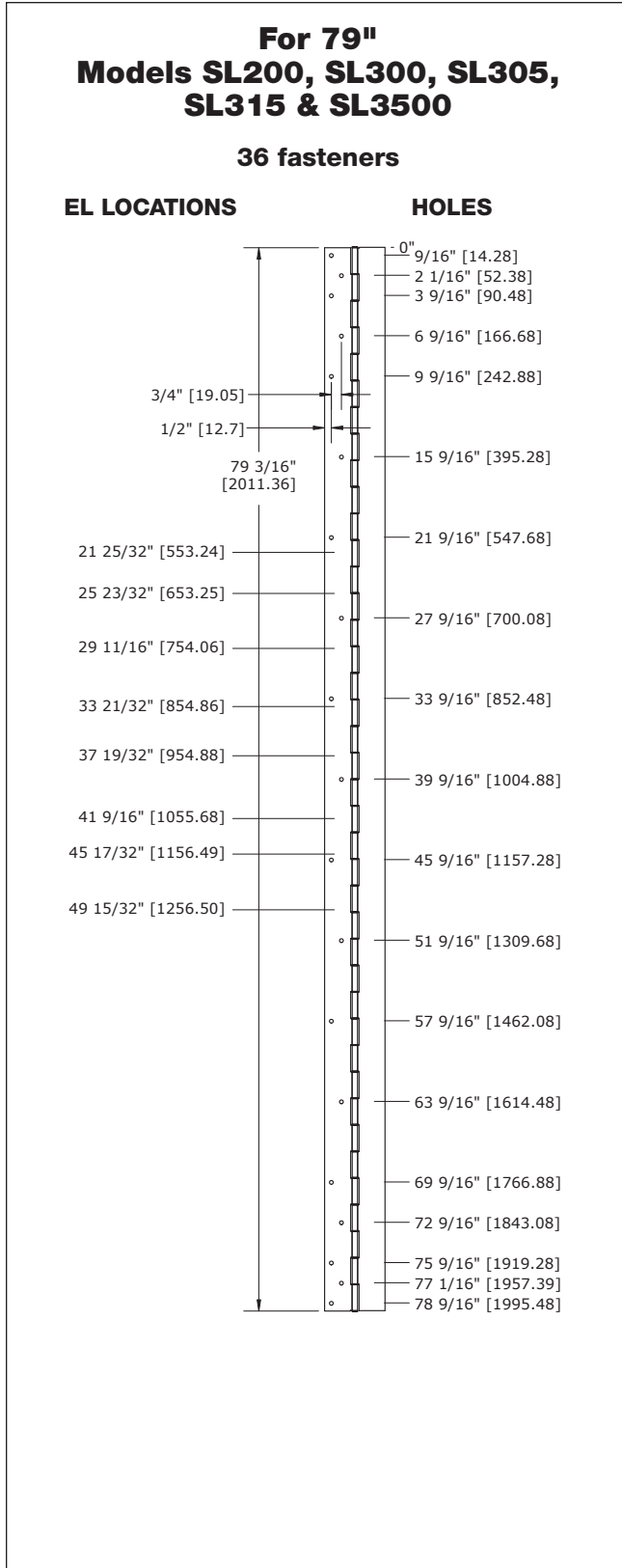


SELECT HINGES®
SELECT Products Limited

3258 Stadium Park Way
Kalamazoo, MI 49009
PH: 800-423-1174
Fax: 800-423-7107
www.select-hinges.com

F-02-17-08-20

- All dimensions are measured in inches and [millimeters] from the top of the door to the centerline of the holes.
- Choose location for EL prep from locations dimensioned.

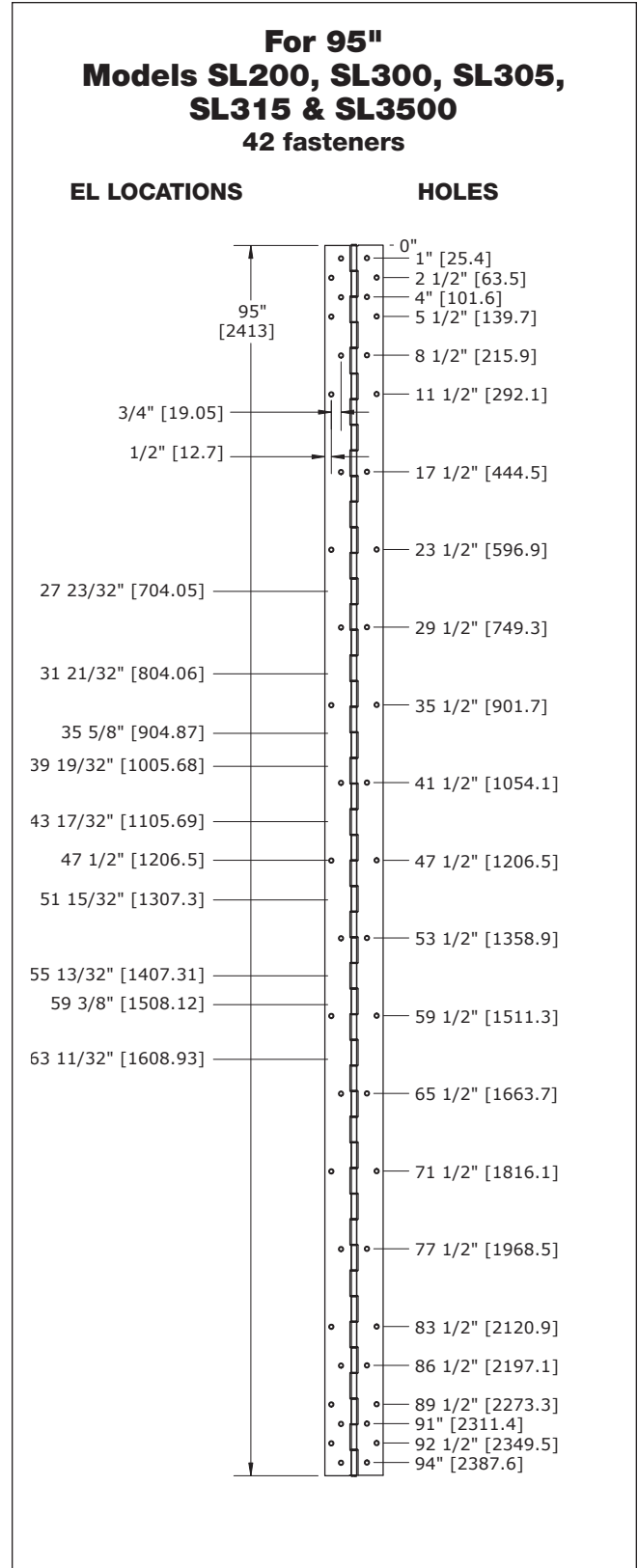
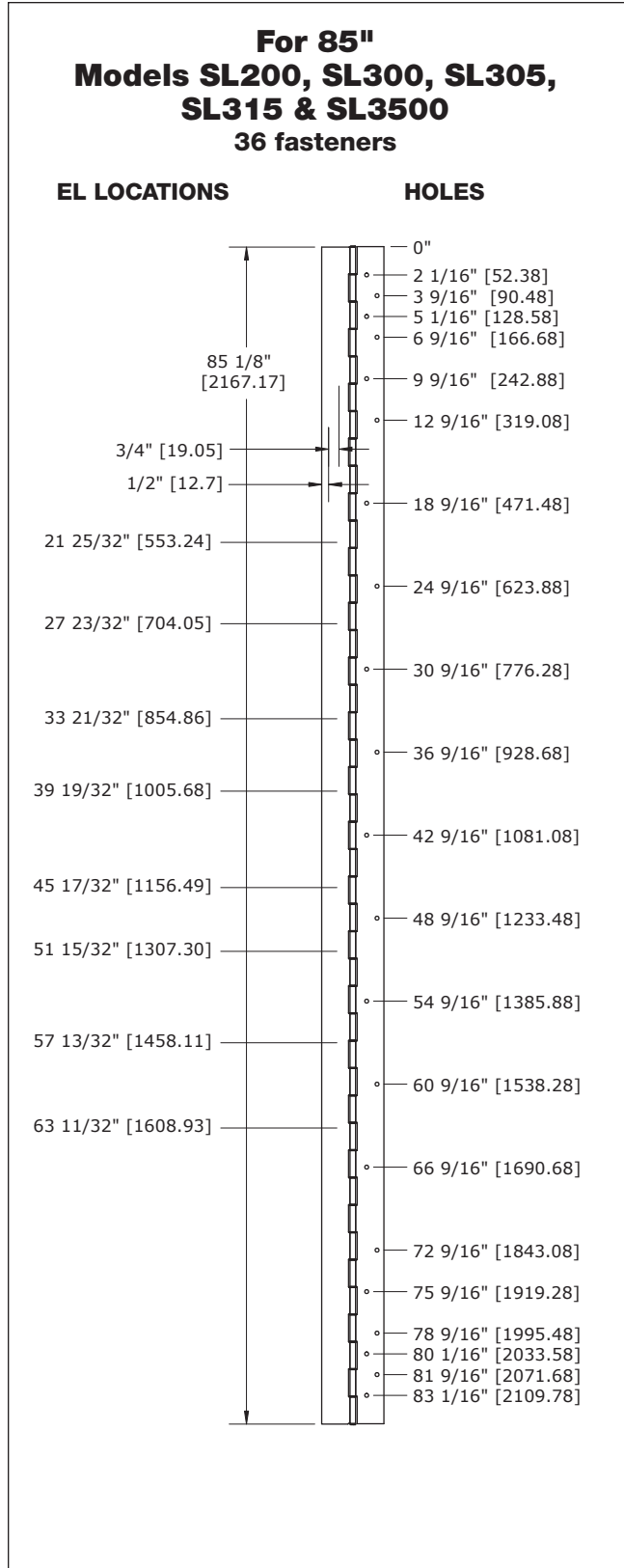


TEMPLATES

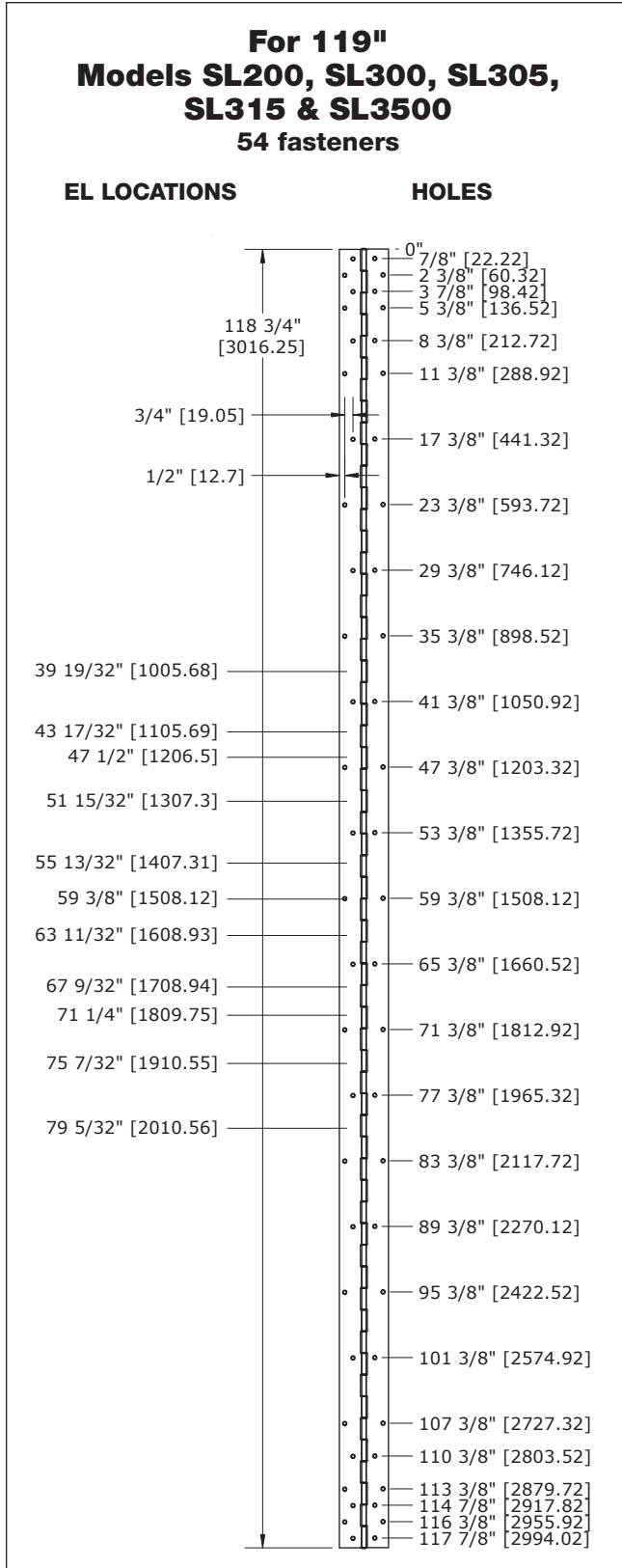
Concealed Pin & Barrel Hinges



- All dimensions are measured in inches and [millimeters] from the top of the door to the centerline of the holes.
- Choose location for EL prep from locations dimensioned.

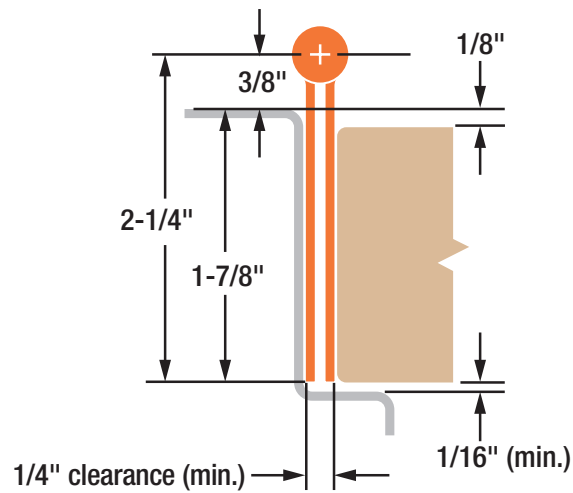


- All dimensions are measured in inches and [millimeters] from the top of the door to the centerline of the holes.
- Choose location for EL prep from locations dimensioned.





- Zinc plated carbon steel
- 1/8" door inset
- For 1-3/4" doors weighing up to 600 lb.
- 48" maximum door width



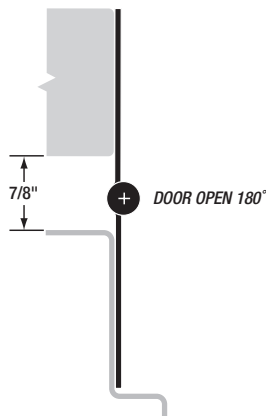
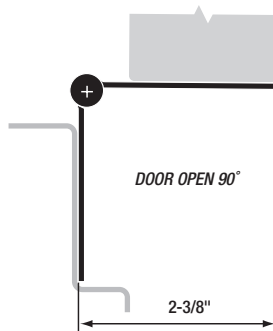
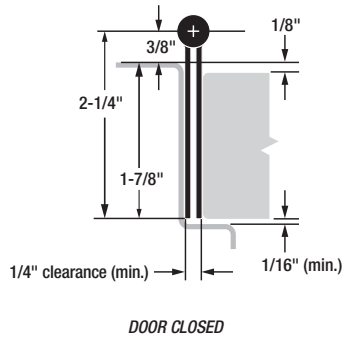
SL200

SL200 Concealed Pin & Barrel Continuous Hinge



SL200

NOTES:

SL200 Concealed Pin & Barrel Hinge


MATERIAL: 14 gauge 1012 cold-rolled steel with 3/16" diameter 304 stainless pin. Long-life nylon medical bearings.

LENGTHS: 79", 83", 85" and 95" lengths standard for nominal door heights. Custom lengths are available.

LOAD/FREQUENCY: For 1-3/4" doors, 48" wide (max.), weighing up to 400 pounds (medium-frequency) without frame or door reinforcement; up to 600 pounds (low-frequency) without frame or door reinforcement.

FINISH: Zinc plated carbon steel.

CLOSERS: Conventional overhead surface, concealed sliding arm overhead or floor closers may be used with SELECT hinges. Pivot-type floor closers (with a fixed, conflicting center pivot) must be replaced.

ORDER: Specify hinge length. Screw pack contains 12-24 x 7/8" zinc plated Phillips flathead undercut self-drilling Tek® screws and 10 x 1-1/4" zinc plated Phillips flathead undercut sheet metal screws.

AVAILABLE ELECTRIC PREPS: CTP-AR, CTP-VD, EL, AMS and ETAP.



SL200 HINGE SCREW COUNT		
HINGE LENGTH	DOOR SCREWS	FRAME SCREWS
79"	18	18
83"	21	21
85"	18	18
95"	23	23

SPECIFICATIONS

SL200 Concealed Pin & Barrel Hinge



SELECT ADVANTAGES



ZINC PLATED CARBON STEEL
Carbon steel with a stainless steel pin creates a tough, highly secure opening.



TEMPLATED HOLE PATTERN
SELECT hinges line up perfectly, precisely, every time. Makes installation easier and faster.



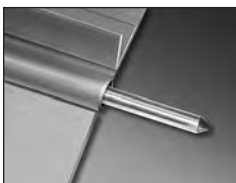
DUST-FREE (MEDICAL) BEARINGS
Prevent metal-to-metal contact and eliminate dust. Exclusive standard (no upcharge) on all SELECT Pin & Barrel hinges.



VARIETY OF FINISHES
Available in polished, brushed and painted finishes to match, contrast or accent your building's design.



3-HR. FIRE RATING
Fire-rated out of the package. No extra parts to buy or install. No liability worries.



STAINLESS STEEL PIN
Delivers high tensile strength by forming a strong, free-moving unit. Flexible and strong in abused openings.



END CAPS
Spiral-knurled steel caps seal the barrel ends to contain hinge pin.

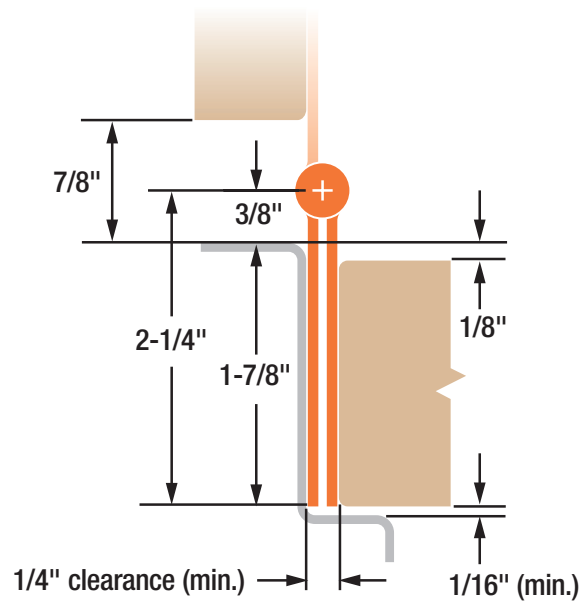
SELECT HINGE PERFORMANCE

- SELECT pin & barrel continuous hinges are built to handle abuse from high-traffic applications. They are applied to the surface on the edge of the frame and door. No machining or reinforcement is required.
- On conventional hinges, opening and “kick-back” energy concentrate on a few inches of fastened reinforcing plate — with the top hinge handling 100% of the force. Pinless SELECT hinges bond the door and frame into an integrated, sag-free unit. “Kick-back” energy dissipates along the entire length of the door and frame. (Compare this to a conventional hinge’s 4-1/2" to 5" at the top of the door and frame).
- SELECT pin & barrel continuous hinges eliminate the gap between the door and frame, providing a weatherproof, rust-proof, tamper-proof barrier.
- SELECT pin & barrel continuous hinges (excluding Toilet Partition hinges) are listed and tested by Underwriters Laboratories to meet the Positive pressure requirements of UL10C, and are in accordance with UBC 7.2 (1997). SELECT pin & barrel continuous hinges (excluding Toilet Partition hinges) are for use on swinging single fire doors (max. door opening of 4'x10') or pairs of fire doors (max. door opening of 8' x10'), including double egress, installed in masonry or drywall. SELECT pin & barrel continuous hinges (excluding Toilet Partition hinges) are rated for 20 minutes on labeled wood doors, 1-1/2 hours for labeled hollow metal and composite-core wood fire doors, and 3 hours (NO FIRE PINS OR STUDS REQUIRED) for labeled hollow metal doors mounted singly only.

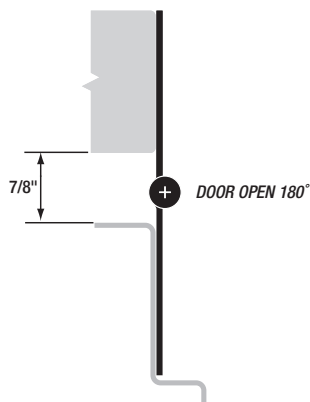
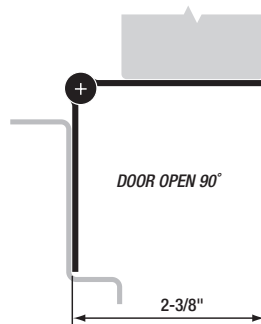
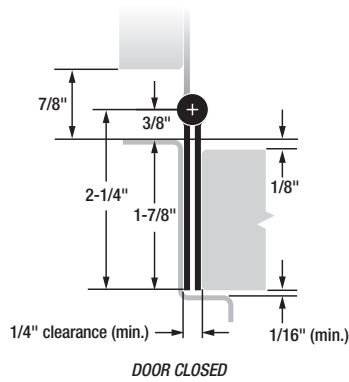




- Stainless steel
- 1/8" door inset
- For 1-3/4" doors weighing up to 600 lb.
- 48" maximum door width



SL300 Concealed Pin & Barrel Hinge



MATERIAL: 14 gauge 304 stainless steel with 3/16" diameter 304 stainless pin. Long-life nylon medical bearings.

LENGTHS: 79", 83", 85", 95" and 119" lengths standard for nominal door heights. Custom lengths are available.

LOAD/FREQUENCY: For 1-3/4" doors, 48" wide (max.), weighing up to 400 pounds (medium-frequency) without frame or door reinforcement; up to 600 pounds (low-frequency) without frame or door reinforcement.

FINISH: US32D satin stainless steel (630).

CLOSERS: Conventional overhead surface, concealed sliding arm overhead or floor closers may be used with SELECT hinges. Pivot-type floor closers (with a fixed, conflicting center pivot) must be replaced.

ORDER: Specify hinge length. Screw pack contains 12-24 x 7/8" 410SS Phillips flathead undercut self-drilling Tek® screws and 10 x 1-1/4" 410SS Phillips flathead undercut sheet metal screws.

AVAILABLE ELECTRIC PREPS: CTP-AR, CTP-VD, EL, AMS and ETAP.



SL300 HINGE SCREW COUNT		
HINGE LENGTH	DOOR SCREWS	FRAME SCREWS
79"	18	18
83"	21	21
85"	18	18
95"	23	23
119"	27	27

SPECIFICATIONS

SL300 Concealed Pin & Barrel Hinge



SELECT ADVANTAGES



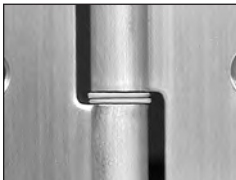
CORROSION-RESISTANT STAINLESS STEEL

Stainless steel pin & barrel design creates a tough, highly secure opening.



TEMPLATED HOLE PATTERN

SELECT hinges line up perfectly, precisely, every time. Makes installation easier and faster.



DUST-FREE (MEDICAL) BEARINGS

Prevent metal-to-metal contact and eliminate dust. Exclusive standard (no upcharge) on all SELECT Pin & Barrel hinges.



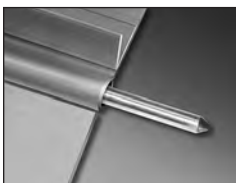
VARIETY OF FINISHES

Available in polished, brushed and painted finishes to match, contrast or accent your building's design.



3-HR. FIRE RATING

Fire-rated out of the package. No extra parts to buy or install. No liability worries.



STAINLESS STEEL PIN

Delivers high tensile strength by forming a strong, free-moving unit. Flexible and strong in abused openings.



END CAPS

Spiral-knurled steel caps seal the barrel ends to contain hinge pin.

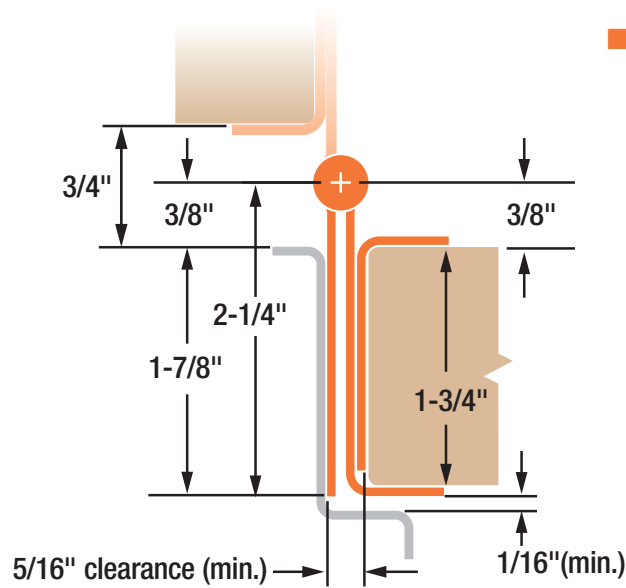
SELECT HINGE PERFORMANCE

- SELECT pin & barrel continuous hinges are built to handle abuse from high-traffic applications. They are applied to the surface on the edge of the frame and door. No machining or reinforcement is required.
- On conventional hinges, opening and “kick-back” energy concentrate on a few inches of fastened reinforcing plate — with the top hinge handling 100% of the force. Pinless SELECT hinges bond the door and frame into an integrated, sag-free unit. “Kick-back” energy dissipates along the entire length of the door and frame. (Compare this to a conventional hinge’s 4-1/2" to 5" at the top of the door and frame).
- SELECT pin & barrel continuous hinges eliminate the gap between the door and frame, providing a weatherproof, rust-proof, tamper-proof barrier.
- SELECT pin & barrel continuous hinges (excluding Toilet Partition hinges) are listed and tested by Underwriters Laboratories to meet the Positive pressure requirements of UL10C, and are in accordance with UBC 7.2 (1997). SELECT pin & barrel continuous hinges (excluding Toilet Partition hinges) are for use on swinging single fire doors (max. door opening of 4'x10') or pairs of fire doors (max. door opening of 8' x10'), including double egress, installed in masonry or drywall. SELECT pin & barrel continuous hinges (excluding Toilet Partition hinges) are rated for 20 minutes on labeled wood doors, 1-1/2 hours for labeled hollow metal and composite-core wood fire doors, and 3 hours (NO FIRE PINS OR STUDS REQUIRED) for labeled hollow metal doors mounted singly only.





- Stainless steel
- Door guard
- Universal Adjusta-Screw™ fasteners (right-hand thread) available at extra cost
- For 1-3/4" doors weighing up to 600 lb.
- 48" maximum door width



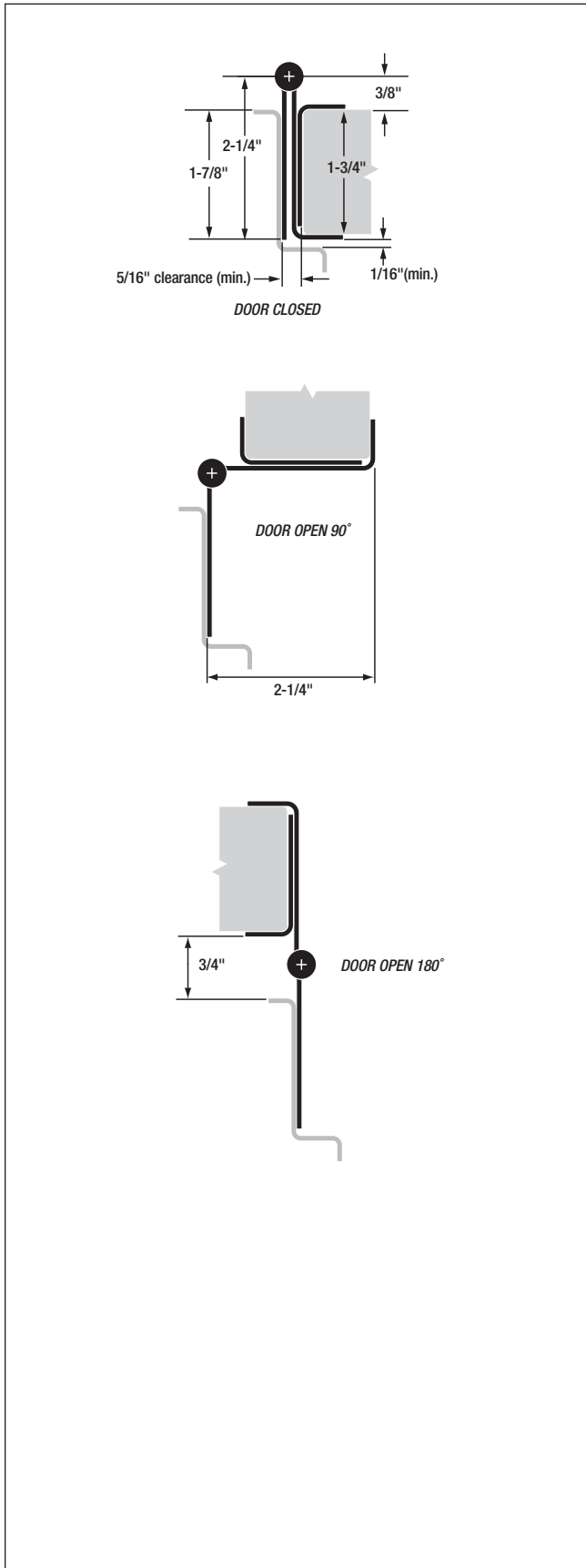
SL305 Concealed Pin & Barrel Continuous Hinge



SL305

NOTES:

SL305 Concealed Pin & Barrel Hinge



MATERIAL: 14 gauge 304 stainless steel with 3/16" diameter 304 stainless pin. Long-life nylon medical bearings.

LENGTHS: 79", 83", 85", 95" and 119" lengths standard for nominal door heights. Custom lengths are available.

LOAD/FREQUENCY: For 1-3/4" doors, 48" wide (max.), weighing up to 400 pounds (medium-frequency) without frame or door reinforcement; up to 600 pounds (low-frequency) without frame or door reinforcement.

FINISH: US32D satin stainless steel (630).

CLOSERS: Conventional overhead surface, concealed sliding arm overhead or floor closers may be used with SELECT hinges. Pivot-type floor closers (with a fixed, conflicting center pivot) must be replaced.

ORDER: Specify hinge length. Screw pack contains 10-24 x 7/8" 410SS Phillips flathead undercut self-drilling Tek® screws and 10 x 1-1/4" 410SS Phillips flathead undercut sheet metal screws. Adjusta-Screw™ fasteners available at extra cost.

AVAILABLE ELECTRIC PREPS: CTP-AR, CTP-VD, EL, AMS and ETAP.



SL305 HINGE SCREW COUNT		
HINGE LENGTH	DOOR SCREWS	FRAME SCREWS
79"	18	18
83"	21	21
85"	18	18
95"	23	23
119"	27	27

SPECIFICATIONS

SL305 Concealed Pin & Barrel Hinge



SELECT ADVANTAGES



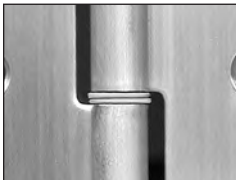
CORROSION-RESISTANT STAINLESS STEEL

Stainless steel pin & barrel design creates a tough, highly secure opening.



TEMPLATED HOLE PATTERN

SELECT hinges line up perfectly, precisely, every time. Makes installation easier and faster.



DUST-FREE (MEDICAL) BEARINGS

Prevent metal-to-metal contact and eliminate dust. Exclusive standard (no upcharge) on all SELECT Pin & Barrel hinges.



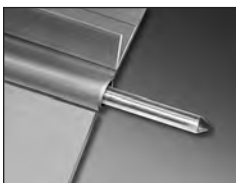
VARIETY OF FINISHES

Available in polished, brushed and painted finishes to match, contrast or accent your building's design.



3-HR. FIRE RATING

Fire-rated out of the package. No extra parts to buy or install. No liability worries.



STAINLESS STEEL PIN

Delivers high tensile strength by forming a strong, free-moving unit. Flexible and strong in abused openings.



END CAPS

Spiral-knurled steel caps seal the barrel ends to contain hinge pin.



ADJUSTA-SCREW™ FASTENERS

Remedy out-of-square doors and frames easily. Correct fit variances up to 3/8" along full length of door. Available at extra cost.

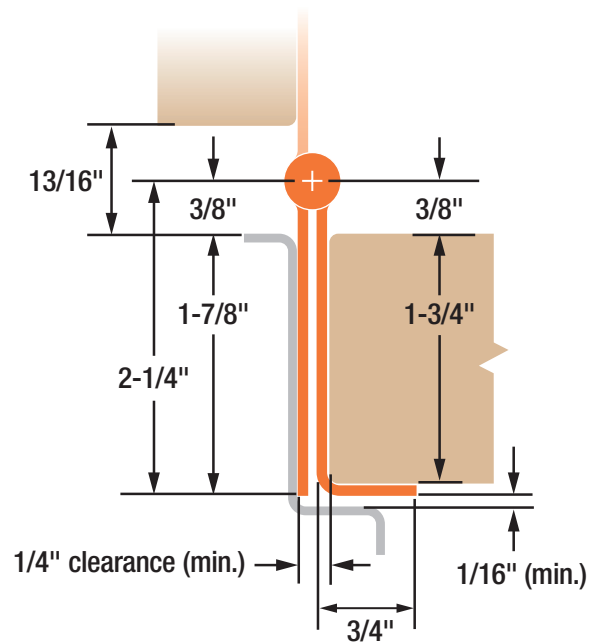
SELECT HINGE PERFORMANCE

- SELECT pin & barrel continuous hinges are built to handle abuse from high-traffic applications. They are applied to the surface on the edge of the frame and door. No machining or reinforcement is required.
- On conventional hinges, opening and “kick-back” energy concentrate on a few inches of fastened reinforcing plate — with the top hinge handling 100% of the force. Pinless SELECT hinges bond the door and frame into an integrated, sag-free unit. “Kick-back” energy dissipates along the entire length of the door and frame. (Compare this to a conventional hinge’s 4-1/2" to 5" at the top of the door and frame).
- SELECT pin & barrel continuous hinges eliminate the gap between the door and frame, providing a weatherproof, rust-proof, tamper-proof barrier.
- SELECT pin & barrel continuous hinges (excluding Toilet Partition hinges) are listed and tested by Underwriters Laboratories to meet the Positive pressure requirements of UL10C, and are in accordance with UBC 7.2 (1997). SELECT pin & barrel continuous hinges (excluding Toilet Partition hinges) are for use on swinging single fire doors (max. door opening of 4'x10') or pairs of fire doors (max. door opening of 8' x10'), including double egress, installed in masonry or drywall. SELECT pin & barrel continuous hinges (excluding Toilet Partition hinges) are rated for 20 minutes on labeled wood doors, 1-1/2 hours for labeled hollow metal and composite-core wood fire doors, and 3 hours (NO FIRE PINS OR STUDS REQUIRED) for labeled hollow metal doors mounted singly only.





- Stainless steel
- Edge guard
- For 1-3/4" doors weighing up to 600 lb.
- 48" maximum door width



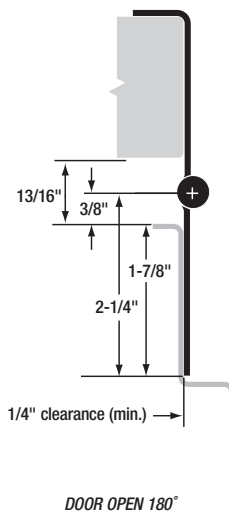
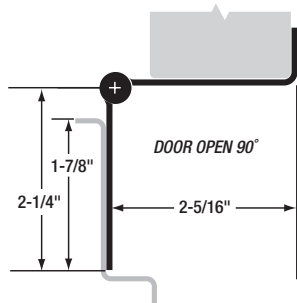
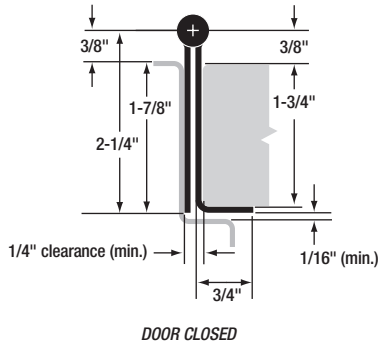
SL315
Concealed Pin & Barrel Continuous Hinge



SL315

NOTES:

SL315 Concealed Pin & Barrel Hinge



MATERIAL: 14 gauge 304 stainless steel with 3/16" diameter 304 stainless pin. Long-life nylon medical bearings.

LENGTHS: 79", 83", 85", 95" and 119" lengths standard for nominal door heights. Custom lengths are available.

LOAD/FREQUENCY: For 1-3/4" doors, 48" wide (max.), weighing up to 400 pounds (medium-frequency) without frame or door reinforcement; up to 600 pounds (low-frequency) without frame or door reinforcement.

FINISH: US32D satin stainless steel (630).

CLOSERS: Conventional overhead surface, concealed sliding arm overhead or floor closers may be used with SELECT hinges. Pivot-type floor closers (with a fixed, conflicting center pivot) must be replaced.

ORDER: Specify hinge length. Screw pack contains 12-24 x 7/8" 410SS Phillips flathead undercut self-drilling Tek® screws and 10 x 1-1/4" 410SS Phillips flathead undercut sheet metal screws.

AVAILABLE ELECTRIC PREPS: CTP-AR, CTP-VD, EL, AMS and ETAP.



SL315 HINGE SCREW COUNT

HINGE LENGTH	DOOR SCREWS	FRAME SCREWS
79"	18	18
83"	21	21
85"	18	18
95"	23	23
119"	27	27

SPECIFICATIONS

SL315 Concealed Pin & Barrel Hinge



SELECT ADVANTAGES



CORROSION-RESISTANT STAINLESS STEEL

Stainless steel pin & barrel design creates a tough, highly secure opening.



TEMPLATED HOLE PATTERN

SELECT hinges line up perfectly, precisely, every time. Makes installation easier and faster.



DUST-FREE (MEDICAL) BEARINGS

Prevent metal-to-metal contact and eliminate dust. Exclusive standard (no upcharge) on all SELECT Pin & Barrel hinges.



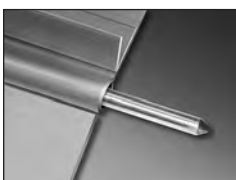
VARIETY OF FINISHES

Available in polished, brushed and painted finishes to match, contrast or accent your building's design.



3-HR. FIRE RATING

Fire-rated out of the package. No extra parts to buy or install. No liability worries.



STAINLESS STEEL PIN

Delivers high tensile strength by forming a strong, free-moving unit. Flexible and strong in abused openings.



END CAPS

Spiral-knurled steel caps seal the barrel ends to contain hinge pin.

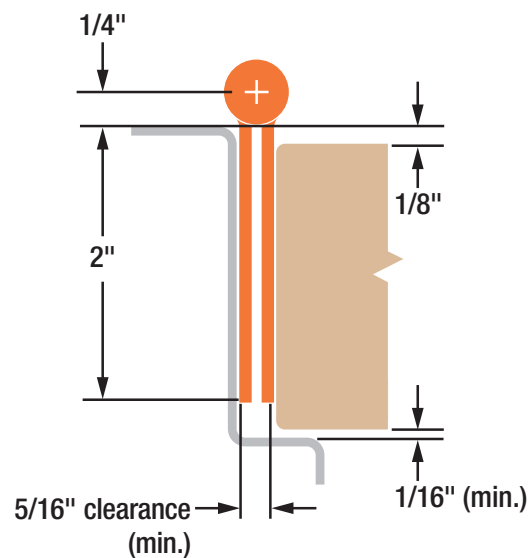
SELECT HINGE PERFORMANCE

- SELECT pin & barrel continuous hinges are built to handle abuse from high-traffic applications. They are applied to the surface on the edge of the frame and door. No machining or reinforcement is required.
- On conventional hinges, opening and “kick-back” energy concentrate on a few inches of fastened reinforcing plate — with the top hinge handling 100% of the force. Pinless SELECT hinges bond the door and frame into an integrated, sag-free unit. “Kick-back” energy dissipates along the entire length of the door and frame. (Compare this to a conventional hinge’s 4-1/2" to 5" at the top of the door and frame).
- SELECT pin & barrel continuous hinges eliminate the gap between the door and frame, providing a weatherproof, rust-proof, tamper-proof barrier.
- SELECT pin & barrel continuous hinges (excluding Toilet Partition hinges) are listed and tested by Underwriters Laboratories to meet the Positive pressure requirements of UL10C, and are in accordance with UBC 7.2 (1997). SELECT pin & barrel continuous hinges (excluding Toilet Partition hinges) are for use on swinging single fire doors (max. door opening of 4'x10') or pairs of fire doors (max. door opening of 8' x10'), including double egress, installed in masonry or drywall. SELECT pin & barrel continuous hinges (excluding Toilet Partition hinges) are rated for 20 minutes on labeled wood doors, 1-1/2 hours for labeled hollow metal and composite-core wood fire doors, and 3 hours (NO FIRE PINS OR STUDS REQUIRED) for labeled hollow metal doors mounted singly only.





- Extra-heavy duty
12 gauge stainless steel
- Meets ASTM F1450A
Abuse Test requirements
- Hospital Tip Prep standard
- Torx® head security
fasteners available at
extra cost
- 1/8" door inset
- For 1-3/4" to 2-1/4" doors
weighing up to 900 lb.
- 48" maximum door width

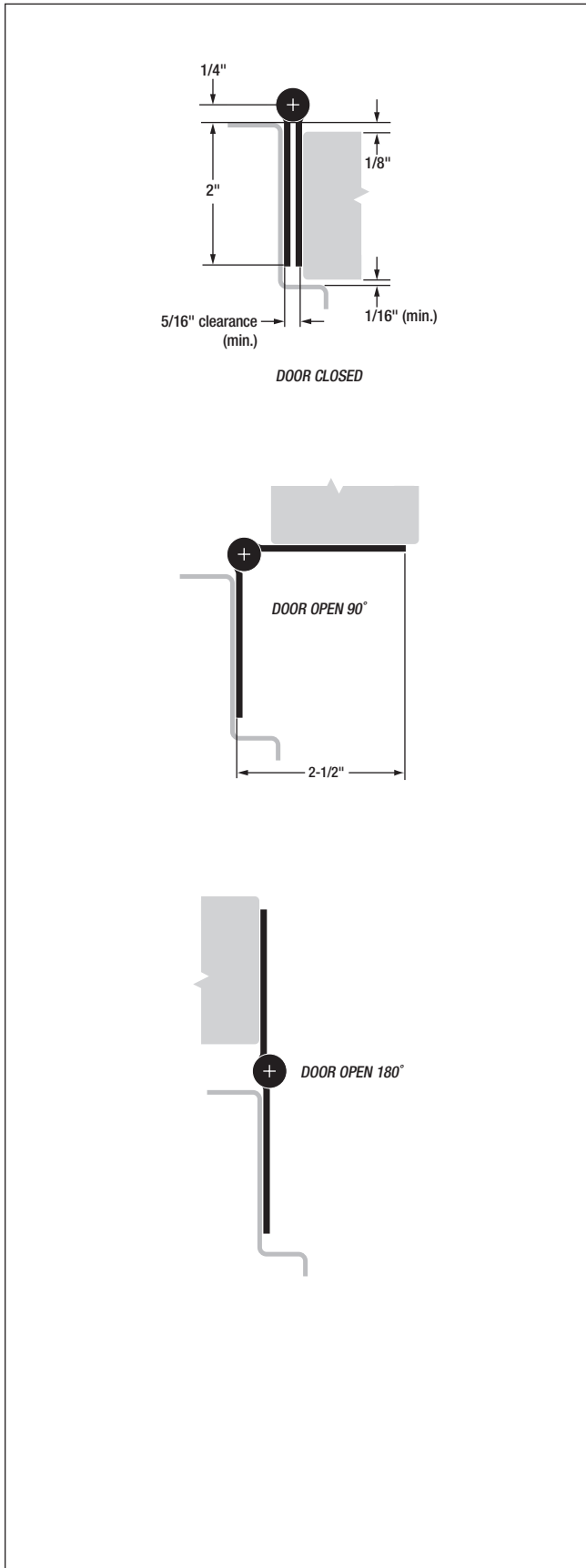


SL3500
Concealed Pin & Barrel Continuous Hinge



SL3500

NOTES:

SL3500 Concealed Pin & Barrel Hinge


MATERIAL: 12 gauge 304 stainless steel with 3/16" diameter 304 stainless pin. Long-life nylon medical bearings.

LENGTHS: 79", 83", 85", 95" and 119" lengths standard for nominal door heights. Custom lengths are available.

LOAD/FREQUENCY: For 1-3/4"–2-1/4" doors, 48" wide (max.), weighing up to 900 pounds with frame and door reinforcement.

FINISH: US32D satin stainless steel (630).

CLOSERS: Conventional overhead surface, concealed sliding arm overhead or floor closers may be used with SELECT hinges. Pivot-type floor closers (with a fixed, conflicting center pivot) must be replaced.

ORDER: Specify hinge length. Screw pack contains 12-24 x 1/2" stainless steel Phillips flathead undercut machine screws. Torx® head security fasteners available at extra cost.


SL3500 HINGE SCREW COUNT

HINGE LENGTH	DOOR SCREWS	FRAME SCREWS
79"	18	18
83"	21	21
85"	18	18
95"	23	23
119"	27	27

SPECIFICATIONS

SL3500 Concealed Pin & Barrel Hinge



SELECT ADVANTAGES



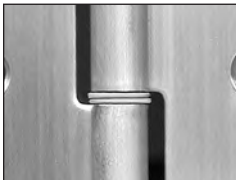
CORROSION-RESISTANT STAINLESS STEEL

Stainless steel pin & barrel design creates a tough, highly secure opening.



TEMPLATED HOLE PATTERN

SELECT hinges line up perfectly, precisely, every time. Makes installation easier and faster.



DUST-FREE (MEDICAL) BEARINGS

Prevent metal-to-metal contact and eliminate dust. Exclusive standard (no upcharge) on all SELECT Pin & Barrel hinges.



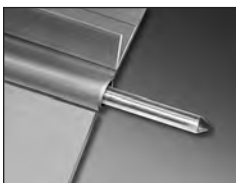
VARIETY OF FINISHES

Available in polished, brushed and painted finishes to match, contrast or accent your building's design.



3-HR. FIRE RATING

Fire-rated out of the package. No extra parts to buy or install. No liability worries.



STAINLESS STEEL PIN

Delivers high tensile strength by forming a strong, free-moving unit. Flexible and strong in abused openings.



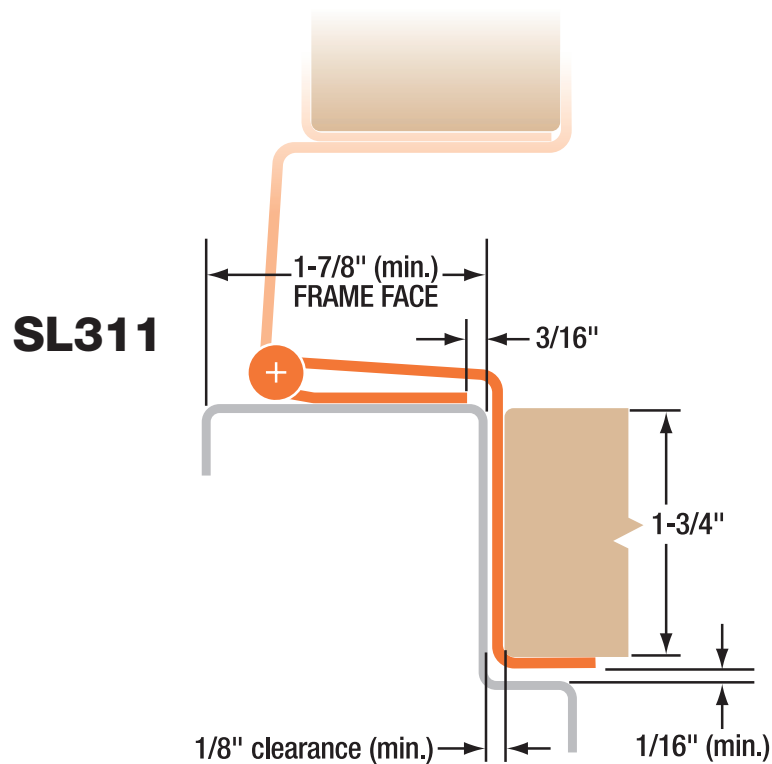
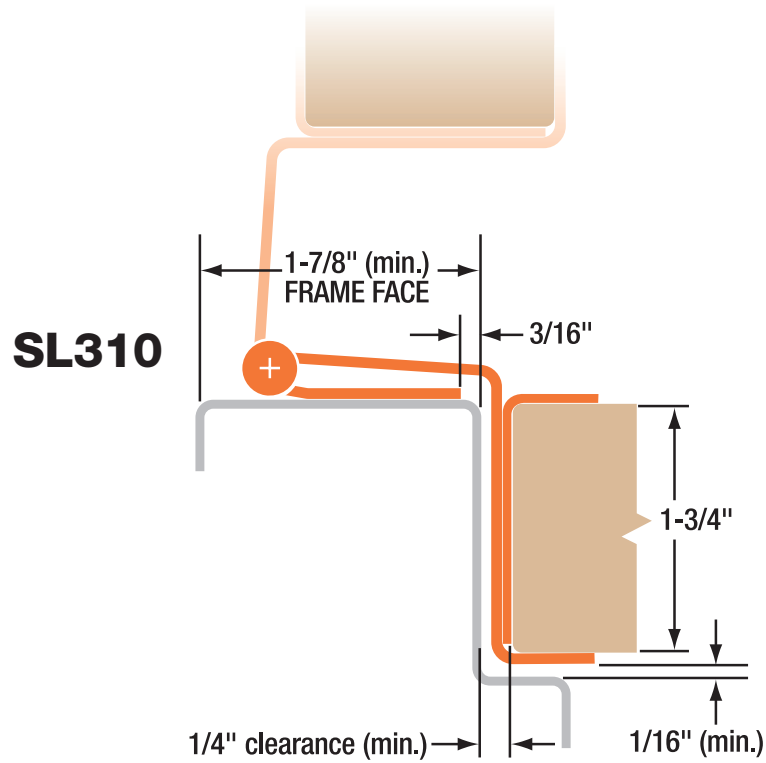
END CAPS

Spiral-knurled steel caps seal the barrel ends to contain hinge pin.

SELECT HINGE PERFORMANCE

- SELECT pin & barrel continuous hinges are built to handle abuse from high-traffic applications. They are applied to the surface on the edge of the frame and door. No machining or reinforcement is required.
- On conventional hinges, opening and “kick-back” energy concentrate on a few inches of fastened reinforcing plate — with the top hinge handling 100% of the force. Pinless SELECT hinges bond the door and frame into an integrated, sag-free unit. “Kick-back” energy dissipates along the entire length of the door and frame. (Compare this to a conventional hinge’s 4-1/2" to 5" at the top of the door and frame).
- SELECT pin & barrel continuous hinges eliminate the gap between the door and frame, providing a weatherproof, rust-proof, tamper-proof barrier.
- SELECT pin & barrel continuous hinges (excluding Toilet Partition hinges) are listed and tested by Underwriters Laboratories to meet the Positive pressure requirements of UL10C, and are in accordance with UBC 7.2 (1997). SELECT pin & barrel continuous hinges (excluding Toilet Partition hinges) are for use on swinging single fire doors (max. door opening of 4'x10') or pairs of fire doors (max. door opening of 8' x10'), including double egress, installed in masonry or drywall. SELECT pin & barrel continuous hinges (excluding Toilet Partition hinges) are rated for 20 minutes on labeled wood doors, 1-1/2 hours for labeled hollow metal and composite-core wood fire doors, and 3 hours (NO FIRE PINS OR STUDS REQUIRED) for labeled hollow metal doors mounted singly only.





SWING CLEAR P&B CONTINUOUS HINGES

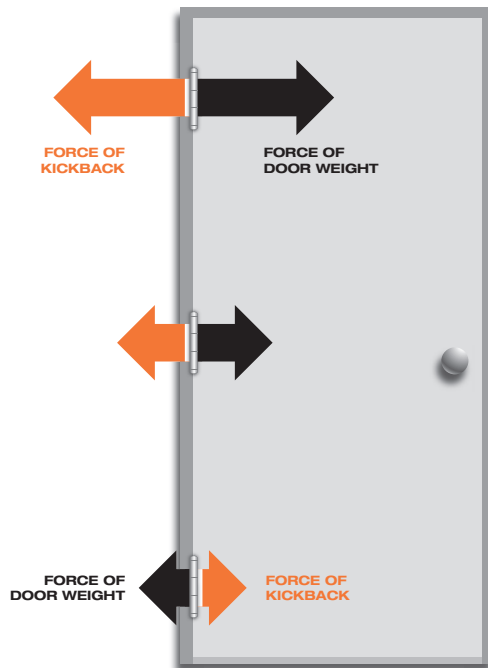


HINGE PART NUMBER INTERCHANGE: PIN & BARREL HINGES

SELECT MODELS	MARKAR	HAGER	PEMKO	MCKINNEY	STANLEY	ABH	IVES
SL310	HG-310			MCK HG310			
SL311	HG-311			MCK HG311	656	A511	711

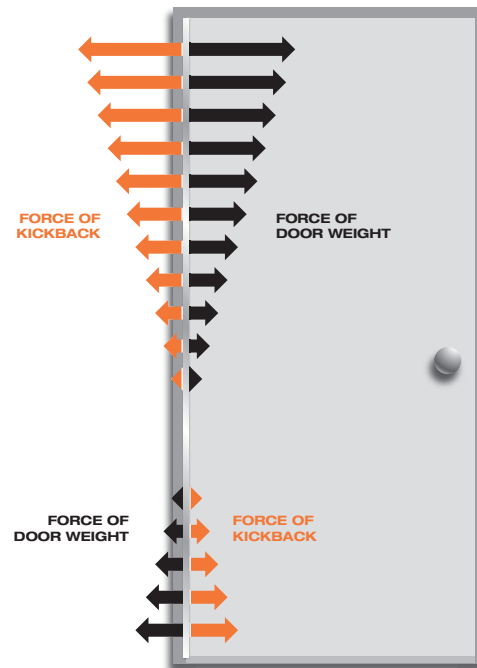
No equivalent hinge available from this manufacturer.

HINGE STRESS COMPARISON



CONVENTIONAL BUTT HINGES

On conventional hinges, opening and “kickback” energy from closers and automatic operators concentrates on the top butt hinge. This force works against the top hinge, eventually forcing it apart or pulling it from the frame/door.



CONTINUOUS HINGES

SELECT continuous hinges unite the door and frame into an integrated, sag-free unit. “Kickback” energy dissipates along the entire length of the door and frame and prevents hinge failure.

INSTALLATION INSTRUCTIONS

Swing Clear Pin & Barrel Continuous Hinge

SL310



PRODUCT MUST BE INSTALLED ACCORDING TO ALL APPLICABLE BUILDING AND LIFE SAFETY CODES

All holes in door and frame must be drilled correctly and fasteners properly installed. Failure to use fasteners supplied by Select Products Limited will void UL or WHI fire rated listing.

Important Warranty Information:

The following actions will void any warranty, expressed or implied:

- Failure to install the hinge according to the manufacturer's specifications and requirements. (for more information, visit selecthingerequirements.com)
- Use of fasteners other than those supplied with the hinge.
- Unauthorized field modifications, including alteration of the original finish or painting the hinge.

1. Frame Preparation

A. Place hinge frame leaf on frame face. Position top of hinge 1/8" maximum below header. Place hinge firmly against face of frame. Position frame leaf edge 3/16" from rabbet as shown in (Fig. 1 & 2).

B. Mark top and bottom two holes with hinge held firmly in place. Remove hinge. A center punch can help center hole so that fasteners will enter straight. Prepare to drill frame.

C. Drill Holes:

Wood Frame: Drill holes using a 5/32" drill bit.

Hollow Metal Frame: Drill holes using a #16 drill bit. If hollow metal frame is reinforced, thread all holes with #12-24 tap.

D. Install hinge with four screws:

Wood: Attach hinge using #12-8 x 1-1/2" Flat Head Undercut Wood Screws

Hollow Metal: Attach hinge using #12-24 x 11/16" Flat Head Undercut Self-Drilling Screws

E. Mark remaining mounting holes, remove hinge and repeat step C.

Do not install hinge to frame at this time.

2. Door Preparation

A. Place hinge door leaf on edge of door. Position top of hinge flush with top of door (Fig 3).

B. Mark and center punch each hole on door with hinge held firmly in place. Remove hinge from door and prepare to drill door.

C. Drilling Doors:

Non Adjustable Hinge

Wood Doors: Drill all holes using a 5/32" drill bit.

Hollow Metal Doors: Drill all holes using a #16 drill bit. If hollow metal door is reinforced, thread all holes with 12-24 tap.

Adjustable Hinge (If using Adjust-A-Screw™)

Wood Doors:

1. Drill all holes using a 5/32" drill bit then enlarge holes to 5/16" with a minimum depth of 13/8".
2. Insert Adjust-A-Screws into every hole.
3. Place a 7/32" Allen wrench in opening of Adjust-A-Screw and turn Adjust-A-Screw into hole while keeping screw properly aligned (Fig 4).
4. Drive all Adjust-A-Screws in until approximately 1/8" from edge of door. (*Adjust-A-Screw will self-tap*)

Hollow Metal Doors:

1. Drill all holes using a #16 drill bit then enlarge holes with a 5/16" drill bit.
2. Thread all holes with 3/8-16 tap.
3. Insert Adjust-A-Screws into every hole.
4. Place a 7/32" Allen wrench in opening of Adjust-A-Screw and turn Adjust-A-Screw into hole while keeping screw properly aligned (Fig 4).
5. Drive all Adjust-A-Screws in until approximately 1/8" from edge of door.

Note: It is not necessary to tap holes in wood doors since Adjust-A-Screws cut their own threads. Do not be concerned with a tight fit. Adjust-A-Screws are designed for a tight friction fit in tapped holes so they will not turn when attachment screw is being tightened. If Adjust-A-Screw turns too freely, apply Loctite™ to threads during installation.

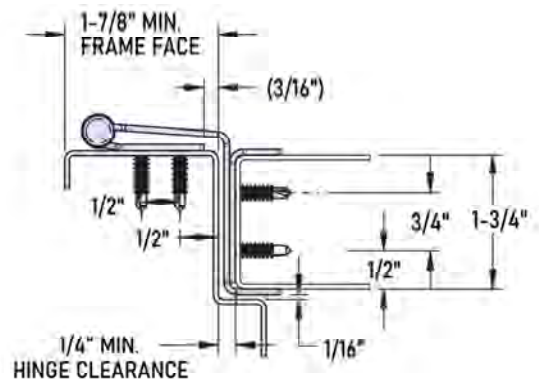
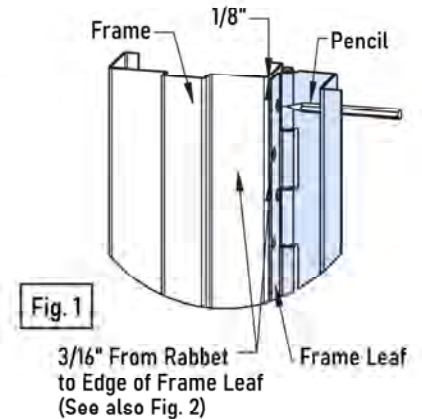


Fig. 2

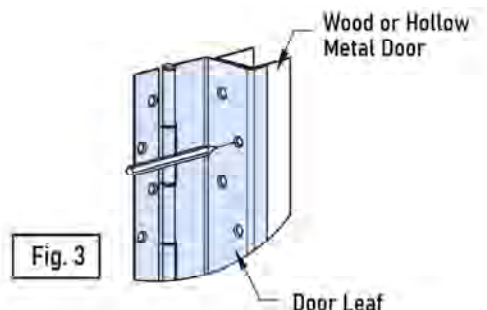


Fig. 3

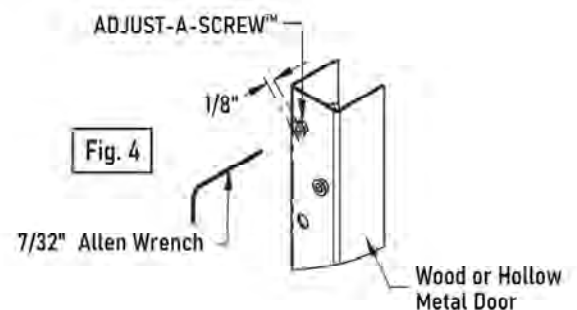


Fig. 4

3. Hinge Installation

A. Attaching hinge to door:

Peel backing from two sided tape located on top and bottom of hinge guard.
Stick guard to edge of door.

Non Adjustable Hinge (Fig 5)

Wood: Attach hinge using #12-8 x 1-1/2" Flat Head Undercut Wood Screws

Hollow Metal: Attach hinge using #12-24 x 11/16" Flat Head Undercut Self-Drilling Screws

Adjustable Hinge (Fig 6)

Wood & Hollow Metal: Attach hinge using #10-32 x 3/4" Flat Head Undercut Machine Screws

Install top & bottom four screws first, then close door to check alignment.
See Special Note below.

Special Note: If door is properly aligned, install and tighten remaining screws. If door requires alignment for proper fit, make this adjustment with four screws installed without removing door. Remove one screw and insert Allen wrench through hole into Adjust-A-Screw (Fig 6). Turn Adjust-A-Screw in direction desired for adjustment. One full turn of Allen wrench is equal to 1/16". Reinstall screw. Adjust remaining screws in same manner. Close door to verify door is aligned properly in opening. The balance of Adjust-A-Screw should be adjusted in same manner until all are resting firmly against inside face of hinge. Then install and tighten remaining machine screws. Be sure adjustable angle is pressed firmly against face of door as screws are tightened.

B. Attaching hinge to frame (Fig 7):

Wood: Attach hinge using #12-8 x 1-1/2" Flat Head Undercut Wood Screws

Hollow Metal: Attach hinge using #12-24 x 11/16" Flat Head Undercut Self-Drilling Screws

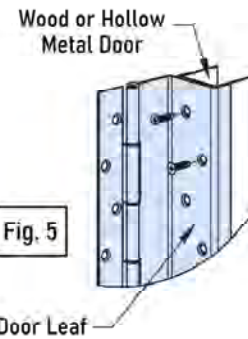


Fig. 5

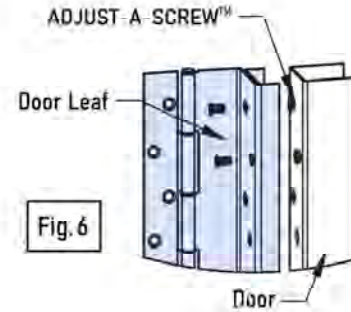


Fig. 6

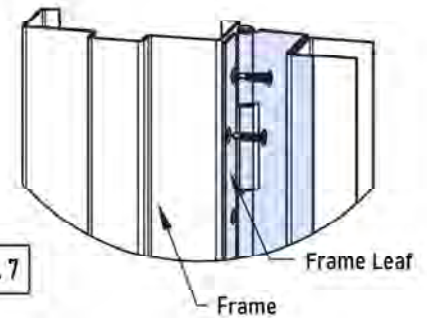
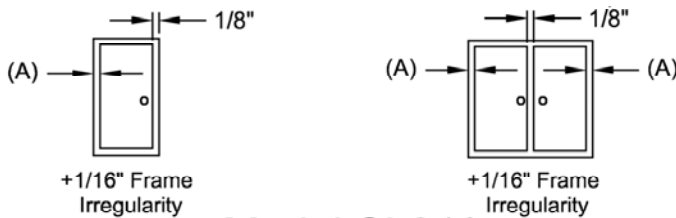


Fig. 7

Model SL310

Standard "Non-Adjustable" application clearances

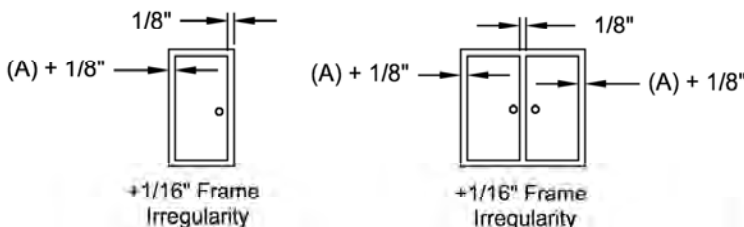
Clearance (A)	Total Under-Sizing Required	
	Single Door	Pair of Doors
1/4"	7/16"	11/16"



Model SL310

Standard "Adjustable" application clearances

Clearance (A)	Total Under-Sizing Required	
	Single Door	Pair of Doors
1/4"	9/16"	15/16"



NOTE: Proper door reinforcement is required for adjustable feature.

STANDARD HARDWARE	
	#12-24 X 11/16" FLAT HEAD UNDERCUT SELF-DRILLING SCREW (TKS1267SP10SS)
OPTIONAL HARDWARE AVAILABLE UPON REQUEST	
	#12-8 x 1-1/2" FLAT HEAD UNDERCUT WOOD SCREW (PBS12150SP10SS)
ADJUSTABILITY HARDWARE	
	#10-32 X 3/4" FLAT HEAD UNDERCUT MACHINE SCREW (MS10075SS)
	1-3/8" ADJUST-A-SCREW™ (M26-0031-01)
SECURITY SCREWPACKS M91-0031MM, M91-0031MW, M91-0031WW, M91-0002-630	



SELECT HINGES

SELECT Products Limited

3258 Stadium Park Way
Kalamazoo, MI 49009
PH: 800-423-1174
Fax: 800-423-7107
www.select-hinges.com

INSTALLATION INSTRUCTIONS

Swing Clear Pin & Barrel Continuous Hinge SL311



PRODUCT MUST BE INSTALLED ACCORDING TO ALL APPLICABLE BUILDING AND LIFE SAFETY CODES

All holes in door and frame must be drilled correctly and fasteners properly installed. Failure to use fasteners supplied by Select Products Limited will void UL or WHI fire rated listing.

Important Warranty Information:

The following actions will void any warranty, expressed or implied:

- Failure to install the hinge according to the manufacturer's specifications and requirements. (for more information, visit selecthingerequirements.com)
- Use of fasteners other than those supplied with the hinge.
- Unauthorized field modifications, including alteration of the original finish or painting the hinge.

1. Frame Preparation

A. Place hinge frame leaf on frame face. Position top of hinge $1/8"$ maximum below header. Place hinge firmly against face of frame. Position frame leaf edge $3/16"$ from rabbet as shown (Fig. 1 & 2).

B. Mark top and bottom two holes with hinge held firmly in place. Remove hinge. A center punch can help center hole so that fasteners will enter straight. Prepare to drill frame.

C. Drill Holes:

Wood Frame: Drill holes using a $5/32"$ drill bit.

Hollow Metal Frame: Drill holes using a #16 drill bit. If hollow metal frame is reinforced, thread all holes with #12-24 tap.

D. Install hinge with four screws:

Wood: Attach hinge using #12-8 x $1-1/2"$ Flat Head Undercut Wood Screws

Hollow Metal: Attach hinge using #12-24 x $11/16"$ Flat Head Undercut Self-Drilling Screws

E. Mark remaining mounting holes, remove hinge and repeat step C.

Do not install hinge to frame at this time.

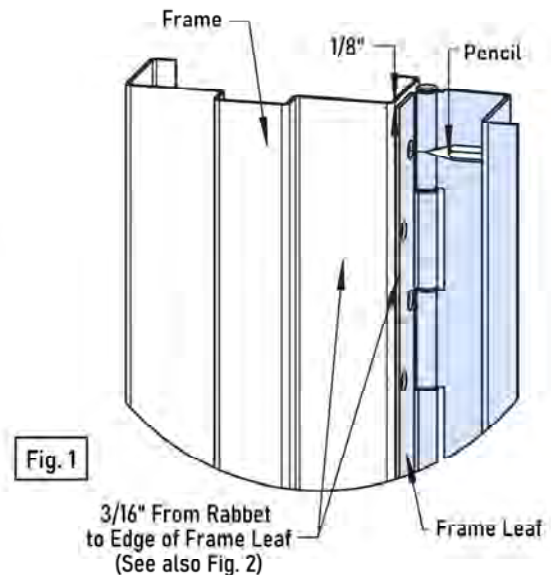


Fig. 1

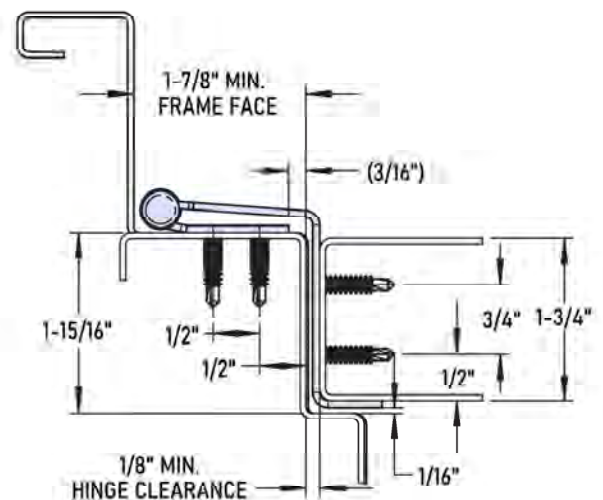


Fig. 2

2. Door Preparation

A. Place hinge door leaf on edge of door. Position top of hinge flush with top of door (Fig 3).

B. Mark and center punch each hole on door with hinge held firmly in place. Remove hinge from door and prepare to drill door.

C. Drilling Doors:

Wood Doors: Drill all holes using a 5/32" drill bit.

Hollow Metal Doors: Drill all holes using a #16 drill bit. If hollow metal door is reinforced, thread all holes with #12-24 tap.

3. Hinge Installation

A. Attaching hinge to door (Fig 4).

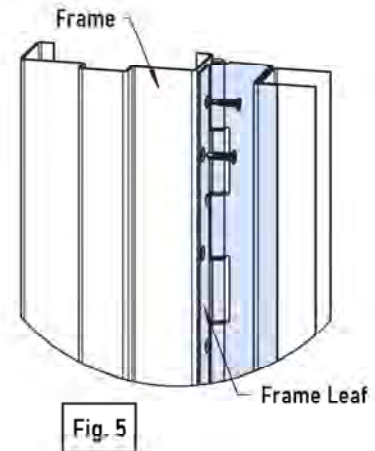
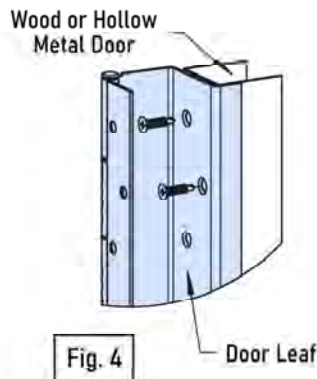
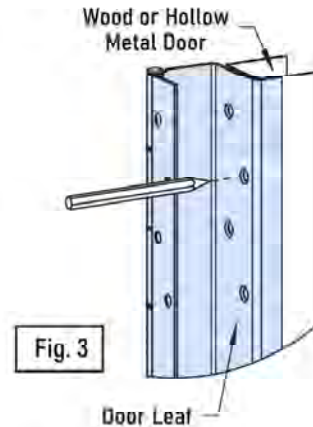
Wood: Attach hinge using #12-8 x 1-1/2" Flat Head Undercut Wood Screws

Hollow Metal: Attach hinge using #12-24 x 11/16" Flat Head Undercut Self-Drilling Screws

B. Attaching hinge to frame (Fig 5):

Wood: Attach hinge using #12-8 x 1-1/2" Flat Head Undercut Wood Screws

Hollow Metal: Attach hinge using #12-24 x 11/16" Flat Head Undercut Self-Drilling Screws

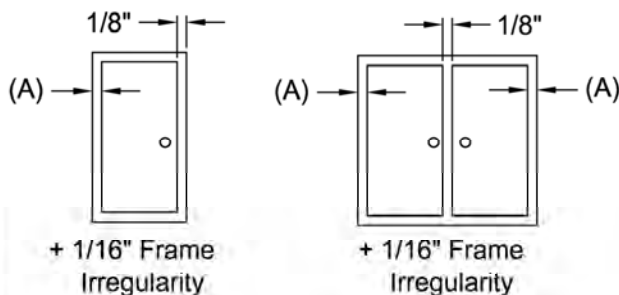




Model SL311

Standard "Non-Adjustable" application clearances

Total Under-Sizing Required

Clearance (A)	Single Door	Pair of Doors
1/8"	5/16"	7/16"



STANDARD HARDWARE
 #12-24 X 11/16" FLAT HEAD UNDERCUT SELF-DRILLING SCREW (TKS1267SP10SS)
OPTIONAL HARDWARE AVAILABLE UPON REQUEST
 #12-8 x 1-1/2" FLAT HEAD UNDERCUT WOOD SCREW (PBS12150SP10SS)
SECURITY SCREWPACKS M91-0031MM, M91-0031MW, M91-0031WW



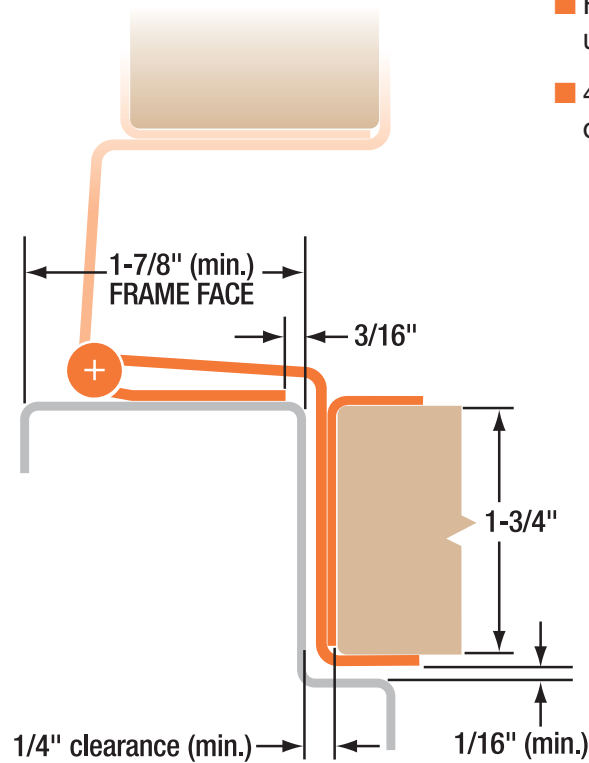
SELECT HINGES

SELECT Products Limited

3258 Stadium Park Way
 Kalamazoo, MI 49009
 PH: 800-423-1174
 Fax: 800-423-7107
 www.select-hinges.com



- Stainless steel
- Swing-clear action
- Door guard
- Universal Adjusta-Screw™ fasteners (right-hand thread) available at extra cost
- For 1-3/4" doors weighing up to 600 lb.
- 48" maximum door width



SL310
Swing Clear Pin & Barrel Continuous Hinge

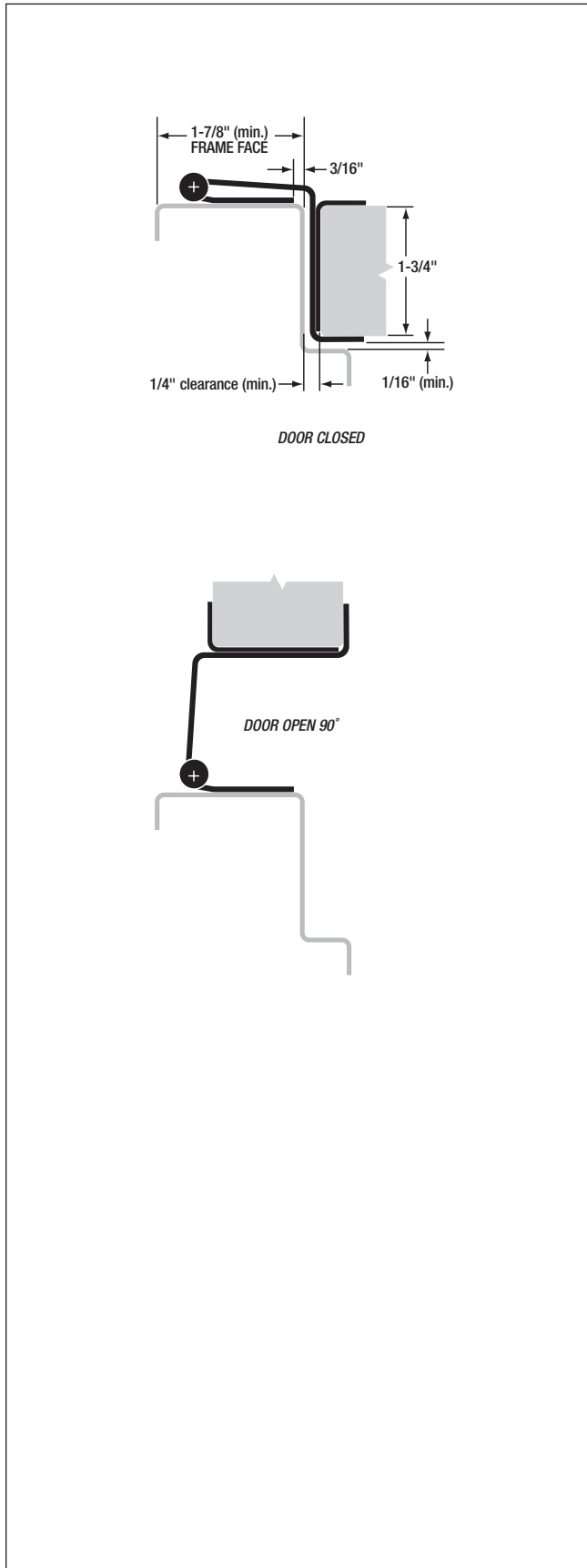


SL310

NOTES:

Lined area for notes, consisting of multiple horizontal lines.

SL310 Swing Clear Pin & Barrel Hinge



MATERIAL: 14 gauge 304 stainless steel barrel with 3/16" diameter 304 stainless pin. Long-life nylon medical bearings.

LENGTHS: 79", 83", 85", 95" and 119" lengths standard for nominal door heights. Custom lengths are available.

LOAD/FREQUENCY: For 1-3/4" doors, 48" wide (max.), weighing up to 400 pounds (medium-frequency) without frame or door reinforcement; up to 600 pounds (low-frequency) without frame or door reinforcement.

FINISH: US32D satin stainless steel (630).

CLOSERS: Conventional overhead surface, concealed sliding arm overhead or floor closers may be used with SELECT hinges. Pivot-type floor closers (with a fixed, conflicting center pivot) must be replaced.

ORDER: Specify hinge length. Screw pack contains 12-24 x 7/8" 410SS Phillips flathead undercut self-drilling Tek® screws and 10 x 1-1/4" 410SS Phillips flathead undercut sheet metal screws. Adjusta-Screw™ fasteners available at extra cost.



SL310 HINGE SCREW COUNT		
HINGE LENGTH	DOOR SCREWS	FRAME SCREWS
79"	18	18
83"	21	21
85"	18	18
95"	23	23
119"	27	27

SPECIFICATIONS

SL310 Swing Clear Pin & Barrel Hinge



SELECT ADVANTAGES



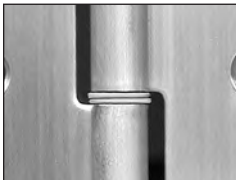
CORROSION-RESISTANT STAINLESS STEEL

Stainless steel pin & barrel design creates a tough, highly secure opening.



TEMPLATED HOLE PATTERN

SELECT hinges line up perfectly, precisely, every time. Makes installation easier and faster.



DUST-FREE (MEDICAL) BEARINGS

Prevent metal-to-metal contact and eliminate dust. Exclusive standard (no upcharge) on all SELECT Pin & Barrel hinges.



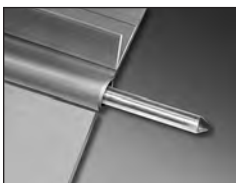
VARIETY OF FINISHES

Available in polished, brushed and painted finishes to match, contrast or accent your building's design.



3-HR. FIRE RATING

Fire-rated out of the package. No extra parts to buy or install. No liability worries.



STAINLESS STEEL PIN

Delivers high tensile strength by forming a strong, free-moving unit. Flexible and strong in abused openings.



END CAPS

Spiral-knurled steel caps seal the barrel ends to contain hinge pin.



ADJUSTA-SCREW™ FASTENERS

Remedy out-of-square doors and frames easily. Correct fit variances up to 3/8" along full length of door. Available at extra cost.

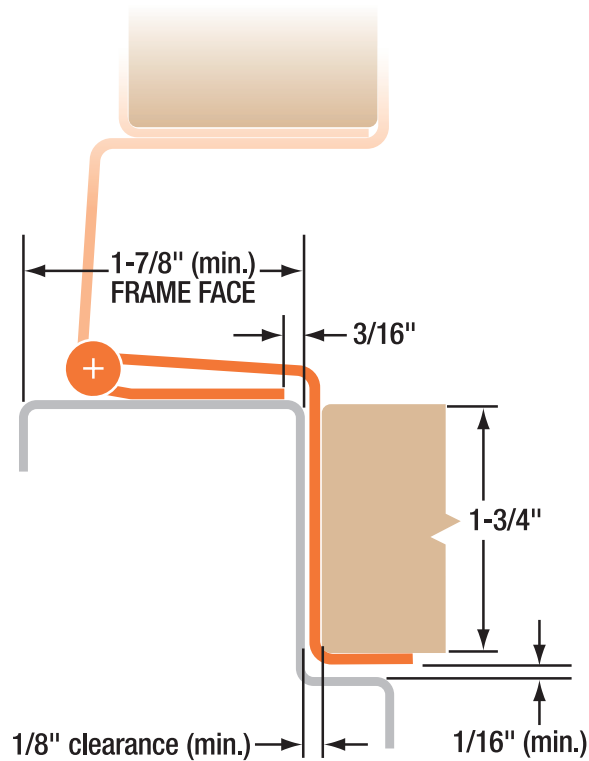
SELECT HINGE PERFORMANCE

- SELECT pin & barrel continuous hinges are built to handle abuse from high-traffic applications. They are applied to the surface on the edge of the frame and door. No machining or reinforcement is required.
- On conventional hinges, opening and “kick-back” energy concentrate on a few inches of fastened reinforcing plate — with the top hinge handling 100% of the force. Pinless SELECT hinges bond the door and frame into an integrated, sag-free unit. “Kick-back” energy dissipates along the entire length of the door and frame. (Compare this to a conventional hinge’s 4-1/2" to 5" at the top of the door and frame).
- SELECT pin & barrel continuous hinges eliminate the gap between the door and frame, providing a weatherproof, rust-proof, tamper-proof barrier.
- SELECT pin & barrel continuous hinges (excluding Toilet Partition hinges) are listed and tested by Underwriters Laboratories to meet the Positive pressure requirements of UL10C, and are in accordance with UBC 7.2 (1997). SELECT pin & barrel continuous hinges (excluding Toilet Partition hinges) are for use on swinging single fire doors (max. door opening of 4'x10') or pairs of fire doors (max. door opening of 8' x10'), including double egress, installed in masonry or drywall. SELECT pin & barrel continuous hinges (excluding Toilet Partition hinges) are rated for 20 minutes on labeled wood doors, 1-1/2 hours for labeled hollow metal and composite-core wood fire doors, and 3 hours (NO FIRE PINS OR STUDS REQUIRED) for labeled hollow metal doors mounted singly only.





- Stainless steel
- Swing-clear action
- Edge guard
- For 1-3/4" doors weighing up to 600 lb.
- 48" maximum door width



SL311
Swing Clear Pin & Barrel Continuous Hinge

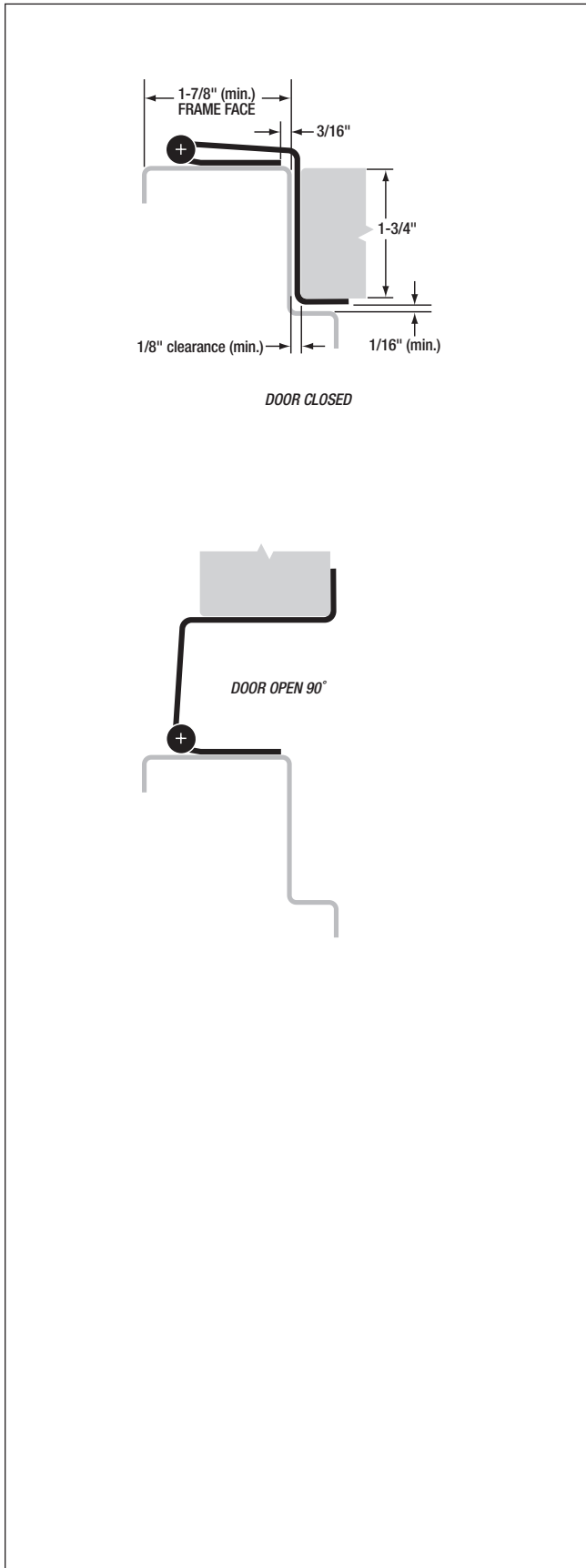


SL311

NOTES:

Lined area for notes, consisting of 25 horizontal orange lines.

SL311 Swing Clear Pin & Barrel Hinge



MATERIAL: 14 gauge 304 stainless steel barrel with 3/16" diameter 304 stainless pin. Long-life nylon medical bearings.

LENGTHS: 79", 83", 85", 95" and 119" lengths standard for nominal door heights. Custom lengths are available.

LOAD/FREQUENCY: For 1-3/4" doors, 48" wide (max.), weighing up to 400 lb. (medium-frequency) without frame or door reinforcement; up to 600 lb. (low-frequency) without frame or door reinforcement.

FINISH: US32D satin stainless steel (630).

CLOSERS: Conventional overhead surface, concealed sliding arm overhead or floor closers may be used with SELECT hinges. Pivot-type floor closers (with a fixed, conflicting center pivot) must be replaced.

ORDER: Specify hinge length. Screw pack contains 12-24 x 7/8" 410SS Phillips flathead undercut self-drilling Tek® screws and 10 x 1-1/4" 410SS Phillips flathead undercut sheet metal screws.



SL311 HINGE SCREW COUNT		
HINGE LENGTH	DOOR SCREWS	FRAME SCREWS
79"	18	18
83"	21	21
85"	18	18
95"	23	23
119"	27	27

SPECIFICATIONS

SL311 Swing Clear Pin & Barrel Hinge



SELECT ADVANTAGES



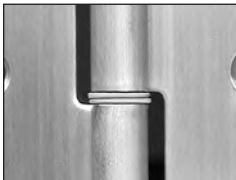
CORROSION-RESISTANT STAINLESS STEEL

Stainless steel pin & barrel design creates a tough, highly secure opening.



TEMPLATED HOLE PATTERN

SELECT hinges line up perfectly, precisely, every time. Makes installation easier and faster.



DUST-FREE (MEDICAL) BEARINGS

Prevent metal-to-metal contact and eliminate dust. Exclusive standard (no upcharge) on all SELECT Pin & Barrel hinges.



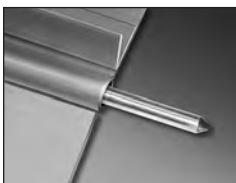
VARIETY OF FINISHES

Available in polished, brushed and painted finishes to match, contrast or accent your building's design.



3-HR. FIRE RATING

Fire-rated out of the package. No extra parts to buy or install. No liability worries.



STAINLESS STEEL PIN

Delivers high tensile strength by forming a strong, free-moving unit. Flexible and strong in abused openings.



END CAPS

Spiral-knurled steel caps seal the barrel ends to contain hinge pin.

SELECT HINGE PERFORMANCE

- SELECT pin & barrel continuous hinges are built to handle abuse from high-traffic applications. They are applied to the surface on the edge of the frame and door. No machining or reinforcement is required.
- On conventional hinges, opening and “kick-back” energy concentrate on a few inches of fastened reinforcing plate — with the top hinge handling 100% of the force. Pinless SELECT hinges bond the door and frame into an integrated, sag-free unit. “Kick-back” energy dissipates along the entire length of the door and frame. (Compare this to a conventional hinge’s 4-1/2" to 5" at the top of the door and frame).
- SELECT pin & barrel continuous hinges eliminate the gap between the door and frame, providing a weatherproof, rust-proof, tamper-proof barrier.
- SELECT pin & barrel continuous hinges (excluding Toilet Partition hinges) are listed and tested by Underwriters Laboratories to meet the Positive pressure requirements of UL10C, and are in accordance with UBC 7.2 (1997). SELECT pin & barrel continuous hinges (excluding Toilet Partition hinges) are for use on swinging single fire doors (max. door opening of 4'x10') or pairs of fire doors (max. door opening of 8' x10'), including double egress, installed in masonry or drywall. SELECT pin & barrel continuous hinges (excluding Toilet Partition hinges) are rated for 20 minutes on labeled wood doors, 1-1/2 hours for labeled hollow metal and composite-core wood fire doors, and 3 hours (NO FIRE PINS OR STUDS REQUIRED) for labeled hollow metal doors mounted singly only.

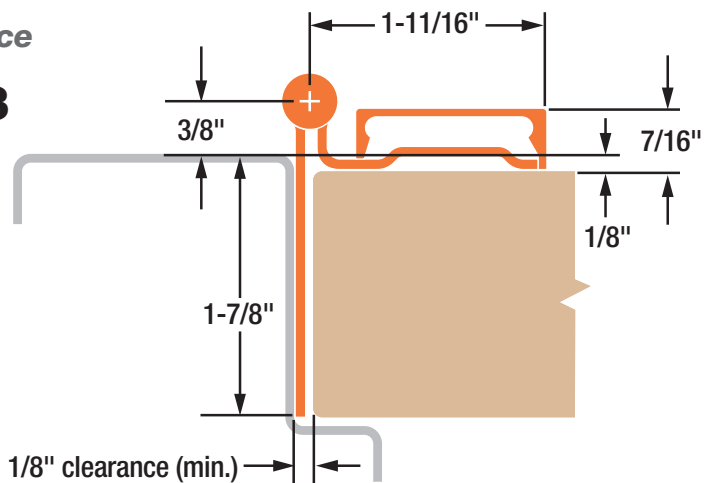




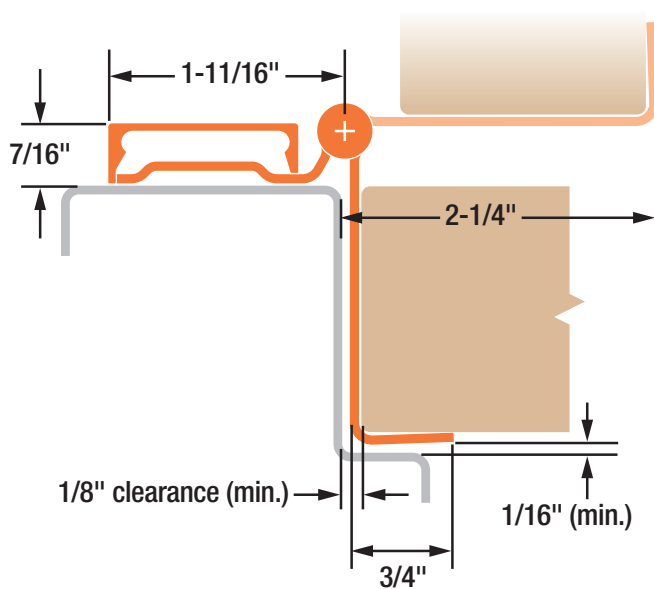
**SELECT
HINGES™**

HALF SURFACE • HALF MORTISE P&B HINGES

Half Surface
SL303



Half Mortise
SL306



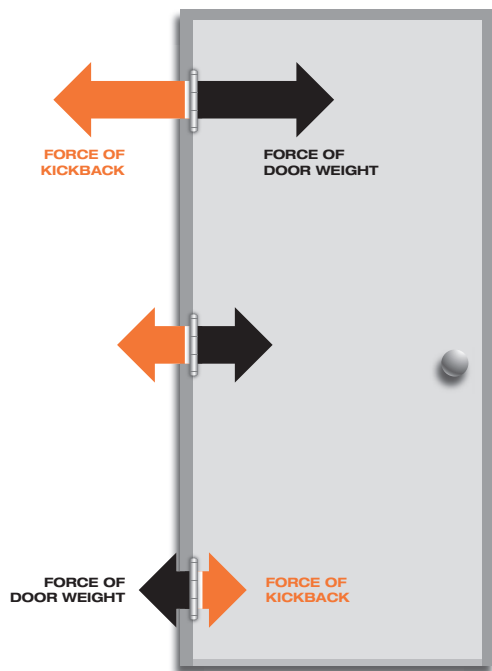
HALF SURFACE • HALF MORTISE

HINGE PART NUMBER INTERCHANGE: PIN & BARREL HINGES

SELECT MODELS	MARKAR	HAGER	PEMKO	MCKINNEY	STANLEY	ABH	IVES
SL303	HS-303	790-903	SPBHS	MCK HS303		A503	
SL306	HG-306	790-906		MCK HG306	655	A506	

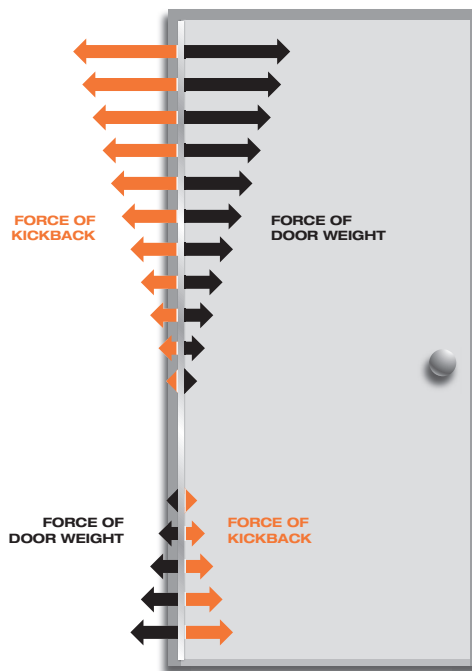
No equivalent hinge available from this manufacturer.

HINGE STRESS COMPARISON



CONVENTIONAL BUTT HINGES

On conventional hinges, opening and “kickback” energy from closers and automatic operators concentrates on the top butt hinge. This force works against the top hinge, eventually forcing it apart or pulling it from the frame/door.



CONTINUOUS HINGES

SELECT continuous hinges unite the door and frame into an integrated, sag-free unit. “Kickback” energy dissipates along the entire length of the door and frame and prevents hinge failure.

INSTALLATION INSTRUCTIONS

Half Surface Pin and Barrel Continuous Hinge

SL303



PRODUCT MUST BE INSTALLED ACCORDING TO ALL APPLICABLE BUILDING AND LIFE SAFETY CODES

All holes in door and frame must be drilled correctly and fasteners properly installed. Failure to use fasteners supplied by Select Products Limited will void UL or WHI fire rated listing.

Important Warranty Information:

The following actions will void any warranty, expressed or implied:

- Failure to install the hinge according to the manufacturer's specifications and requirements. (for more information, visit selecthingerequirements.com)
- Use of fasteners other than those supplied with the hinge.
- Unauthorized field modifications, including alteration of the original finish or painting the hinge.

Do Not install Snap-On Cover until installation is 100% complete, and all aspects of the assembly are correctly fastened and properly fitted. The cover is impossible to remove without damage and replacement may be necessary.

Perform each step of the following instructions:

1. Frame Preparation and Mounting

- A. Place hinge on frame. Position top of hinge $1/8"$ maximum below. Allow $1/16"$ between stop and edge of hinge (Fig. 1).
- B. Mark the position of the top and bottom holes with a center punch, then drill and fasten with the #12-24 x $11/16"$ Flat Head Undercut Self-Drilling Screws. The use of the center punch can help center the hole so that the fasteners will enter straight.
- C. After the top and bottom screws are installed, drill and fasten the balance of the holes.

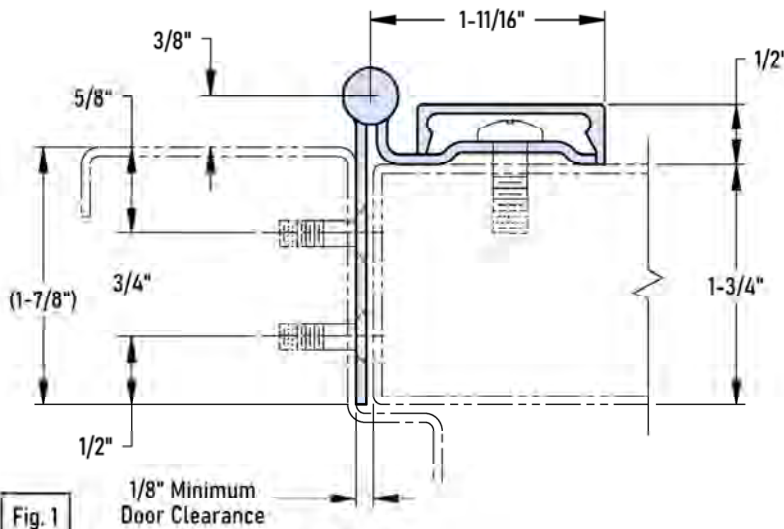







Fig. 1

$1/8"$ Minimum Door Clearance

STANDARD HARDWARE	
	$1/4$ -20 X $3/4$ " TORX PAN HEAD SELF-DRILLING SCREW (TKS14075R)
	#12-24 X $11/16$ " FLAT HEAD UNDERCUT SELF-DRILLING SCREW (TKS1267SP10SS)
	#8 X $3/4$ " FLAT HEAD UNDERCUT SELF-DRILLING SCREW (TKS8075Z)
	COVER CLIP (606 M22-0130-01)
OPTIONAL HARDWARE AVAILABLE UPON REQUEST	
	#12-8 X $1-1/2$ " FLAT HEAD UNDERCUT WOOD SCREW (PBS12150SP10SS)
SCREWPACK KMSSS AND SECURITY SCREWPACKS M91-0031MM, M91-0031WW, M91-0063-630	

2. Door Preparation and Mounting

- A. Fold the door leaf back over the frame leaf and place the door in the door frame.
- B. Place shims under the door to provide 1/8" clearance between the header and top of the door.
- C. Add shims at both the hinge and latch side of the door so that 1/8" clearance will be maintained on the lock side of the door.
- D. With the door held firmly in place, return the door leaf to the face of the door and repeat the drilling procedure described in steps (1B) and (1C) above, but using the 1/4"-20 x 3/4" Torx Pan Head Self-Drilling Screws.
- E. Install the Snap-On covers by engaging the side of the cover next to the hinge pin first.
- F. Insert a large screwdriver between the hinge knuckle and the cover. Using the screwdriver as a lever, twist it and snap the opposite side of the cover onto the clip.
- G. Start at the top and work downward until the entire length of each cover is firmly engaged.
- H. With the covers firmly in place, secure them at both ends through the hinge and into the door and frame with #8 x 3/4" Flat Head Undercut Self-Drilling Screws.

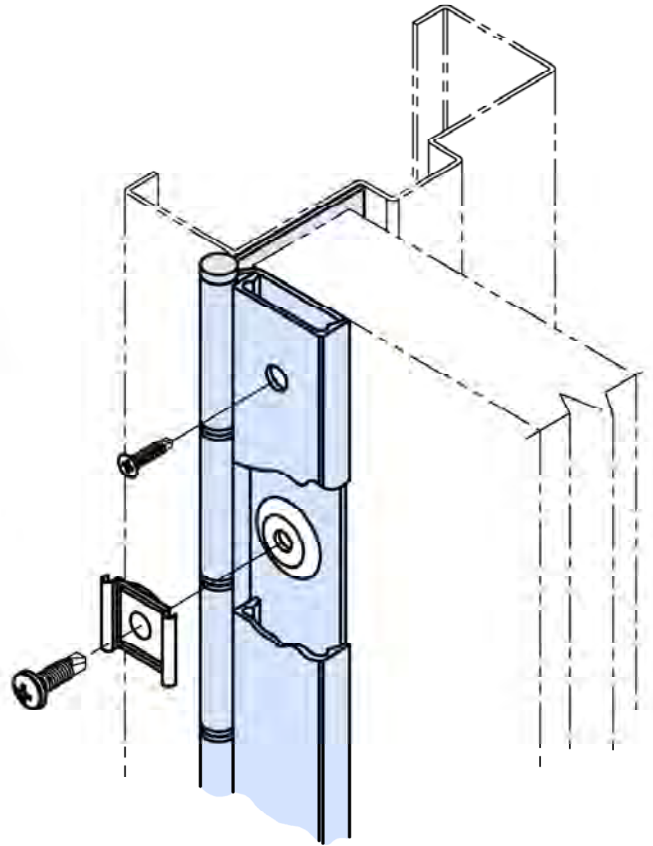


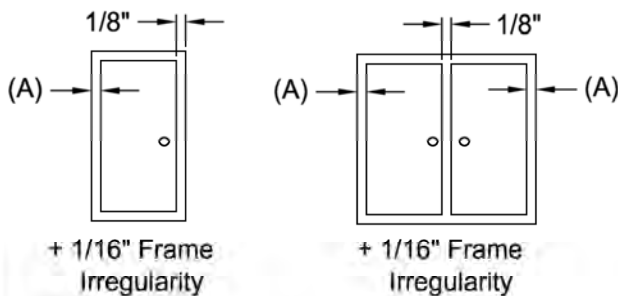
Fig. 2

Model SL303

Standard "Non-Adjustable" application clearances

Total Under-Sizing Required

Clearance (A)	Single Door	Pair of Doors
1/8"	5/16"	7/16"



**SELECT
HINGES®**

SELECT Products Limited

3258 Stadium Park Way
Kalamazoo, MI 49009
PH: 800-423-1174
Fax: 800-423-7107
www.select-hinges.com

A-03-17-08-20

INSTALLATION INSTRUCTIONS

Half Mortise Pin and Barrel Continuous Hinge

SL306



PRODUCT MUST BE INSTALLED ACCORDING TO ALL APPLICABLE BUILDING AND LIFE SAFETY CODES

All holes in door and frame must be drilled correctly and fasteners properly installed. Failure to use fasteners supplied by Select Products Limited will void UL or WHI fire rated listing.

Important Warranty Information:

The following actions will void any warranty, expressed or implied:

- Failure to install the hinge according to the manufacturer's specifications and requirements. (for more information, visit selecthingerequirements.com)
- Use of fasteners other than those supplied with the hinge.
- Unauthorized field modifications, including alteration of the original finish or painting the hinge.

Do Not install Snap-On Cover until installation is 100% complete, and all aspects of the assembly are correctly fastened and properly fitted. The cover is impossible to remove without damage and replacement may be necessary.

Perform each step of the following instructions:

1. Door Preparation and Mounting

- Place the hinge on the door as shown (Fig. 1). Carefully line up the hinge with the top and back edges of the door.
- Mark all hole locations on the door with the hinge held firmly in place.
- Center punch each hole. The use of the center punch can help center the hole so that the fasteners will enter straight.
- Attach the hinge to the door using the 1/4-20 x 3/4" Torx Pan Head Self-Drilling Screws.

2. Frame Preparation and Mounting

- Place the door into the frame. Place shims under the door to provide 1/8" clearance between the header and the top of the door. Add shims at both the hinge and latch side of the door so that 1/8" clearance will be maintained.

Note: 1-5/8" min of frame face is required for mounting this hinge.

- Fold the frame leaf over the face of the frame, mark the position of the top and bottom holes with a center punch, then drill and fasten with the #12-24 x 11/16" Flat Head Undercut Self-Drilling Screws.
- After the top and bottom screws are installed, drill and fasten the balance of the holes.
- Install at least five cover clips by passing a screw through the clip, hinge leaf and frame (Fig. 2).

It is recommended that clips be positioned in the top, center and bottom holes, with the remaining clips spaced equally along the length of the hinge

- Close the door and check for proper fit, make this adjustment by loosening screws on the door leaf and shimming where needed.

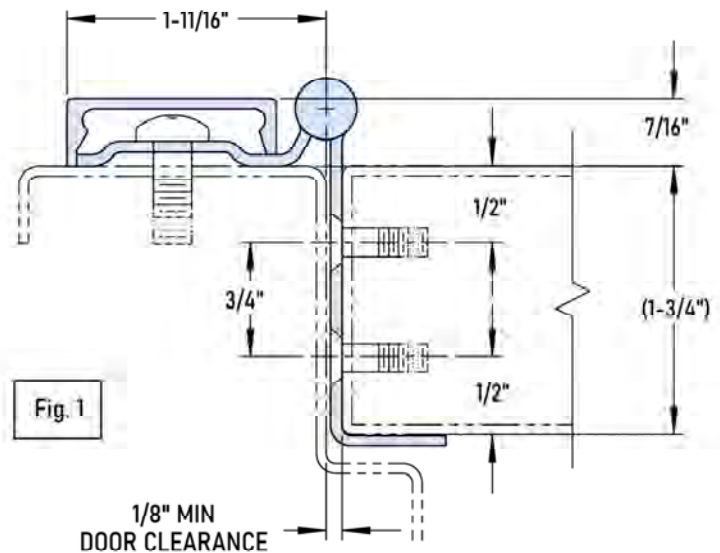
- When installation is complete, install the Snap-On cover.

- Engage the side of the cover next to the hinge pin first.

- Insert a large screwdriver between the hinge knuckle and the cover. Using the screwdriver as a lever, twist it and snap the opposite side of the cover onto the clip.

- Start at the top and work downward until the entire length of the cover is engaged.

- With the covers firmly in place, secure them at both ends through the hinge and into the door and frame with #8 x 3/4" Flat Head Undercut Self-Drilling Screws.



1/8" MIN
DOOR CLEARANCE

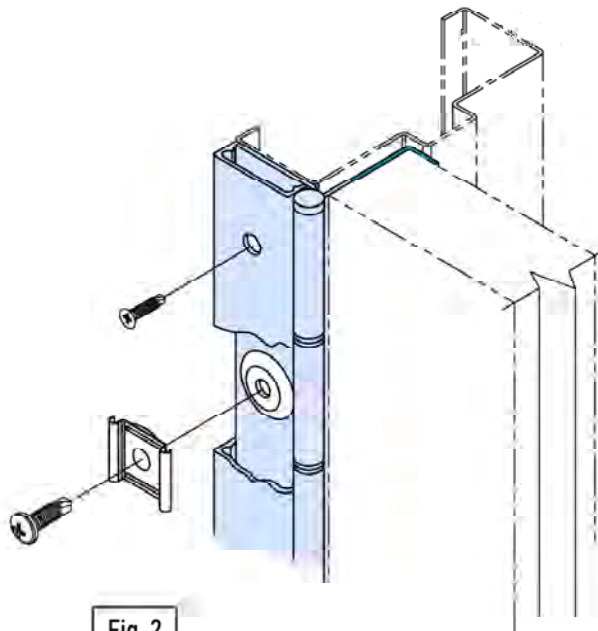


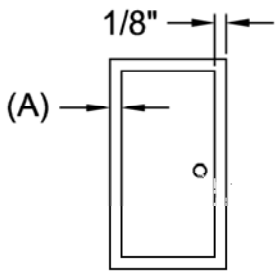
Fig. 2

Model SL306

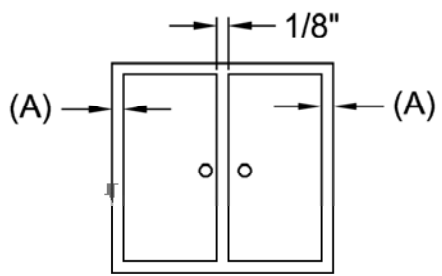
Standard "Non-Adjustable" application clearances

Total Under-Sizing Required

Clearance (A)	Single Door	Pair of Doors
1/8"	5/16"	7/16"



+ 1/16" Frame Irregularity



+ 1/16" Frame Irregularity

STANDARD HARDWARE	
1/4-20 X 3/4" TORX PAN HEAD SELF-DRILLING SCREW (TKS14075R)	
#12-24 X 11/16" FLAT HEAD UNDERCUT SELF-DRILLING SCREW (TKS1267SPI0SS)	
#8 X 3/4" FLAT HEAD UNDERCUT SELF-DRILLING SCREW (TKS8075Z)	
COVER CLIP (606 M22-0130-01)	
OPTIONAL HARDWARE AVAILABLE UPON REQUEST	
#12-8 x 1-1/2" FLAT HEAD UNDERCUT WOOD SCREW (PBS12150SPI0SS)	
SCREWPACK KMSSS AND SECURITY SCREWPACKS M91-0031MM, M91-0031WW, M91-0063-630	

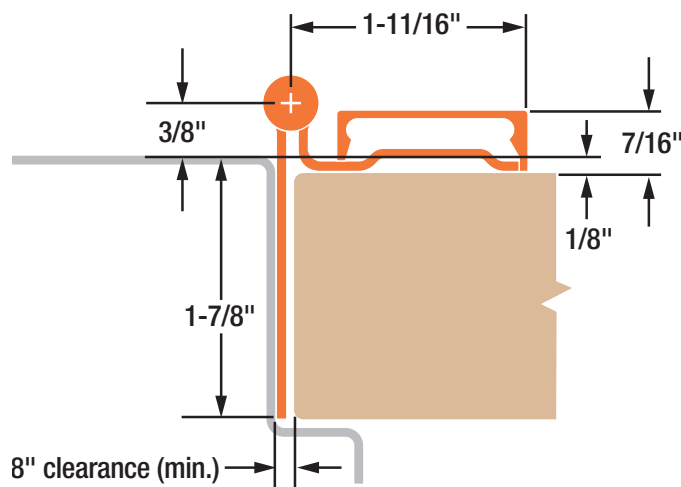


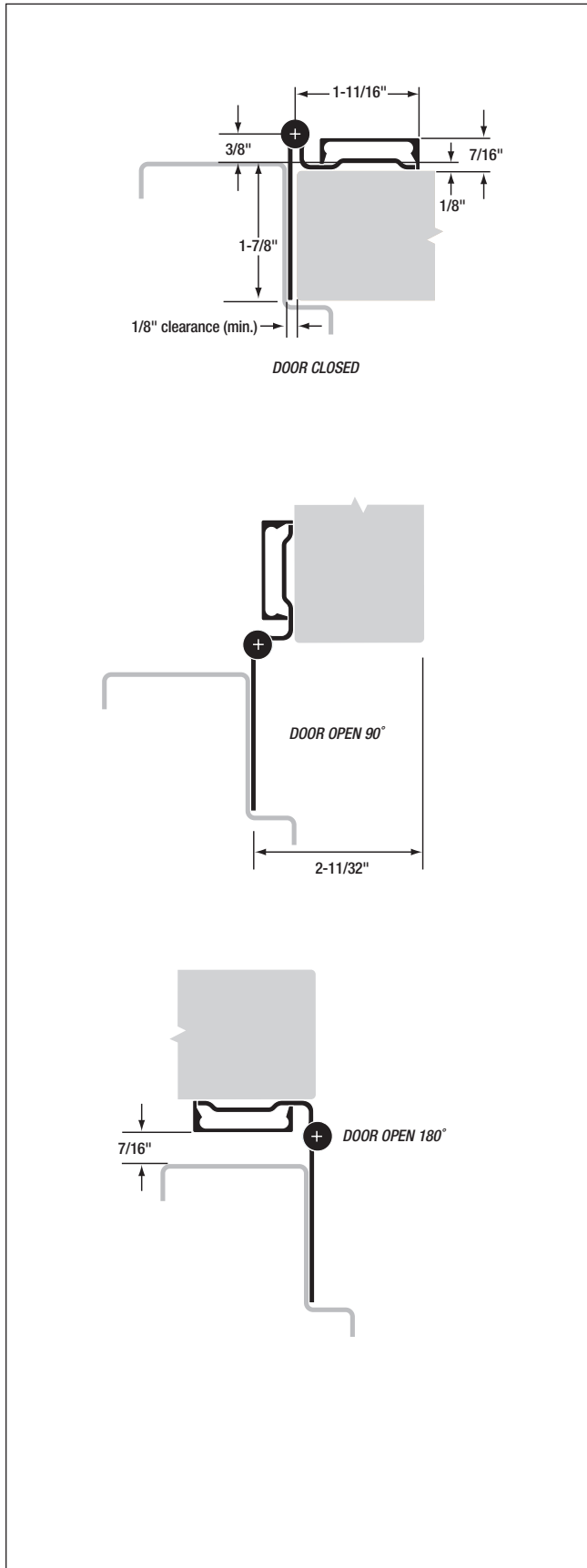
SELECT HINGES
SELECT Products Limited

3258 Stadium Park Way
Kalamazoo, MI 49009
PH: 800-423-1174
Fax: 800-423-7107
www.select-hinges.com



- Stainless steel
- Mounts on door face and frame rabbet
- Tamper-resistant door leaf cover
- 1/8" door inset
- For 1-3/4" doors weighing up to 600 lb.
- 48" maximum door width



SL303 Half Surface Pin & Barrel Hinge


MATERIAL: 14 gauge 304 stainless steel barrel with 3/16" diameter 304 stainless pin. Long-life nylon medical bearings.

LENGTHS: 79", 83", 85", 95" and 119" lengths standard for nominal door heights. Custom lengths are available.

LOAD/FREQUENCY: For 1-3/4" doors, 48" wide (max.), weighing up to 400 lb. (medium-frequency) without frame or door reinforcement; up to 600 lb. (low-frequency) without frame or door reinforcement.

FINISH: US32D satin stainless steel (630).

CLOSERS: Conventional overhead surface, concealed sliding arm overhead or floor closers may be used with SELECT hinges. Pivot-type floor closers (with a fixed, conflicting center pivot) must be replaced.

ORDER: Specify hinge length. Screw pack contains 10-24 x 7/8" 410SS Phillips flathead undercut self-drilling Tek® screws, 10 x 1-1/4" 410SS Phillips flathead undercut sheet metal screws, 1/4-20 x 3/4" zinc plated Torx® panhead self-drilling Tek® screws, 8 x 3/4" zinc plated Phillips flathead undercut self-drilling Tek® screws and zinc plated cover clips.

AVAILABLE ELECTRIC PREPS: CTP-AR and CTP-VD.



SL303 HINGE SCREW COUNT		
HINGE LENGTH	DOOR SCREWS	FRAME SCREWS
79"	13	18
83"	14	21
85"	14	18
95"	16	23
119"	20	27

SPECIFICATIONS

SL303 Half Surface Pin & Barrel Hinge



SELECT ADVANTAGES



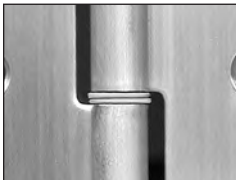
CORROSION-RESISTANT STAINLESS STEEL

Stainless steel pin & barrel design creates a tough, highly secure opening.



TEMPLATED HOLE PATTERN

SELECT hinges line up perfectly, precisely, every time. Makes installation easier and faster.



DUST-FREE (MEDICAL) BEARINGS

Prevent metal-to-metal contact and eliminate dust. Exclusive standard (no upcharge) on all SELECT Pin & Barrel hinges.



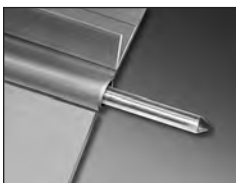
VARIETY OF FINISHES

Available in polished, brushed and painted finishes to match, contrast or accent your building's design.



3-HR. FIRE RATING

Fire-rated out of the package. No extra parts to buy or install. No liability worries.



STAINLESS STEEL PIN

Delivers high tensile strength by forming a strong, free-moving unit. Flexible and strong in abused openings.



END CAPS

Spiral-knurled steel caps seal the barrel ends to contain hinge pin.

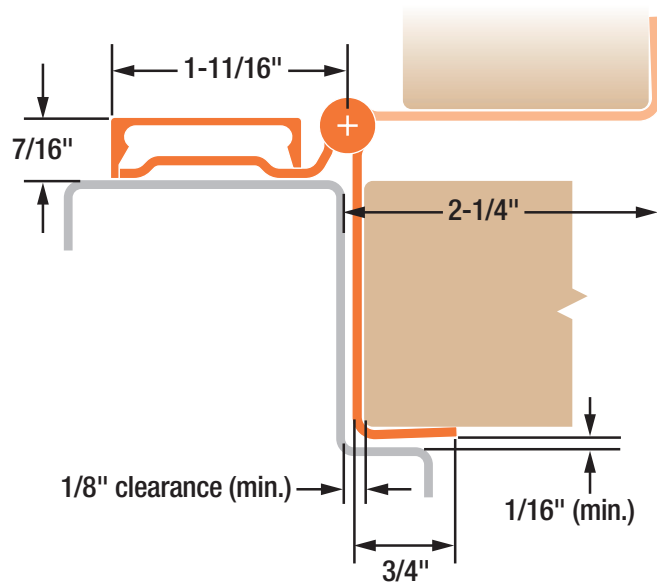
SELECT HINGE PERFORMANCE

- SELECT pin & barrel continuous hinges are built to handle abuse from high-traffic applications. They are applied to the surface on the edge of the frame and door. No machining or reinforcement is required.
- On conventional hinges, opening and “kick-back” energy concentrate on a few inches of fastened reinforcing plate — with the top hinge handling 100% of the force. Pinless SELECT hinges bond the door and frame into an integrated, sag-free unit. “Kick-back” energy dissipates along the entire length of the door and frame. (Compare this to a conventional hinge’s 4-1/2" to 5" at the top of the door and frame).
- SELECT pin & barrel continuous hinges eliminate the gap between the door and frame, providing a weatherproof, rust-proof, tamper-proof barrier.
- SELECT pin & barrel continuous hinges (excluding Toilet Partition hinges) are listed and tested by Underwriters Laboratories to meet the Positive pressure requirements of UL10C, and are in accordance with UBC 7.2 (1997). SELECT pin & barrel continuous hinges (excluding Toilet Partition hinges) are for use on swinging single fire doors (max. door opening of 4'x10') or pairs of fire doors (max. door opening of 8' x10'), including double egress, installed in masonry or drywall. SELECT pin & barrel continuous hinges (excluding Toilet Partition hinges) are rated for 20 minutes on labeled wood doors, 1-1/2 hours for labeled hollow metal and composite-core wood fire doors, and 3 hours (NO FIRE PINS OR STUDS REQUIRED) for labeled hollow metal doors mounted singly only.

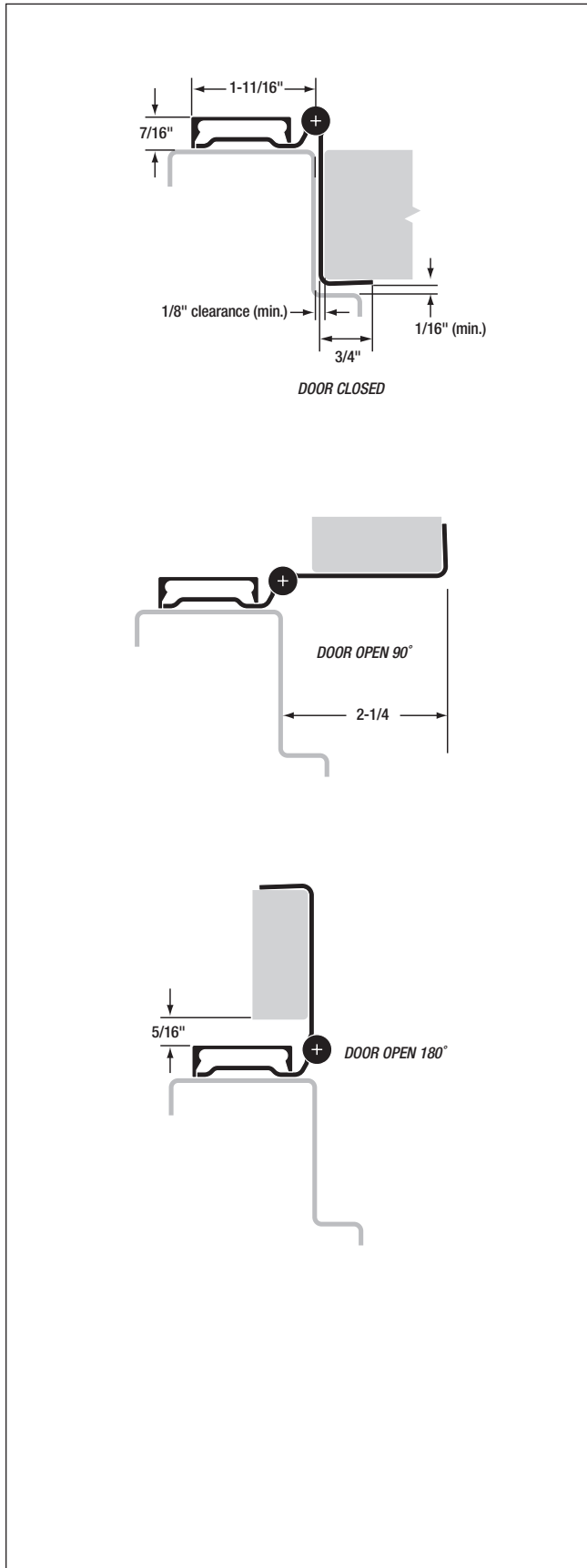




- Stainless steel
- Mounts on frame face and door edge
- Tamper-resistant frame leaf cover
- Edge guard
- For 1-3/4" doors weighing up to 600 lb.
- 48" maximum door width



SL306 Half Mortise Pin & Barrel Hinge



MATERIAL: 14 gauge 304 stainless steel barrel with 3/16" diameter 304 stainless pin. Long-life nylon medical bearings.

LENGTHS: 79", 83", 85", 95" and 119" lengths standard for nominal door heights. Custom lengths are available.

LOAD/FREQUENCY: For 1-3/4" doors, 48" wide (max.), weighing up to 400 lb. (medium-frequency) without frame or door reinforcement; up to 600 lb. (low-frequency) without frame or door reinforcement.

FINISH: US32D satin stainless steel (630).

CLOSERS: Conventional overhead surface, concealed sliding arm overhead or floor closers may be used with SELECT hinges. Pivot-type floor closers (with a fixed, conflicting center pivot) must be replaced.

ORDER: Specify hinge length. Screw pack contains 12-24 x 7/8" 410SS Phillips flathead undercut self-drilling Tek® screws, 10 x 1-1/4" 410SS Phillips flathead undercut sheet metal screws, 1/4-20 x 3/4" zinc plated Torx® panhead self-drilling Tek® screws, 8 x 3/4" zinc plated Phillips flathead undercut self-drilling Tek® screws and zinc plated cover clips.

AVAILABLE ELECTRIC PREPS: CTP-AR and CTP-VD.



SL306 HINGE SCREW COUNT		
HINGE LENGTH	DOOR SCREWS	FRAME SCREWS
79"	18	13
83"	21	14
85"	18	14
95"	23	16
119"	27	20

SELECT ADVANTAGES



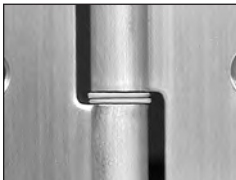
**CORROSION-RESISTANT
STAINLESS STEEL**

Stainless steel pin & barrel design creates a tough, highly secure opening.



TEMPLATED HOLE PATTERN

SELECT hinges line up perfectly, precisely, every time. Makes installation easier and faster.



**DUST-FREE (MEDICAL)
BEARINGS**

Prevent metal-to-metal contact and eliminate dust. Exclusive standard (no upcharge) on all SELECT Pin & Barrel hinges.



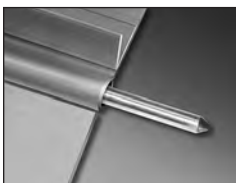
VARIETY OF FINISHES

Available in polished, brushed and painted finishes to match, contrast or accent your building's design.



3-HR. FIRE RATING

Fire-rated out of the package. No extra parts to buy or install. No liability worries.



STAINLESS STEEL PIN

Delivers high tensile strength by forming a strong, free-moving unit. Flexible and strong in abused openings.



END CAPS

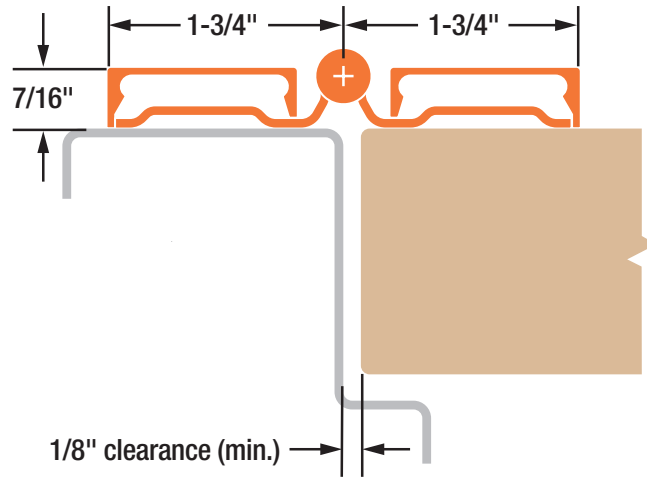
Spiral-knurled steel caps seal the barrel ends to contain hinge pin.

SELECT HINGE PERFORMANCE

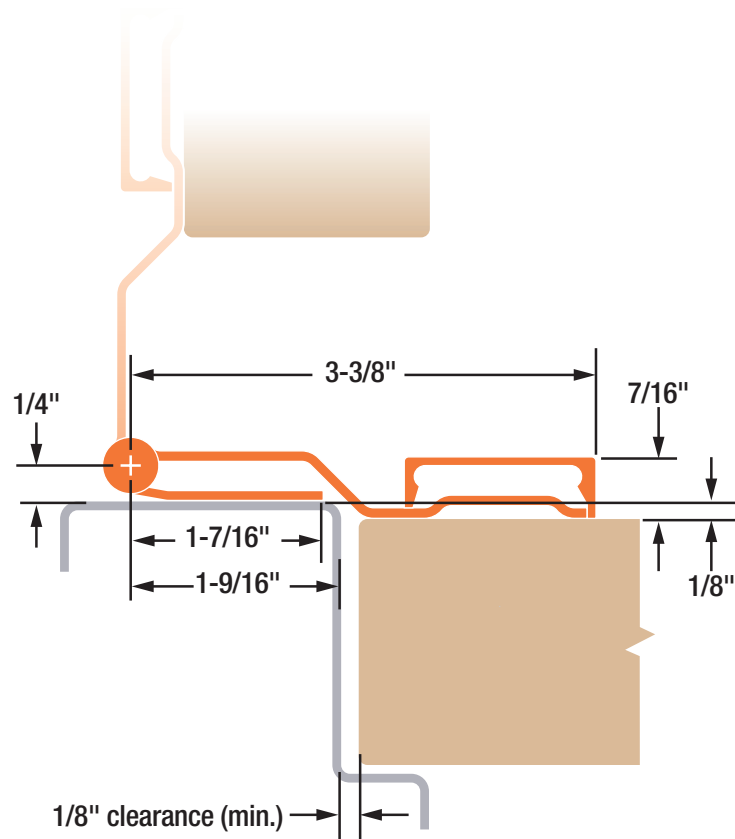
- SELECT pin & barrel continuous hinges are built to handle abuse from high-traffic applications. They are applied to the surface on the edge of the frame and door. No machining or reinforcement is required.
- On conventional hinges, opening and “kick-back” energy concentrate on a few inches of fastened reinforcing plate — with the top hinge handling 100% of the force. Pinless SELECT hinges bond the door and frame into an integrated, sag-free unit. “Kick-back” energy dissipates along the entire length of the door and frame. (Compare this to a conventional hinge’s 4-1/2" to 5" at the top of the door and frame).
- SELECT pin & barrel continuous hinges eliminate the gap between the door and frame, providing a weatherproof, rust-proof, tamper-proof barrier.
- SELECT pin & barrel continuous hinges (excluding Toilet Partition hinges) are listed and tested by Underwriters Laboratories to meet the Positive pressure requirements of UL10C, and are in accordance with UBC 7.2 (1997). SELECT pin & barrel continuous hinges (excluding Toilet Partition hinges) are for use on swinging single fire doors (max. door opening of 4'x10') or pairs of fire doors (max. door opening of 8' x10'), including double egress, installed in masonry or drywall. SELECT pin & barrel continuous hinges (excluding Toilet Partition hinges) are rated for 20 minutes on labeled wood doors, 1-1/2 hours for labeled hollow metal and composite-core wood fire doors, and 3 hours (NO FIRE PINS OR STUDS REQUIRED) for labeled hollow metal doors mounted singly only.



SL302



SL309



FULL SURFACE P&B CONTINUOUS HINGES

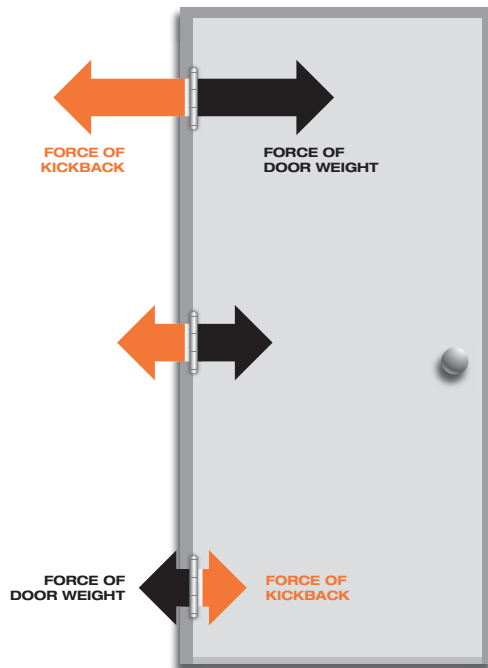


HINGE PART NUMBER INTERCHANGE: PIN & BARREL HINGES

SELECT MODELS	MARKAR	HAGER	PEMKO	MCKINNEY	STANLEY	ABH	IVES
SL302	FS-302		SPBFS	MCK FS302	657	A502	702
SL309	FS/SC-309	790-909	SPBFSSC	MCK FS309			

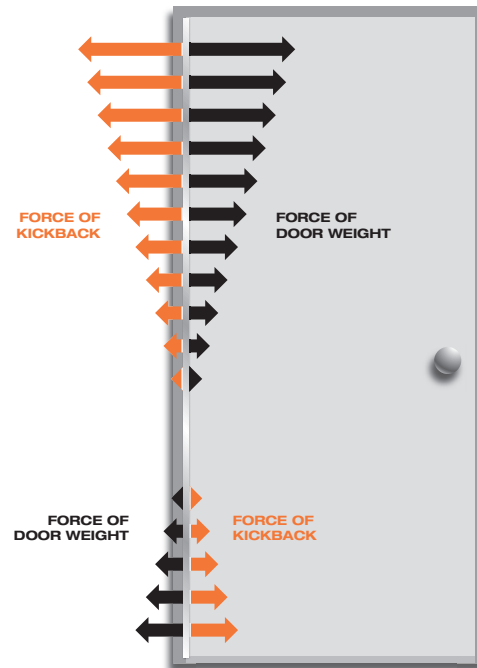
No equivalent hinge available from this manufacturer.

HINGE STRESS COMPARISON



CONVENTIONAL BUTT HINGES

On conventional hinges, opening and “kickback” energy from closers and automatic operators concentrates on the top butt hinge. This force works against the top hinge, eventually forcing it apart or pulling it from the frame/door.



CONTINUOUS HINGES

SELECT continuous hinges unite the door and frame into an integrated, sag-free unit. “Kickback” energy dissipates along the entire length of the door and frame and prevents hinge failure.

INSTALLATION INSTRUCTIONS

Full Surface Pin and Barrel Continuous Hinge

SL302



PRODUCT MUST BE INSTALLED ACCORDING TO ALL APPLICABLE BUILDING AND LIFE SAFETY CODES

All holes in door and frame must be drilled correctly and fasteners properly installed. Failure to use fasteners supplied by Select Products Limited will void UL or WHI fire rated listing.

Important Warranty Information:

The following actions will void any warranty, expressed or implied:

- Failure to install the hinge according to the manufacturer's specifications and requirements. (for more information, visit selecthingerequirements.com)
- Use of fasteners other than those supplied with the hinge.
- Unauthorized field modifications, including alteration of the original finish or painting the hinge.

Do Not install Snap-On Cover until installation is 100% complete, and all aspects of the assembly are correctly fastened and properly fitted. The cover is impossible to remove without damage and replacement may be necessary.

Perform each step of the following instructions:

1. Frame Preparation and Mounting

- A. Place hinge on frame as shown (Fig. 1) allowing for 1/8" between top of hinge and underside of header.

Note: 1-5/8" min of frame face is required for mounting this hinge.

- B. Mark the position of the top and bottom holes with a center punch, then drill and fasten with the #12-24 x 11/16" Flat Head Undercut Self-Drilling Screws. The use of the center punch can help center the hole so that the fasteners will enter straight.

- C. After the top and bottom screws are installed, drill and fasten the balance of the holes. Install at least five cover clips by passing a screw through the clip, hinge leaf and frame (Fig. 2).

It is recommended that clips be positioned in the top, center and bottom holes, with the remaining clips spaced equally along the length of the hinge










2. Door Preparation and Mounting

- A. Fold the door leaf back over the frame leaf and place the door in the door frame.
- B. Place shims under the door to provide 1/8" clearance between the header and top of the door.
- C. Add shims at both the hinge and latch side of the door so that 1/8" clearance will be maintained on the lock side of the door.
- D. With the door held firmly in place, return the door leaf to the face of the door and repeat the drilling procedure described in steps (1B) and (1C) above, but using the 1/4-20 x 3/4" Torx Pan Head Self-Drilling Screws.
- E. Install the Snap-On covers by engaging the side of the cover next to the hinge pin first.

- F. Insert a large screwdriver between the hinge knuckle and the cover. Using the screwdriver as a lever, twist it and snap the opposite side of the cover onto the clip.

- G. Start at the top and work downward until the entire length of each cover is firmly engaged.

- H. With the covers firmly in place, secure them at both ends through the hinge and into the door and frame with #8 x 3/4" Flat Head Undercut Self-Drilling Screws.

STANDARD HARDWARE	
	
1/4-20 X 3/4" TORX PAN HEAD SELF-DRILLING SCREW (TKS14075R)	
	
#12-24 X 11/16" FLAT HEAD UNDERCUT SELF-DRILLING SCREW (TKS1267SP10SS)	
	
#8 X 3/4" FLAT HEAD UNDERCUT SELF-DRILLING SCREW (TKS8075Z)	
	
COVER CLIP (606 M22-0130-01)	
OPTIONAL HARDWARE AVAILABLE UPON REQUEST	
	
#12-8 x 1-1/2" FLAT HEAD UNDERCUT WOOD SCREW (PBS12150SP10SS)	
SECURITY SCREWPACK M91-0063-630	

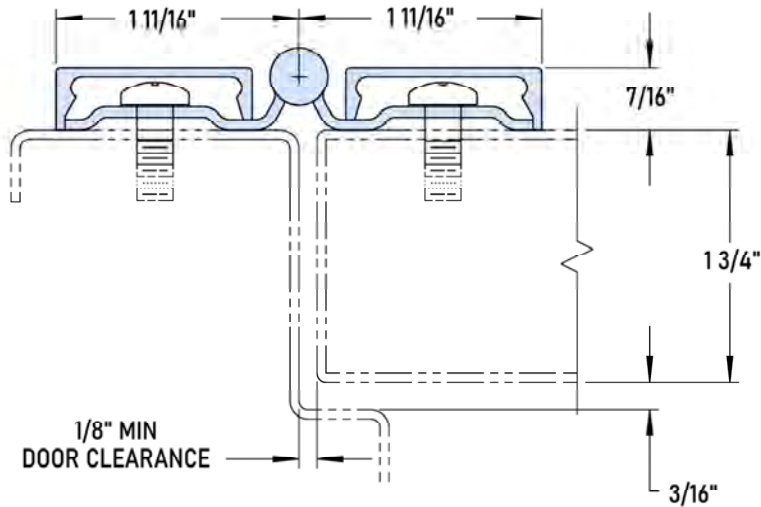


Fig. 1

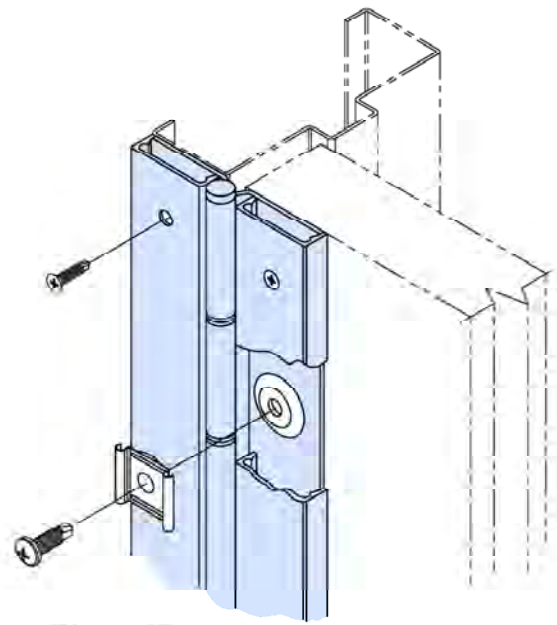


Fig. 2

Model SL302
 Standard "Non-Adjustable" application clearances

Clearance (A)	Total Under-Sizing Required	
	Single Door	Pair of Doors
1/8"	5/16"	7/16"

+ 1/16" Frame Irregularity

+ 1/16" Frame Irregularity



SELECT HINGES
 SELECT Products Limited

3258 Stadium Park Way
 Kalamazoo, MI 49009
 PH: 800-423-1174
 Fax: 800-423-7107
 www.select-hinges.com

INSTALLATION INSTRUCTIONS

Full Surface Pin and Barrel Continuous Hinge

SL309



PRODUCT MUST BE INSTALLED ACCORDING TO ALL APPLICABLE BUILDING AND LIFE SAFETY CODES

All holes in door and frame must be drilled correctly and fasteners properly installed. Failure to use fasteners supplied by Select Products Limited will void UL or WHI fire rated listing.

Important Warranty Information:

The following actions will void any warranty, expressed or implied:

- Failure to install the hinge according to the manufacturer's specifications and requirements. (for more information, visit selecthingerequirements.com)
- Use of fasteners other than those supplied with the hinge.
- Unauthorized field modifications, including alteration of the original finish or painting the hinge.

1. Frame Preparation and Mounting






- A. Place hinge on frame as shown (Fig. 1) allowing for 1/8" between top of hinge and underside of header.
- B. Mark the position of the top and bottom holes with a center punch, then drill and fasten. The use of the center punch can help center the hole so that the fasteners will enter straight.
- C. After the top and bottom screws are installed, drill and fasten the balance of the holes.

2. Door Preparation and Mounting

- A. Fold the door leaf back over the frame leaf and place the door in the door frame.
- B. Place shims under the door to provide 1/8" clearance between the header and top of the door.
- C. Add shims at both the hinge and latch side of the door so that 1/8" clearance will be maintained on the lock side of the door.
- D. With the door held firmly in place, return the door leaf to the face of the door and repeat the drilling procedure described in steps (1B) and (1C) above.
- E. Install five cover clips by passing a screw through the clip, hinge leaf and door (Fig. 2).

It is recommended that clips be positioned in the top, center and bottom holes, with the remaining clips spaced equally along the length of the hinge

- F. Install the Snap-On covers by engaging the side of the cover next to the hinge pin first.
- G. Insert a large screwdriver between the hinge knuckle and the cover. Using the screwdriver as a lever, twist it and snap the opposite side of the cover onto the clip.
- H. Start at the top and work downward until the entire length of each cover is firmly engaged.
- I. With the covers firmly in place, secure them at both ends through the hinge and into the door and frame with #8 x 3/4" Flat Head Undercut Self-Drilling Screws.

STANDARD HARDWARE
 <p>1/4-20 X 3/4" TORX PAN HEAD SELF-DRILLING SCREW (TKS14075R)</p>
 <p>#12-24 X 11/16" FLAT HEAD UNDERCUT SELF-DRILLING SCREW (TKS1267SP10SS)</p>
 <p>#8 X 3/4" FLAT HEAD UNDERCUT SELF-DRILLING SCREW (TKS8075Z)</p>
 <p>COVER CLIP (606 M22-0130-01)</p>
OPTIONAL HARDWARE AVAILABLE UPON REQUEST
 <p>#12-8 x 1-1/2" FLAT HEAD UNDERCUT WOOD SCREW (PBS12150SP10SS)</p>
<p>SCREWPACK KMSSS AND SECURITY SCREWPACKS M91-0031MM, M91-0031WW, M91-0063-630</p>

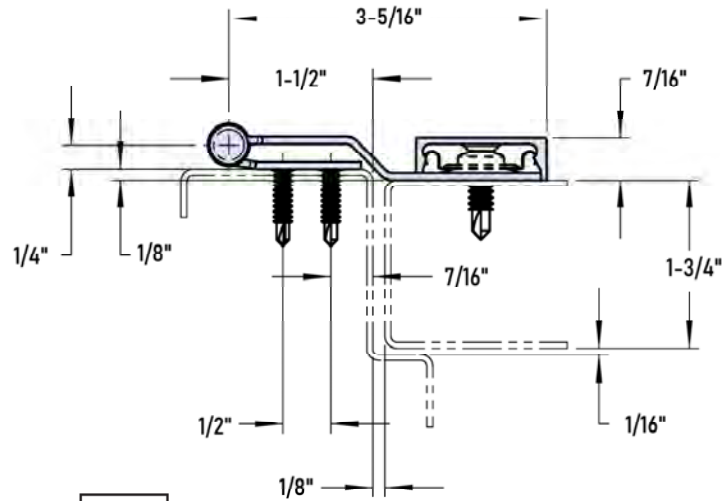


Fig. 1

Model SL309

Standard "Non-Adjustable" application clearances

Total Under-Sizing Required

Clearance (A)	Single Door	Pair of Doors
1/8"	5/16"	7/16"

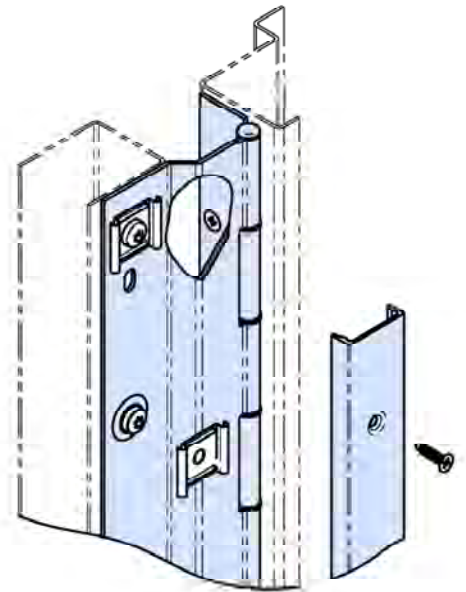
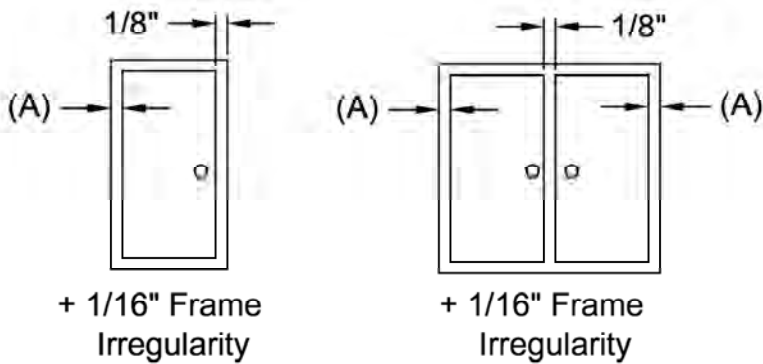


Fig. 2



SELECT HINGES[®]

SELECT Products Limited

3258 Stadium Park Way

Kalamazoo, MI 49009

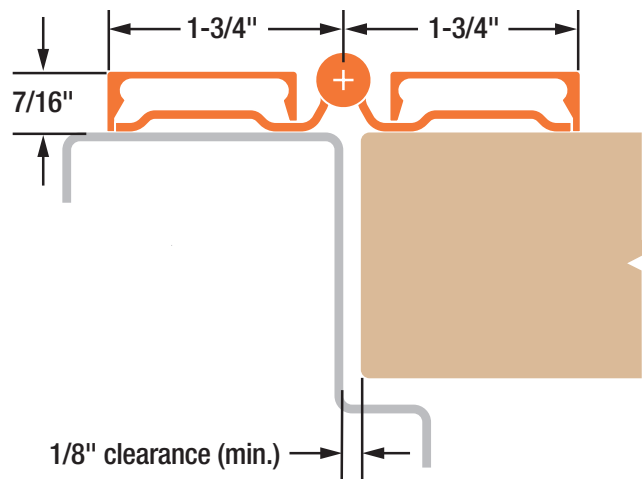
PH: 800-423-1174

Fax: 800-423-7107

www.select-hinges.com



- Stainless steel
- Center pivot
- Tamper-resistant leaf covers
- Flush mounted (no door inset)
- For 1-3/4" doors weighing up to 600 lb.
- 48" maximum door width



SL302

SL302

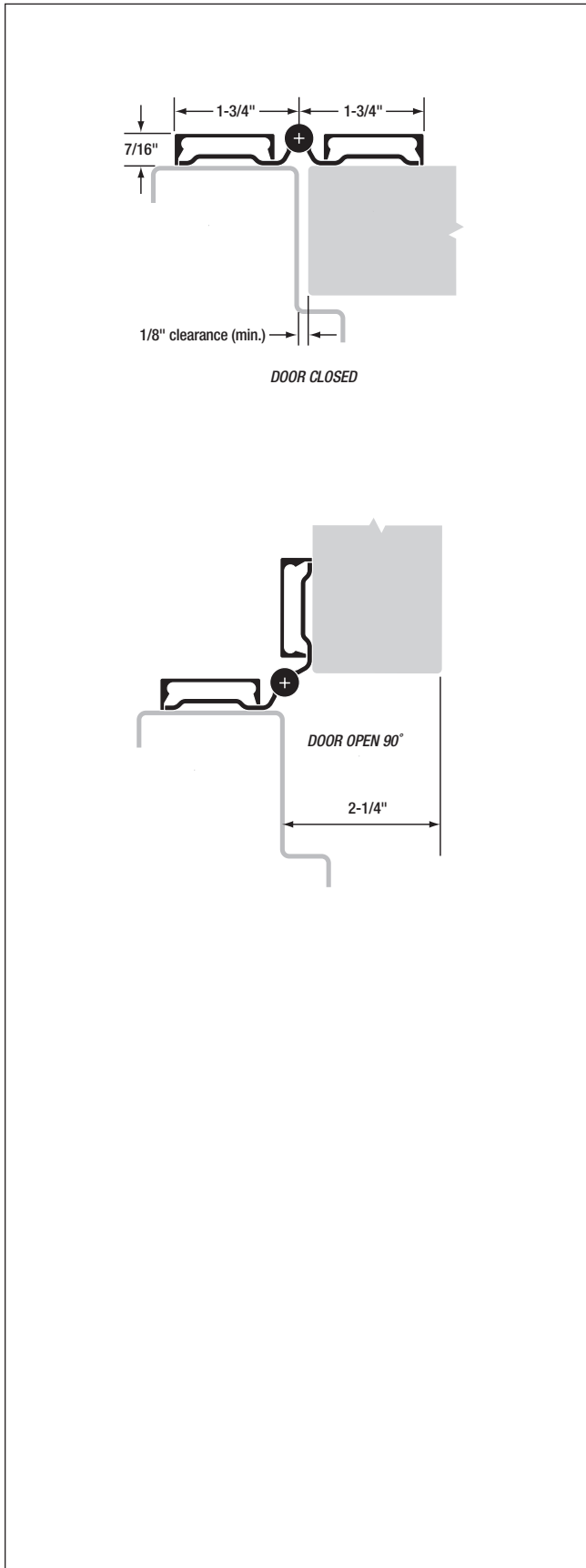
Full Surface Pin & Barrel Continuous Hinge



SL302

NOTES:

SL302 Full Surface Pin & Barrel Hinge



MATERIAL: 14 gauge 304 stainless steel barrel with 3/16" diameter 304 stainless pin. Long-life nylon medical bearings.

LENGTHS: 79", 83", 85", 95" and 119" lengths standard for nominal door heights. Custom lengths are available.

LOAD/FREQUENCY: For 1-3/4" doors, 48" wide (max.), weighing up to 400 pounds (medium-frequency) without frame or door reinforcement; up to 600 pounds (low-frequency) without frame or door reinforcement.

FINISH: US32D satin stainless steel (630).

CLOSERS: Conventional overhead surface, concealed sliding arm overhead or floor closers may be used with SELECT hinges. Pivot-type floor closers (with a fixed, conflicting center pivot) must be replaced.

ORDER: Specify hinge length. Screw pack contains 1/4-20 x 3/4" zinc plated Torx® panhead self-drilling Tek® screws, 8 x 3/4" zinc plated Phillips flathead undercut self-drilling Tek® screws and zinc plated cover clips.



SL302 HINGE SCREW COUNT		
HINGE LENGTH	DOOR SCREWS	FRAME SCREWS
79"	13	13
83"	14	14
85"	14	14
95"	16	16
119"	20	20

SPECIFICATIONS

SL302 Full Surface Pin & Barrel Hinge



SELECT ADVANTAGES



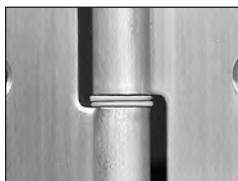
CORROSION-RESISTANT STAINLESS STEEL

Stainless steel pin & barrel design creates a tough, highly secure opening.



TEMPLATED HOLE PATTERN

SELECT hinges line up perfectly, precisely, every time. Makes installation easier and faster.



DUST-FREE (MEDICAL) BEARINGS

Prevent metal-to-metal contact and eliminate dust. Exclusive standard (no upcharge) on all SELECT Pin & Barrel hinges.



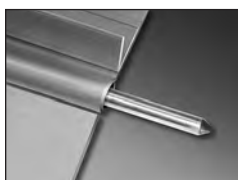
VARIETY OF FINISHES

Available in polished, brushed and painted finishes to match, contrast or accent your building's design.



3-HR. FIRE RATING

Fire-rated out of the package. No extra parts to buy or install. No liability worries.



STAINLESS STEEL PIN

Delivers high tensile strength by forming a strong, free-moving unit. Flexible and strong in abused openings.



END CAPS

Spiral-knurled steel caps seal the barrel ends to contain hinge pin.

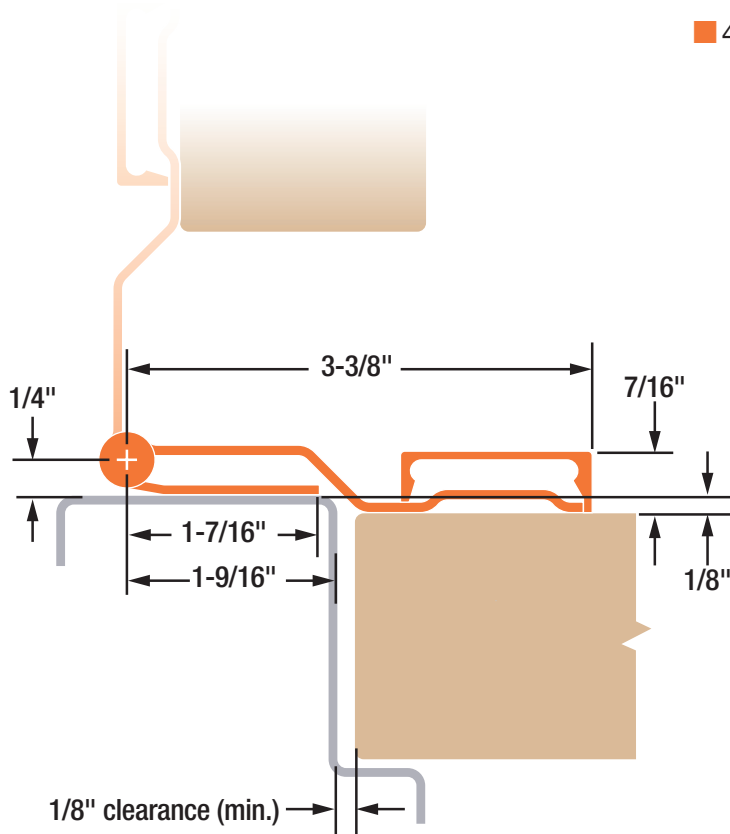
SELECT HINGE PERFORMANCE

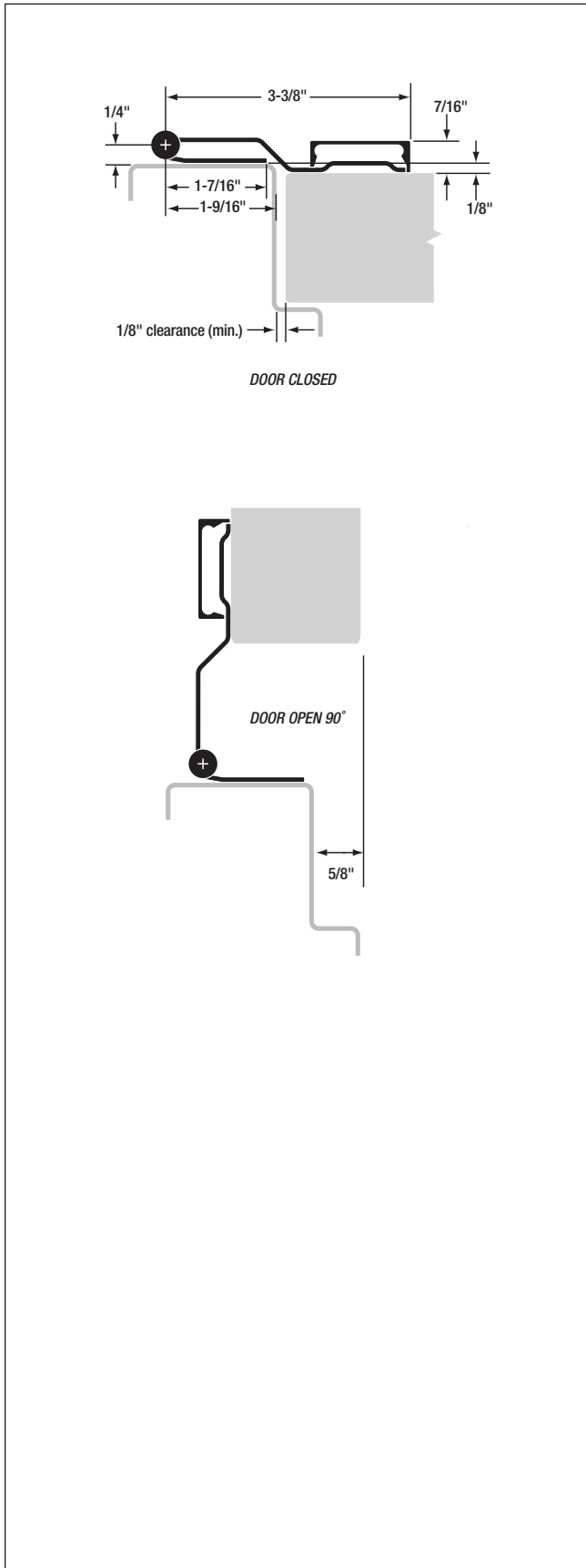
- SELECT pin & barrel continuous hinges are built to handle abuse from high-traffic applications. They are applied to the surface on the edge of the frame and door. No machining or reinforcement is required.
- On conventional hinges, opening and “kick-back” energy concentrate on a few inches of fastened reinforcing plate — with the top hinge handling 100% of the force. Pinless SELECT hinges bond the door and frame into an integrated, sag-free unit. “Kick-back” energy dissipates along the entire length of the door and frame. (Compare this to a conventional hinge’s 4-1/2" to 5" at the top of the door and frame).
- SELECT pin & barrel continuous hinges eliminate the gap between the door and frame, providing a weatherproof, rust-proof, tamper-proof barrier.
- SELECT pin & barrel continuous hinges (excluding Toilet Partition hinges) are listed and tested by Underwriters Laboratories to meet the Positive pressure requirements of UL10C, and are in accordance with UBC 7.2 (1997). SELECT pin & barrel continuous hinges (excluding Toilet Partition hinges) are for use on swinging single fire doors (max. door opening of 4'x10') or pairs of fire doors (max. door opening of 8' x10'), including double egress, installed in masonry or drywall. SELECT pin & barrel continuous hinges (excluding Toilet Partition hinges) are rated for 20 minutes on labeled wood doors, 1-1/2 hours for labeled hollow metal and composite-core wood fire doors, and 3 hours (NO FIRE PINS OR STUDS REQUIRED) for labeled hollow metal doors mounted singly only.





- Stainless steel
- Swing-clear action
- Tamper-resistant door leaf cover
- 1/8" door inset
- For 1-3/4" doors weighing up to 600 lb.
- 48" maximum door width



SL309 Full Surface Pin & Barrel Hinge


MATERIAL: 14 gauge 304 stainless steel barrel with 3/16" diameter 304 stainless pin. Long-life nylon medical bearings.

LENGTHS: 79", 83", 85", 95" and 119" lengths standard for nominal door heights. Custom lengths are available.

LOAD/FREQUENCY: For 1-3/4" doors, 48" wide (max.), weighing up to 400 pounds (medium-frequency) without frame or door reinforcement; up to 600 pounds (low-frequency) without frame or door reinforcement.

FINISH: US32D satin stainless steel (630).

CLOSERS: Conventional overhead surface, concealed sliding arm overhead or floor closers may be used with SELECT hinges. Pivot-type floor closers (with a fixed, conflicting center pivot) must be replaced.

ORDER: Specify hinge length. Screw pack contains 12-24 x 7/8" 410SS Phillips flathead undercut self-drilling Tek® screws, 10 x 1-1/4" 410SS Phillips flathead undercut sheet metal screws, 1/4-20 x 3/4" zinc plated Torx® panhead self-drilling Tek® screws, 8 x 3/4" zinc plated Phillips flathead undercut self-drilling Tek® screws and zinc plated cover clips.



SL309 HINGE SCREW COUNT		
HINGE LENGTH	DOOR SCREWS	FRAME SCREWS
79"	13	18
83"	14	21
85"	14	18
95"	16	23
119"	20	27

SPECIFICATIONS

SL309 Full Surface Pin & Barrel Hinge



SELECT ADVANTAGES



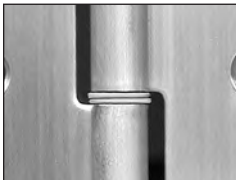
CORROSION-RESISTANT STAINLESS STEEL

Stainless steel pin & barrel design creates a tough, highly secure opening.



TEMPLATED HOLE PATTERN

SELECT hinges line up perfectly, precisely, every time. Makes installation easier and faster.



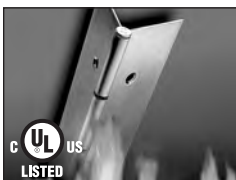
DUST-FREE (MEDICAL) BEARINGS

Prevent metal-to-metal contact and eliminate dust. Exclusive standard (no upcharge) on all SELECT Pin & Barrel hinges.



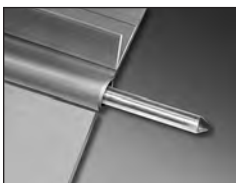
VARIETY OF FINISHES

Available in polished, brushed and painted finishes to match, contrast or accent your building's design.



3-HR. FIRE RATING

Fire-rated out of the package. No extra parts to buy or install. No liability worries.



STAINLESS STEEL PIN

Delivers high tensile strength by forming a strong, free-moving unit. Flexible and strong in abused openings.



END CAPS

Spiral-knurled steel caps seal the barrel ends to contain hinge pin.

SELECT HINGE PERFORMANCE

- SELECT pin & barrel continuous hinges are built to handle abuse from high-traffic applications. They are applied to the surface on the edge of the frame and door. No machining or reinforcement is required.
- On conventional hinges, opening and “kick-back” energy concentrate on a few inches of fastened reinforcing plate — with the top hinge handling 100% of the force. Pinless SELECT hinges bond the door and frame into an integrated, sag-free unit. “Kick-back” energy dissipates along the entire length of the door and frame. (Compare this to a conventional hinge’s 4-1/2" to 5" at the top of the door and frame).
- SELECT pin & barrel continuous hinges eliminate the gap between the door and frame, providing a weatherproof, rust-proof, tamper-proof barrier.
- SELECT pin & barrel continuous hinges (excluding Toilet Partition hinges) are listed and tested by Underwriters Laboratories to meet the Positive pressure requirements of UL10C, and are in accordance with UBC 7.2 (1997). SELECT pin & barrel continuous hinges (excluding Toilet Partition hinges) are for use on swinging single fire doors (max. door opening of 4'x10') or pairs of fire doors (max. door opening of 8' x10'), including double egress, installed in masonry or drywall. SELECT pin & barrel continuous hinges (excluding Toilet Partition hinges) are rated for 20 minutes on labeled wood doors, 1-1/2 hours for labeled hollow metal and composite-core wood fire doors, and 3 hours (NO FIRE PINS OR STUDS REQUIRED) for labeled hollow metal doors mounted singly only.



Geared
SL60/62



Pin & Barrel
SL402TP



SL902TP



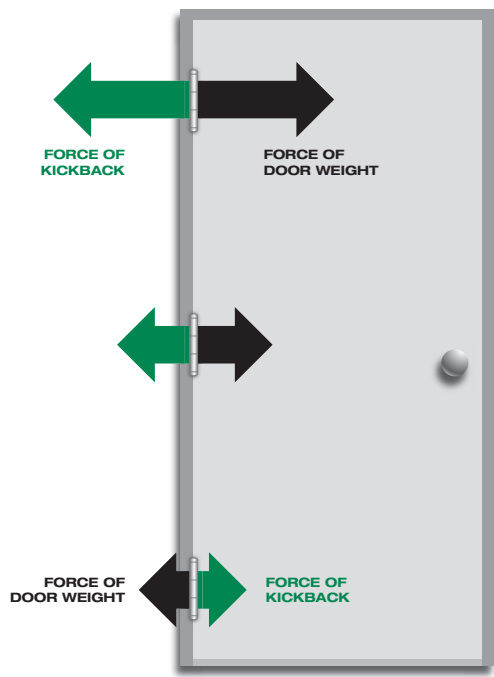
TOILET PARTITION HINGES

HINGE PART NUMBER INTERCHANGE: TOILET PARTITION HINGES

SELECT MODELS	MARKAR	HAGER	PEMKO	MCKINNEY	STANLEY	ABH	IVES
SL60							
SL62							
SL402	FS-402-TP						
SL902	FS-902-TP						

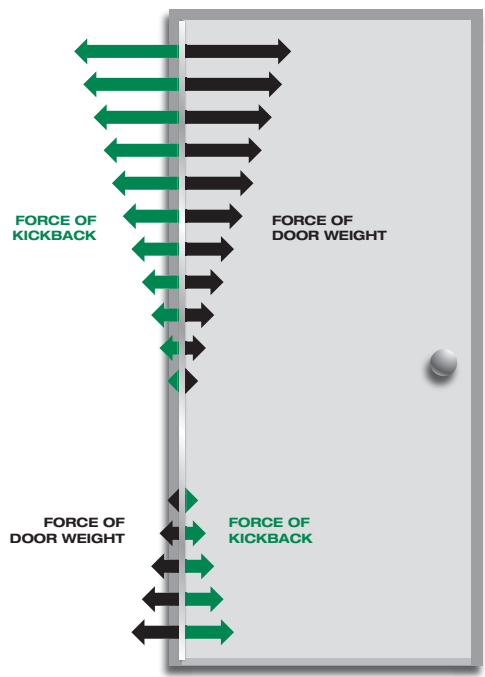
No equivalent hinge available from this manufacturer.

HINGE STRESS COMPARISON



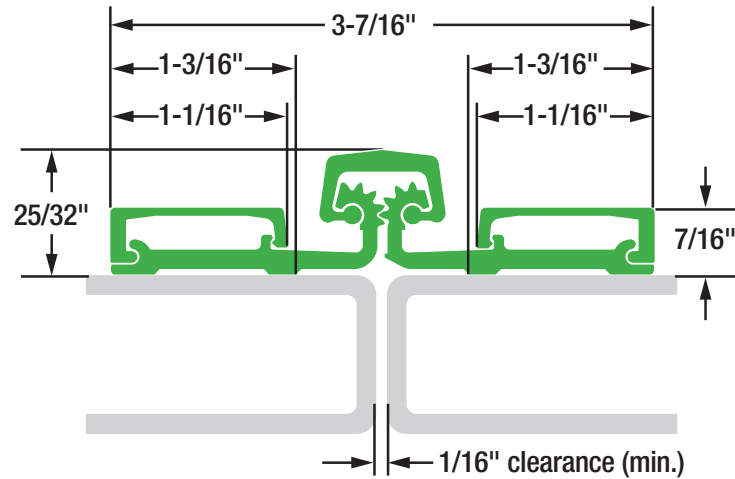
CONVENTIONAL BUTT HINGES

On conventional hinges, opening and “kickback” energy from closers and automatic operators concentrates on the top butt hinge. This force works against the top hinge, eventually forcing it apart or pulling it from the frame/door.



CONTINUOUS HINGES

SELECT continuous hinges unite the door and frame into an integrated, sag-free unit. “Kickback” energy dissipates along the entire length of the door and frame and prevents hinge failure.

SL60/62

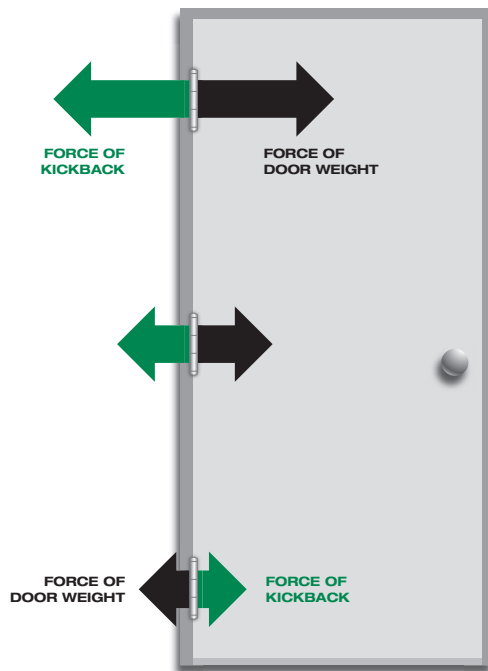
GEARED TOILET PARTITION HINGES

HINGE PART NUMBER INTERCHANGE: TOILET PARTITION HINGES

SELECT MODELS	MARKAR	HAGER	PEMKO	MCKINNEY	STANLEY	ABH	IVES
SL60							
SL62							

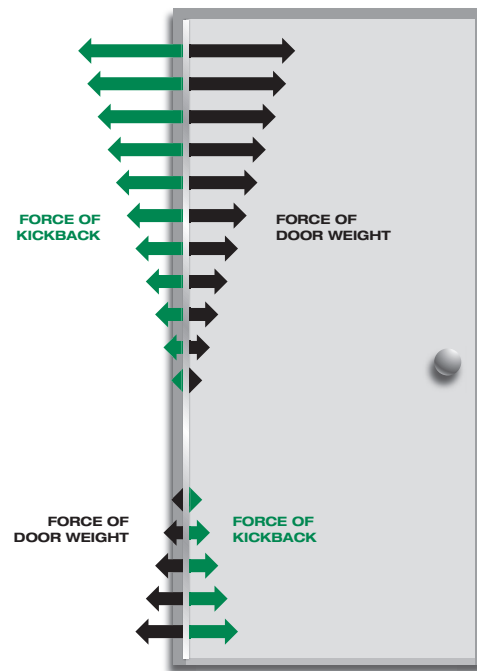
No equivalent hinge available from this manufacturer.

HINGE STRESS COMPARISON



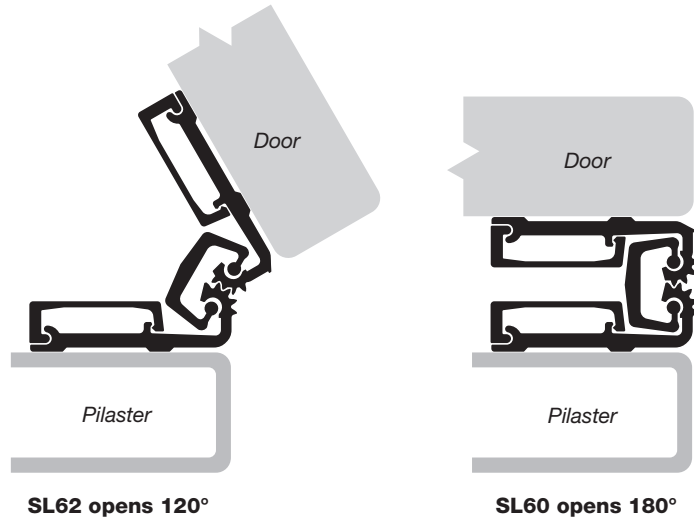
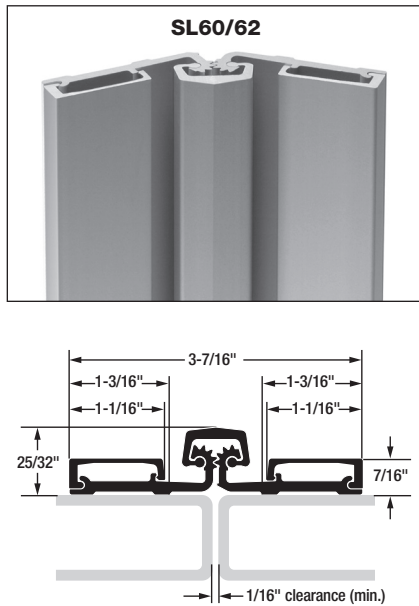
CONVENTIONAL BUTT HINGES

On conventional hinges, opening and “kickback” energy from closers and automatic operators concentrates on the top butt hinge. This force works against the top hinge, eventually forcing it apart or pulling it from the frame/door.



CONTINUOUS HINGES

SELECT continuous hinges unite the door and frame into an integrated, sag-free unit. “Kickback” energy dissipates along the entire length of the door and frame and prevents hinge failure.



Choice of standard or self-closing.
 SL60 Standard Model opens 180°.
 SL62 Self-Closing Model opens 120°.

Calculating Required Door Clearances

IMPORTANT: All standard length SELECT hinges are supplied slightly shorter than nominal door height to avoid threshold or flooring clearance problems.

IMPORTANT: SL60 and SL62 hinges are non-handed and templated, and remain non-handed after cutting.

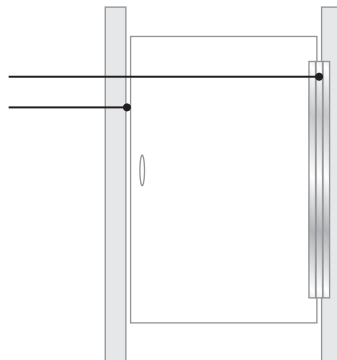
IMPORTANT: When installing Model SL62 Self-Closing Hinge, you must level or plumb the pilaster within + or - 1/8" to ensure complete door closure.

TOILET PARTITION DOOR:

Hinge side clearance 1/16" – 1/4"

Latch side clearance 1/16" – 3/8"

Total Width Clearance 1/8" – 5/8"



Important Warranty Information:

The following actions will void any warranty, expressed or implied:

- Failure to install the hinge according to manufacturer's specifications and requirements. (For more information, visit selecthingerequirements.com.)
- Use of fasteners other than those supplied with the hinge.
- Unauthorized field modifications, including alteration or removal of the factory-applied lubricant, altering the original finish or painting the hinge.

Tools Needed

- Metal-cutting saw
- Tape measure
- Drill
- 1/4" drill bit
- Transfer punch or pencil
- 5/64" Allen wrench
- Hammer
- Shims

Parts Supplied

- 10-24 x 5/8" one-way barrel nuts (sexnuts)
- Set screws

Optional Parts

- 10-24 one-way shoulder screws available for 3/4", 1" and 1-1/4" thick partitions
- Protective gloves are recommended

How to Cut the Hinge to Fit

- A. Keep hinge in "door closed" position (Fig. 1).
- B. Using a metal-cutting saw, begin the cut through the hinge cap first.
NOTE: DO NOT cut through a set screw bearing.
- C. Loosen set screws from sides of leaf covers with 5/64" Allen wrench (Fig. 1).
- D. Remove leaf covers by sliding them off uncut end of hinge.
- E. Reinstall any set screw bearing that may have been cut off.

A. Attach Hinge to Pilaster

NOTE: Remove leaf covers if not already removed. See step C above.

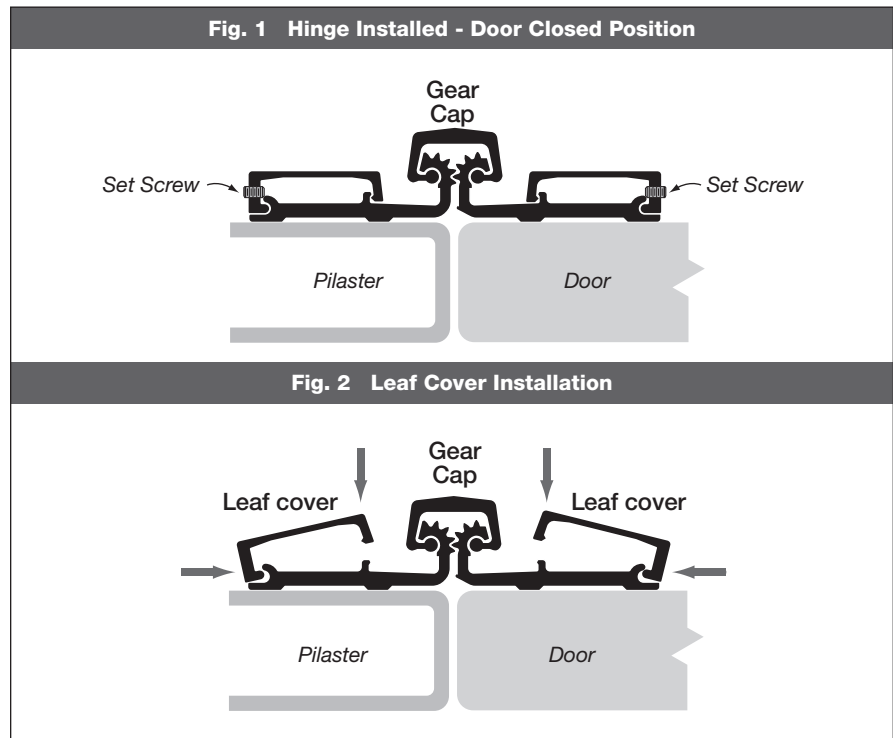
1. Align hinge with door-side edge of pilaster or alignment line. If replacing pivots, center the hinge between pilaster's pivot cutouts.
2. Locate top hole for the barrel nut in the pilaster. Keep hinge centered between pivot cutouts. Using a pencil or transfer punch, mark the hole.

NOTE: Hinge leaf should overlap pilaster by 1-1/2" to 1-5/8".

3. Remove hinge. Using 1/4" bit, drill top hole in pilaster.
4. Fasten hinge leaf to top of pilaster using a barrel nut and shoulder screw.

IMPORTANT: DO NOT fully tighten the one-way screw.

5. Square hinge to the pilaster. Locate bottom hole on the pilaster. Mark (or centerpunch) hole.



6. Drill the hole using 1/4" bit.
7. Fasten hinge leaf to bottom of the pilaster using a barrel nut and shoulder screw.

IMPORTANT: Do NOT fully tighten the one-way screws at this time. Do NOT drill remaining holes at this time.

B. Prepare Door

NOTE: If a door inset is required, use a continuous shim under the door leaf.

8. Place door in opening. Adjust for 1/16" to 1/4" clearance between the hinge edge of the door and the pilaster. If replacing pivots, center the hinge between door's pivot cutouts.

NOTE: Hinge leaf should overlap the door by 1-1/2" to 1-5/8" to allow 1/16" to 3/8" clearance on the latch side.

9. Locate top hole for the barrel nut in the door. Mark (or centerpunch) top hole.
10. Remove door from opening and lay it flat. Use 1/4" bit to drill the hole.

C. Attach Door to Hinge

11. Fasten the hinge door leaf to the top of the door using a barrel nut and shoulder screw.

IMPORTANT: Do NOT fully tighten the one-way screw at this time.

12. Square the door to the opening. Then locate the bottom hole for the door hinge leaf. Mark (or centerpunch) the hole.
13. Drill the hole using 1/4" drill bit.
14. Fasten hinge door leaf to the bottom of the door using a barrel nut and shoulder screw. Door should be centered in the opening and square to the pilaster.

IMPORTANT: Do NOT fully tighten the one-way screws at this time.

15. Check that the door and hinge are square and function properly. Use 1/4" bit to drill remaining holes through hinge into the pilaster and door.
16. Install remaining barrel nuts and shoulder screws. Check door operation. If the door functions properly, fully tighten all screws.

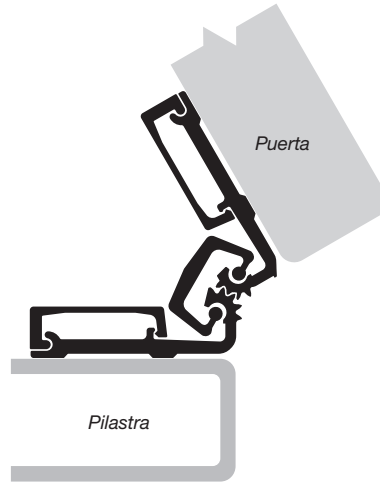
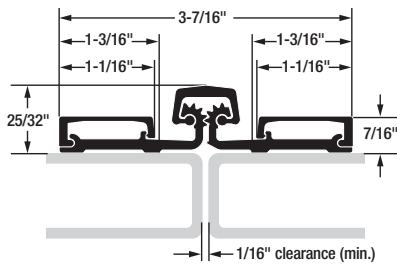
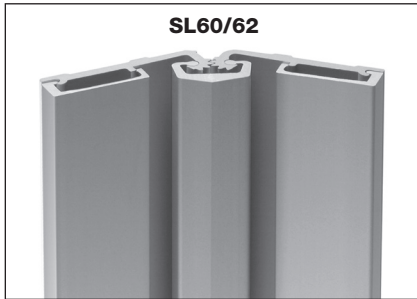
D. Install Leaf Covers

17. Align leaf cover with top end of hinge.
18. Starting from the top and working downward, apply pressure to leaf cover to snap it into place (Fig. 2).

NOTE: If you use a hammer to tap cover into place, be sure to protect the surface of the cover from damage.

19. Tighten set screws with 5/64" Allen wrench.

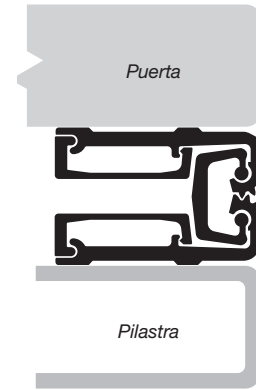
NOTE: The door and pilaster covers can be removed and reinstalled.


SL62 se abre a 120°

Se puede elegir entre el modelo estándar o el modelo con cierre automático.

El modelo SL60 estándar se abre a 180°.

El modelo SL62 con cierre automático se abre a 120°.


SL60 se abre a 180°

Cálculo de las tolerancias requeridas para la puerta

IMPORTANTE: Todas las charnelas SELECT de longitud estándar se suministran un poco más pequeñas que la altura nominal de la puerta, para evitar problemas de tolerancia en el umbral o el piso.

IMPORTANTE: Las charnelas SL60 y SL62 pueden usarse por diestros o zurdos y están templadas, permaneciendo con la opción de usarse ya sea con la mano derecha o la mano izquierda después del corte.

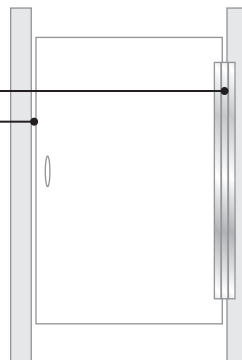
IMPORTANTE: Cuando instale el modelo de charnela de cierre automático SL62, debe nivelar o usar una plomada para la pilastra dentro de $\pm 1/8$ " para asegurar el cierre total de la puerta.

PUERTA DE LA PARED DIVISORIA DEL INODORO:

Tolerancia lateral de la charnela 1/16" – 1/4"

Tolerancia lateral del cerrojo 1/16" – 3/8"

Tolerancia de ancho total 1/8" – 5/8"



Información importante sobre la garantía:

Las siguientes acciones anularán cualquier garantía, expresa o implícita:

- El no instalar la bisagra según las especificaciones y los requisitos del fabricante. (Para obtener más información, visite selecthingerequirements.com.)
- Uso de sujetadores que no sean los que se suministran con la charnela.
- Modificaciones de campo no autorizadas, incluyendo la alteración o eliminación del lubricante aplicado de fábrica, alterar el acabado original o pintar la charnela.

Herramientas necesarias

- Sierra para cortar metal
- Cinta para medir
- Taladro
- Broca de 1/4"
- Punzón o lápiz de transferencia
- Llave Allen de 5/64"
- Martillo
- Cuñas

Piezas suministradas

- Tuercas cilíndricas unidireccionales N° 10-24 x 5/8"
- Tornillos de ajuste

Piezas opcionales

- Tornillos de tope unidireccionales N° 10-24 disponibles para paredes divisorias de 3/4", 1" y 1 1/4" de espesor
- Se recomienda el uso de guantes protectores

Cómo cortar la charnela al tamaño

- A. Mantenga la charnela en la posición de "puerta cerrada" (Fig.1).
- B. Usando una sierra para cortar metal, comience a cortar primero por la tapa de la charnela.

NOTA: NO corte por el rodamiento del tornillo de ajuste.

- C. Afloje los tornillos de ajuste de los lados de las cubiertas de la hoja con una llave Allen de 5/64" (Fig. 1).
- D. Quite las cubiertas de la hoja deslizándolas por el extremo sin cortar de la charnela.
- E. Vuelva a instalar cualquier rodamiento de los tornillos de ajuste que pudiera haberse cortado.

A. Fije la charnela a la pilastra

NOTA: Retire las cubiertas de la hoja si no lo ha hecho todavía. Vea el paso C arriba.

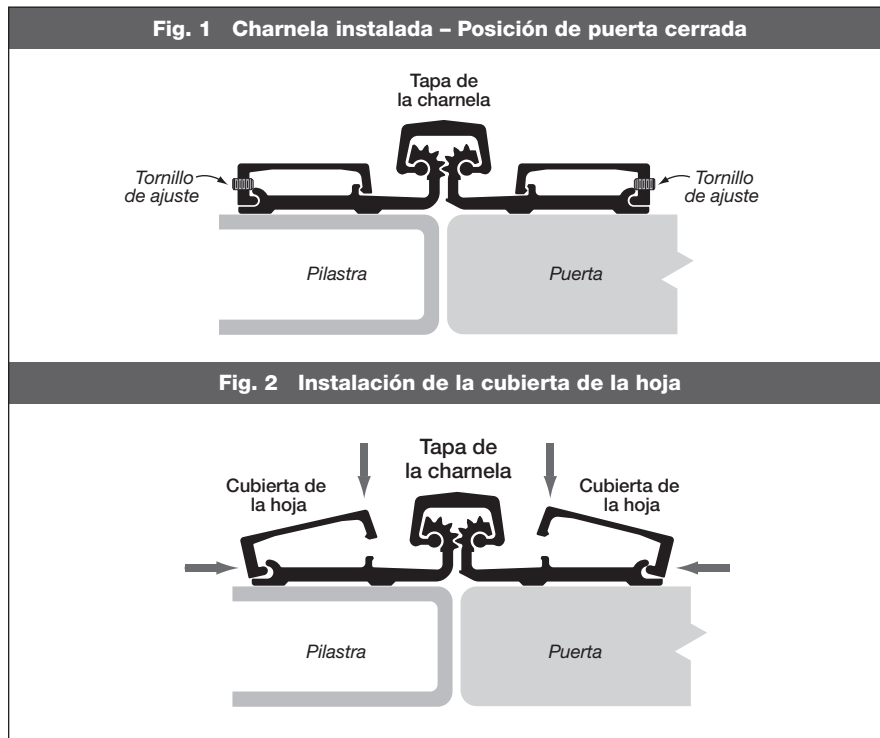
1. Alinee la charnela con el borde lateral de la puerta de la pilastra o la línea de alineación. Si está reemplazando los pivotes, centre la charnela entre los recortes de pivote de la pilastra.
2. Ubique el orificio superior para la tuerca cilíndrica en la pilastra. Mantenga la charnela centrada entre los recortes de pivote. Usando un lápiz o un punzón, marque el orificio.

NOTA: La hoja de la charnela debe superponerse a la pilastra 1 1/2" a 1 5/8".

3. Quite la bisagra. Usando una broca de 1/4", taladre el orificio superior en la pilastra.
4. Sujete la hoja de la charnela a la parte superior de la pilastra usando una tuerca cilíndrica y un tornillo de tope.

IMPORTANTE: NO apriete el tornillo unidireccional por completo.

5. Ponga la charnela a escuadra con la pilastra. Ubique el orificio inferior en la pilastra. Marque (o punce) el orificio.



6. Taladre el orificio usando una broca de 1/4".
7. Sujete la hoja de la charnela a la parte inferior de la pilastra usando una tuerca cilíndrica y un tornillo de tope.

IMPORTANTE: NO apriete por completo los tornillos unidireccionales en este momento. Aún NO taladre los orificios restantes.

B. Prepare la puerta

NOTA: Si se requiere tener holgura de puerta, use una cuña continua debajo de la hoja de la puerta.

8. Coloque la puerta en la abertura. Ajuste una tolerancia de 1/16" a 1/4" entre el borde de la charnela de la puerta y la pilastra. Si está reemplazando los pivotes, centre la charnela entre los recortes de pivote de la puerta.

NOTA: La hoja de la charnela debe superponer la puerta 1 1/2" a 1 5/8" para permitir una tolerancia de 1/16" a 3/8" en el lado del cerrojo.

9. Ubique el orificio superior para la tuerca cilíndrica en la puerta. Marque (o punce) el orificio superior.
10. Retire la puerta de la abertura y colóquela en posición horizontal. Use una broca de 1/4" para taladrar el orificio.

C. Fije la puerta a la charnela

11. Sujete la hoja de la puerta de la charnela a la parte superior de la puerta usando una tuerca cilíndrica y un tornillo de tope.

IMPORTANTE: NO apriete por completo el tornillo unidireccional en este momento.

12. Ponga a escuadra la puerta respecto a la abertura. Luego ubique el orificio inferior para la hoja de la charnela de la puerta. Marque (o punce) el orificio.

13. Taladre el orificio usando una broca de barra de 1/4".
14. Sujete la hoja de la puerta de la charnela a la parte inferior de la puerta usando una tuerca cilíndrica y un tornillo de tope. La puerta debe estar centrada en la abertura y estar a escuadra con la pilastra.

IMPORTANTE: NO apriete por completo los tornillos unidireccionales en este momento.

15. Verifique que la puerta y la charnela estén a escuadra y funcionen adecuadamente. Use una broca de 1/4" para taladrar los orificios restantes, a través de la charnela, en la pilastra y la puerta.
16. Instale las tuercas cilíndricas y los tornillos de tope restantes. Revise el funcionamiento de la puerta. Si la puerta funciona adecuadamente, apriete bien todos los tornillos.

D. Instale las cubiertas de la hoja

17. Alinee la cubierta de la hoja con el extremo superior de la charnela.
18. Comenzando desde la parte superior y trabajando hacia abajo, aplique presión a la cubierta de la hoja para encajarla en su lugar (Fig. 2).

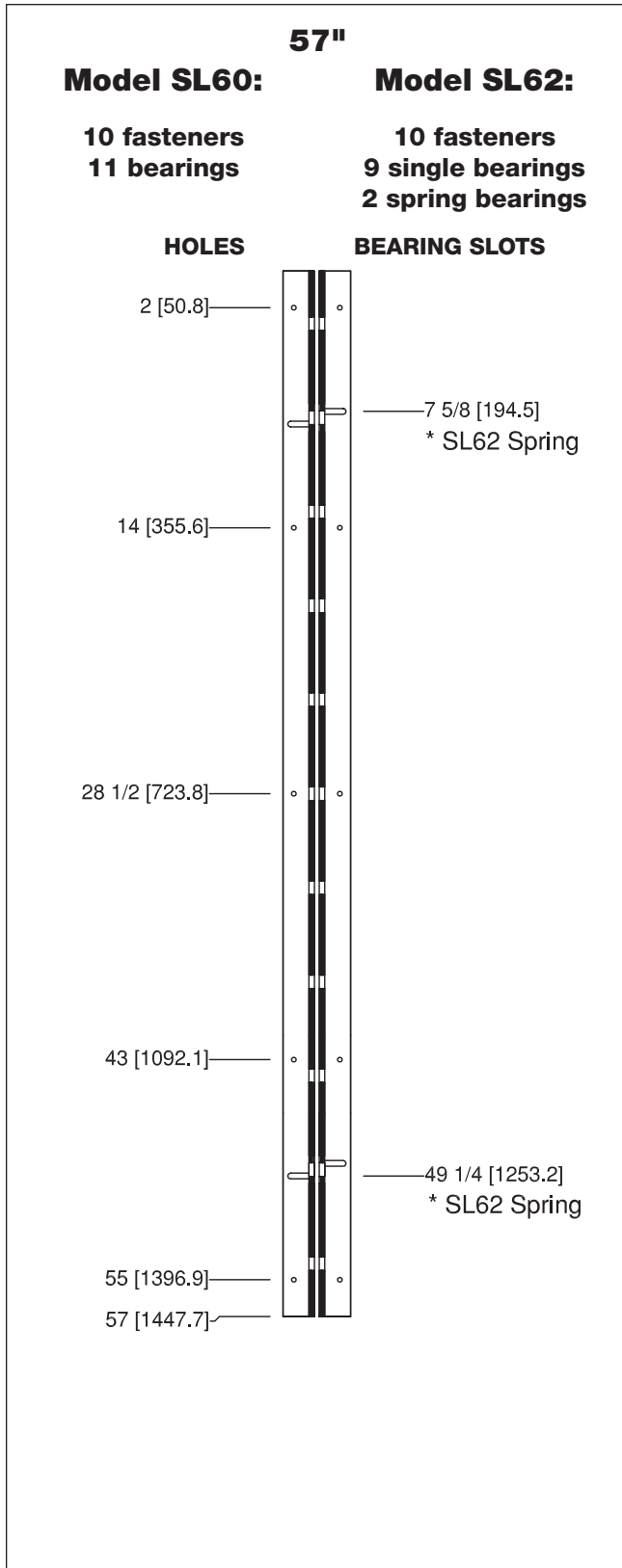
NOTA: Si usa un martillo para colocar la cubierta en su lugar, dé pequeños golpes asegurándose de proteger de daños la superficie de la cubierta.

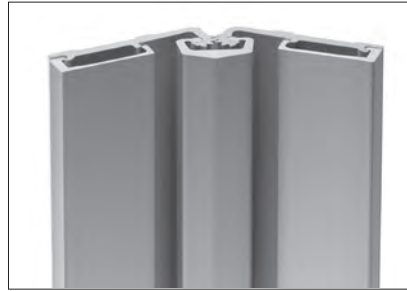
19. Apriete los tornillos de ajuste con una llave Allen de 5/64".

NOTA: La puerta y las cubiertas de la pilastra pueden quitarse y volverse a instalar.

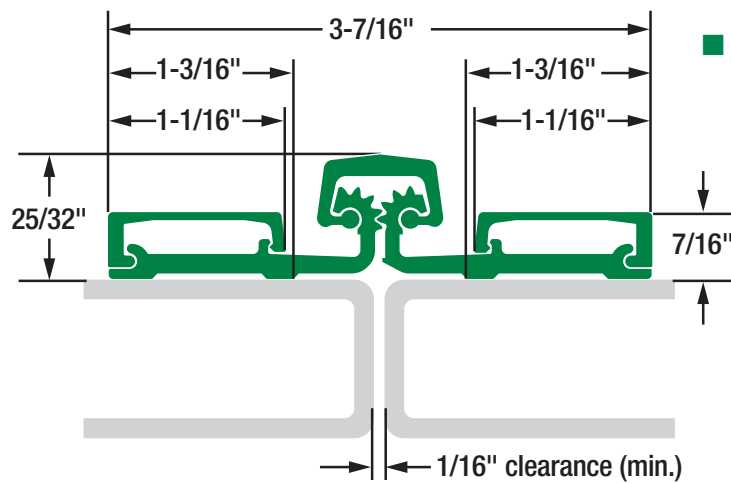
Toilet Partition Geared Hinges

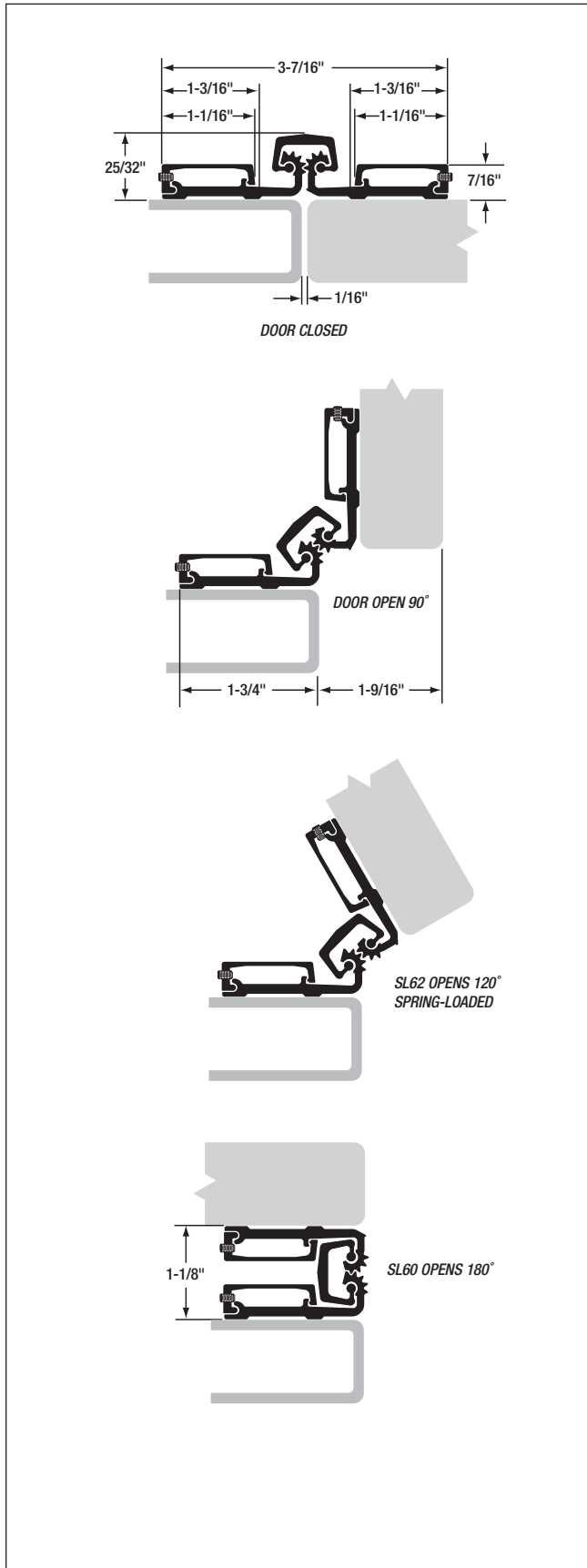
- All dimensions are measured in inches and [millimeters] from the top of the door to the centerline of the holes.
- Minimum hinge length for two spring bearings on SL62 = 43-1/2".





- Anodized aluminum
- SL60 opens 180°
- SL62 opens 120°, spring loaded
- One-way fasteners available for 3/4", 1" and 1-1/4" partitions
- For doors weighing up to 80 lb.
- 36" maximum door width





MATERIAL: Extruded 6063 T6 aluminum alloy with self-lubricating polyester thrust bearings.

LENGTH: 57" length standard for nominal door heights. Custom lengths are available. SL62: 43-1/2" min.

LOAD/FREQUENCY: For high-frequency partition doors 36" wide (max.) weighing up to 80 pounds without frame or door reinforcement.

FINISHES: All SL60 and SL62 hinges are stocked in Clear anodized aluminum. Custom anodized or painted finishes are available. Product painted or anodized in the field voids the SELECT hinge warranty.

ORDER: Specify SL60 or SL62. Also specify fasteners, which are for 3/4", 1" and 1-1/4" partitions. The SL60 and SL62 are supplied with one-way, slotted, chrome-finished 10-24 fasteners and a 5/64" hex key to install the door leaf and pilaster leaf covers.

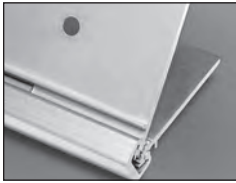


BHMA CERTIFICATION: SL60

SL60/SL62 HINGE SCREW COUNT

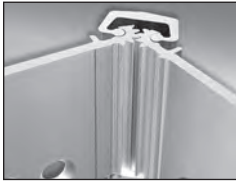
HINGE LENGTH	DOOR SCREWS	FRAME SCREWS
57"	5	5

SELECT ADVANTAGES



PAIR-MATCHED™ HINGE LEAVES

Manufactured together, machined together and anodized together, making SELECT hinges fit your doors better and last longer.
An exclusive SELECT benefit.



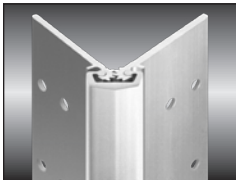
LIFETIME LUBRICATION

Eliminates the need for periodic maintenance. Quiet performance. Fights gear cap wear.
An exclusive SELECT benefit.



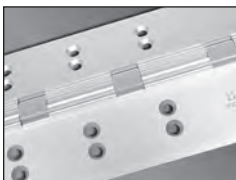
ANODIZED AFTER MACHINING

Delivers superior wear, durability and life. Inhibits corrosion. Few hinge makers follow SELECT's lead in using this superior manufacturing process.



SUSTAINABLE

Made from up to 100% recycled aluminum. Reduces environmental impact and qualifies for LEED points.
An exclusive SELECT benefit.



CONSISTENT TEMPLATING

Hole pattern is identical on both Heavy Duty 300 and Heavy Duty 600 models, so SELECT hinges line up precisely for easier and faster installation.
An exclusive SELECT benefit.



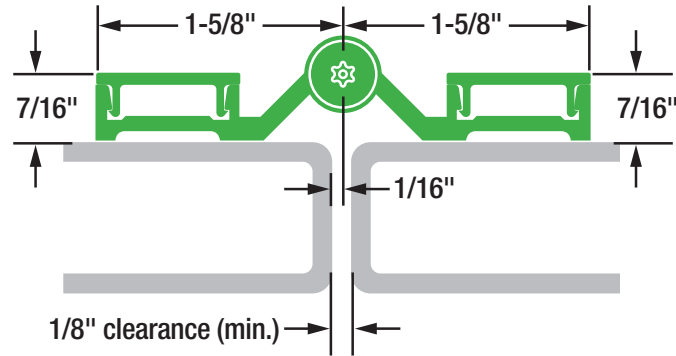
CUSTOM COLORS

Match any paint color on the gear cap or the entire hinge and fasteners, including our always-in-stock Bone White gear caps. Anodized colors also available.

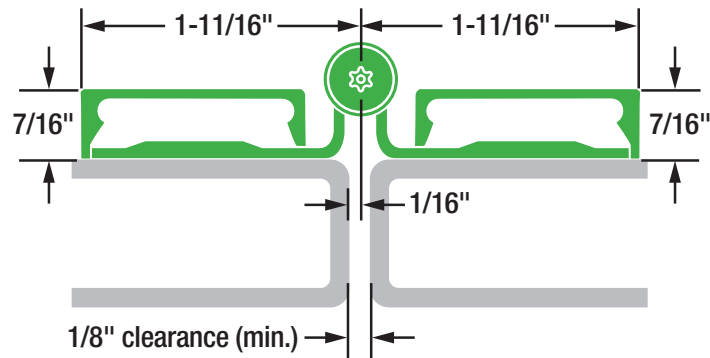
SELECT HINGE PERFORMANCE

- A SELECT geared continuous hinge has been tested in accordance with ANSI 250.4-1994 test procedure and acceptance criteria for physical endurance for steel doors and hardware and has surpassed 25,000,000 cycles during testing by an independent laboratory. On a door cycling 400,000 times per year, a SELECT hinge will be performing for over 62 years.
- SELECT geared continuous hinges are built to handle abuse from high-traffic applications. They are applied to the surface on the edge of the frame and door. No machining or reinforcement is required.
- The revolutionary SELECT geared continuous hinge puts an end to costly and irritating hinge failure problems, the most common cause of entrance failure.
- On conventional hinges, opening and “kick-back” energy concentrate on a few inches of fastened reinforcing plate — with the top hinge handling 100% of the force. Pinless SELECT hinges bond the door and frame into an integrated, sag-free unit. “Kick-back” energy dissipates along the entire length of the door and frame. (Compare this to a conventional hinge’s 4-1/2" to 5" at the top of the door and frame).
- SELECT geared continuous hinges eliminate the gap between the door and frame, providing a weatherproof, rust-proof, tamper-proof barrier. When the door is closed, there are no accessible screws, bolts or pins.

SL402TP



SL902TP



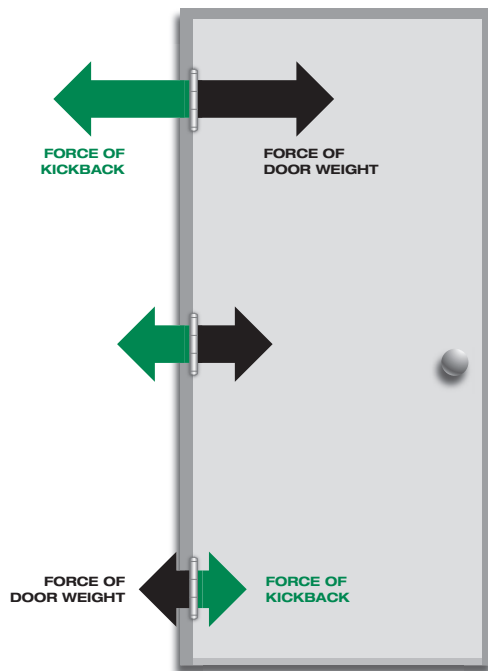
PIN & BARREL TOILET PARTITION HINGES

HINGE PART NUMBER INTERCHANGE: TOILET PARTITION HINGES

SELECT MODELS	MARKAR	HAGER	PEMKO	MCKINNEY	STANLEY	ABH	IVES
SL402	FS-402-TP						
SL902	FS-902-TP						

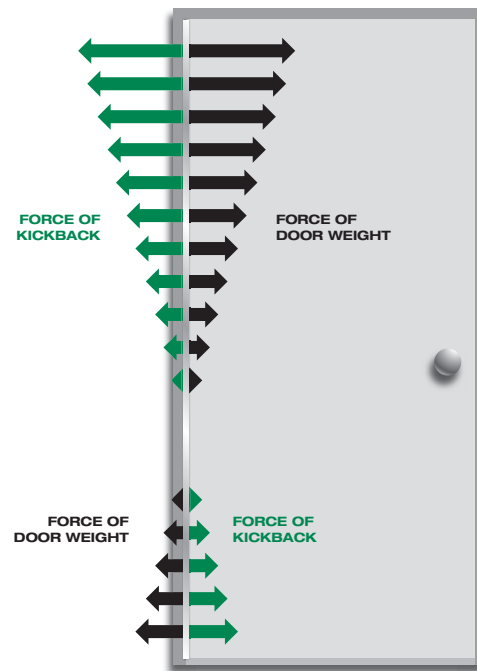
No equivalent hinge available from this manufacturer.

HINGE STRESS COMPARISON



CONVENTIONAL BUTT HINGES

On conventional hinges, opening and “kickback” energy from closers and automatic operators concentrates on the top butt hinge. This force works against the top hinge, eventually forcing it apart or pulling it from the frame/door.



CONTINUOUS HINGES

SELECT continuous hinges unite the door and frame into an integrated, sag-free unit. “Kickback” energy dissipates along the entire length of the door and frame and prevents hinge failure.

INSTALLATION INSTRUCTIONS

Toilet Partition Pin and Barrel Continuous Hinge

SL402



PRODUCT MUST BE INSTALLED ACCORDING TO ALL APPLICABLE BUILDING AND LIFE SAFETY CODES

All holes in door and frame must be drilled correctly and fasteners properly installed.

Important Warranty Information:

The following actions will void any warranty, expressed or implied:

- Failure to install the hinge according to the manufacturer's specifications and requirements. (for more information, visit selecthingerequirements.com)
- Use of fasteners other than those supplied with the hinge.
- Unauthorized field modifications, including alteration of the original finish or painting the hinge.

Do Not install Snap-On Cover until installation is 100% complete, and all aspects of the assembly are correctly fastened and properly fitted. The cover is impossible to remove without damage and replacement may be necessary.

Perform each step of the following instructions:

1. Door Preparation and Mounting

- Place the hinge on partition door as shown (Fig. 1). Be sure the hinge is properly aligned with the top of the door. Measure from the edge of the door to hinge at both the top and bottom to ensure that the hinge is located squarely on the door (Fig. 2).
- Mark the top and bottom holes on the door with a center punch. The use of a center punch can help center the hole so that the fasteners will enter straight. Drill the hole using a #14 (0.182") drill bit.
- Fasten the hinge to the door with 1/4" - 14 x 3/4" Torx Pan Head Screws.
- Install the three cover clips in each leaf by passing a screw through the clip and hinge leaf and into the door (Fig. 2). We recommend that the clips be positioned at the top, center and bottom holes.

2. Frame Preparation and Mounting

- Place the door and hinge assembly into the partition opening at the desired height from the finished floor. A small frame constructed of several blocks of wood can help support the door assembly.
- Place the hinge leaf onto the pilaster, center the door in the opening and repeat steps (1B) and (1C) above.
- Check the swing of the door to see if the clearance at the latch side is correct.
- Center punch the remaining holes, drill and fasten with the remaining Torx Pan Head Screws.
- When installation is complete, hold the Snap-On cover squarely on the leaf.
- Starting at the top and working downwards, press the cover in place until the entire length is firmly engaged.
Note that the hinge pin has been staked at one end with a roll pin on the back of the knuckle. All adjustments are made at the opposite end of the hinge.
- With the covers firmly in place, secure them at both ends through the hinge and into the door or frame with #8 x 3/4" Torx Flat Head Undercut Self-Drilling Screws.
- Use the Torx bit to turn the adjustment approximately one complete revolution. The hinge pin has a hole through it allowing adjustments to be made every half turn.
- Check the swing of the door. If the door will not close fast or hard enough, remove the 1/2" set pin and turn the adjusting screw one half turn. Reinsert the pin and check the swing of the door.
- Repeat steps (H) and (I) until the desired spring tension is reached. **DO NOT** over-tighten the spring, seven turns maximum.
- Hold the adjusting screw in place and tap the set pin in permanently with a hammer and nail set. Note that the knurled end of the set pin should lock into place. Approximately 1/8" to 1/16" of the set pin will stick out, allowing for readjustment of the hinge at a later date.

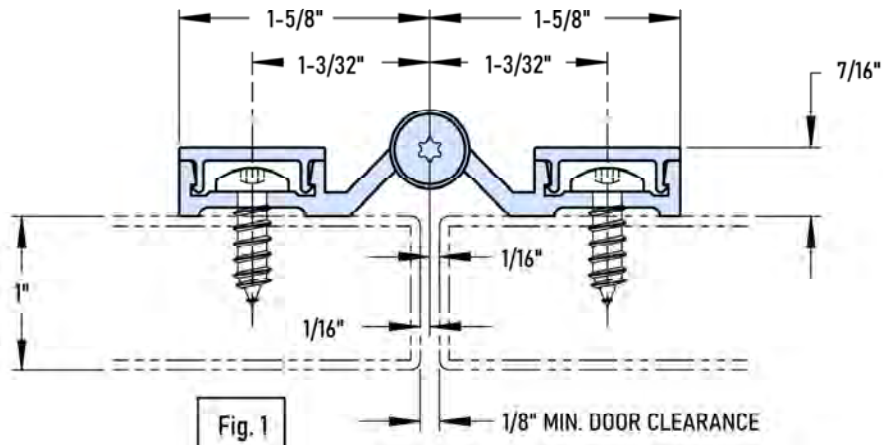


Fig. 1

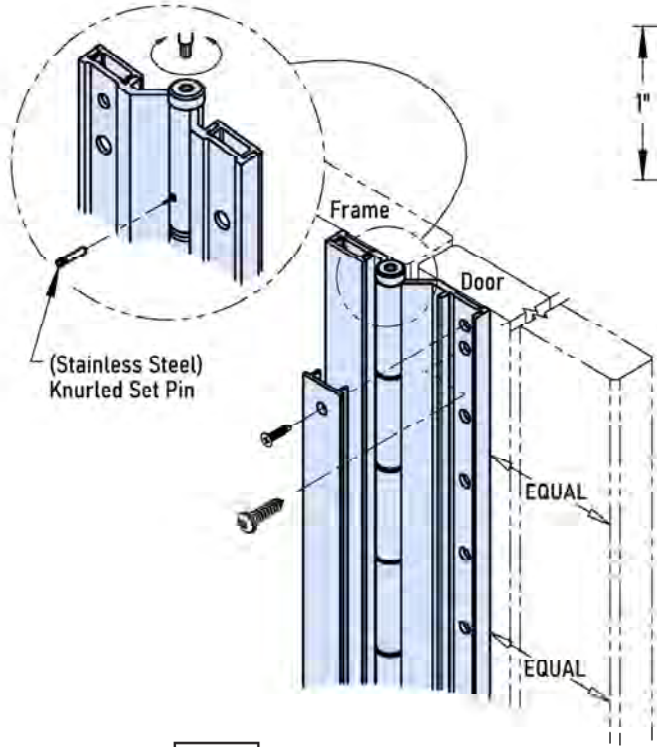


Fig. 2

STANDARD HARDWARE

1/4-14 X 3/4" TORX PAN HEAD SCREW (TKS14075R16)

#8 X 3/4" TORX FLAT HEAD UNDERCUT SELF-DRILLING SCREW (TKS8075Z)

3/32" X 1/2" STAINLESS KNURLED ROLL PIN (RLPN33250SS)

OPTIONAL HARDWARE AVAILABLE UPON REQUEST

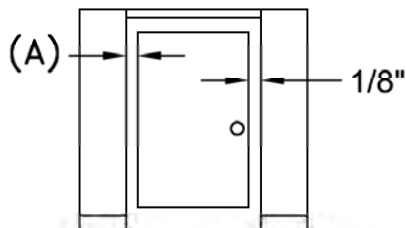
#12-8 X 1-1/2" FLAT HEAD UNDERCUT WOOD SCREW (PBS12150SP10SS)

Model SL402

Standard "Non-Adjustable" application clearances

Total Under-Sizing Required

Clearance (A)	Single Door
1/8"	5/16"



+ 1/16" Frame Irregularity



SELECT HINGES®

SELECT Products Limited

3258 Stadium Park Way

Kalamazoo, MI 49009

PH: 800-423-1174

Fax: 800-423-7107

www.select-hinges.com

INSTALLATION INSTRUCTIONS

Toilet Partition Pin and Barrel Continuous Hinge SL902



PRODUCT MUST BE INSTALLED ACCORDING TO ALL APPLICABLE BUILDING AND LIFE SAFETY CODES
All holes in door and frame must be drilled correctly and fasteners properly installed.

Important Warranty Information:

The following actions will void any warranty, expressed or implied:

- Failure to install the hinge according to the manufacturer's specifications and requirements.
(for more information, visit selecthingerequirements.com)
- Use of fasteners other than those supplied with the hinge.
- Unauthorized field modifications, including alteration of the original finish or painting the hinge.

Do Not install Snap-On Cover until installation is 100% complete, and all aspects of the assembly are correctly fastened and properly fitted. The cover is impossible to remove without damage and replacement may be necessary.

Perform each step of the following instructions:

1. Door Preparation and Mounting

- A. Place the hinge on partition door as shown (Fig. 1). Be sure the hinge is properly aligned with the top of the door. Measure from the edge of the door to hinge at both the top and bottom to ensure that the hinge is located squarely on the door (Fig. 2).
- B. Mark the top and bottom holes on the door with a center punch. The use of a center punch can help center the hole so that the fasteners will enter straight. Drill the hole using a #14 (0.182") drill bit.
- C. Fasten the hinge to the door with 1/4" - 14 x 3/4" Torx Pan Head Screws.
- D. Install the three cover clips in each leaf by passing a screw through the clip and hinge leaf and into the door (Fig. 2). We recommend that the clips be positioned at the top, center and bottom holes.

2. Frame Preparation and Mounting

- A. Place the door and hinge assembly into the partition opening at the desired height from the finished floor. A small frame constructed of several blocks of wood can help support the door assembly.
- B. Place the hinge leaf onto the pilaster, center the door in the opening and repeat steps (1B) and (1C) above.
- C. Check the swing of the door to see if the clearance at the latch side is correct.
- D. Center punch the remaining holes, drill and fasten with the remaining Torx Pan Head Screws.
- E. When installation is complete, hold the Snap-On cover squarely on the leaf.
- F. Install the Snap-On covers by engaging the side of the cover next to the hinge pin first.
- G. Insert a large screwdriver between the hinge knuckle and the cover. Using the screwdriver as a lever, twist it and snap the opposite side of the cover onto the clip.

Note that the hinge pin has been staked at one end with a roll pin on the back of the knuckle. All adjustments are made at the opposite end of the hinge.

- H. With the covers firmly in place, secure them at both ends through the hinge and into the door or frame with #8 x 3/4" Torx Flat Head Undercut Self-Drilling Screws.
- I. Use the Torx bit to turn the adjustment approximately one complete revolution. The hinge pin has a hole through it allowing adjustments to be made every half turn.
- J. Check the swing of the door. If the door will not close fast or hard enough, remove the 1/2" set pin and turn the adjusting screw one half turn. Reinsert the pin and check the swing of the door.
- K. Repeat steps (I) and (J) until the desired spring tension is reached. **DO NOT** over-tighten the spring, seven turns maximum.
- L. Hold the adjusting screw in place and tap the set pin in permanently with a hammer and nail set. Note that the knurled end of the set pin should lock into place. Approximately 1/8" to 1/16" of the set pin will stick out, allowing for readjustment of the hinge at a later date.

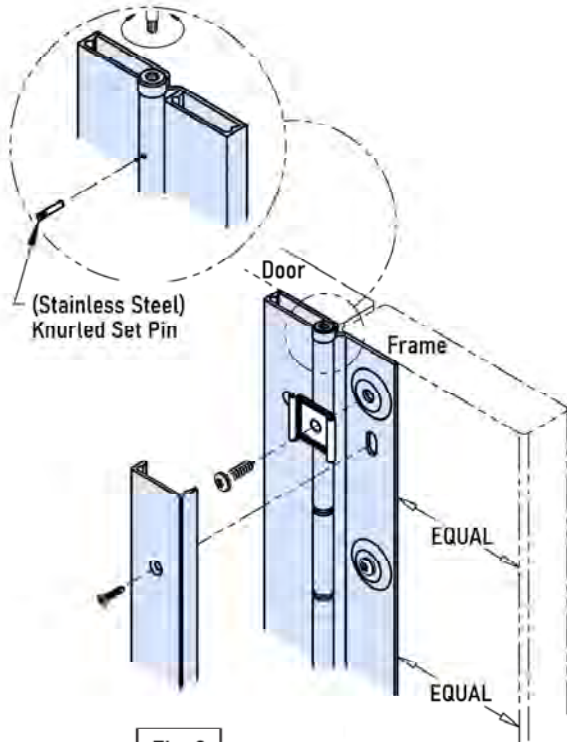


Fig. 2

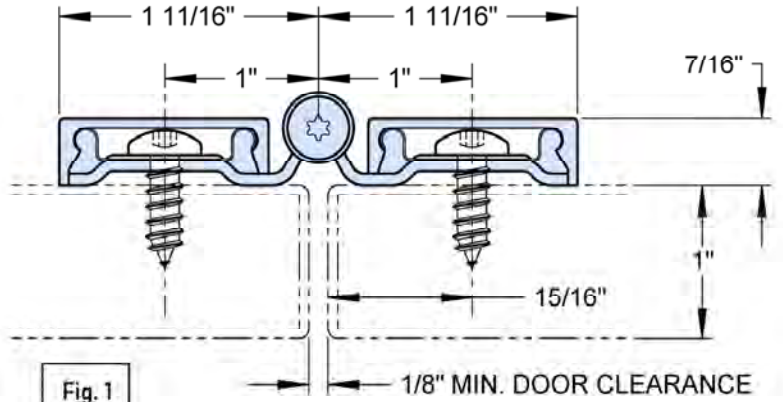


Fig. 1

STANDARD HARDWARE



1/4-14 X 3/4" TORX PAN HEAD SCREW
(TKS14075R16)



#8 X 3/4" TORX FLAT HEAD UNDERCUT
SELF-DRILLING SCREW (TKS8075Z)



3/32" x 1/2" STAINLESS KNURLED
ROLL PIN (RLPN33250SS)



COVER CLIP
(606 M22-0130-01)

OPTIONAL HARDWARE
AVAILABLE UPON REQUEST



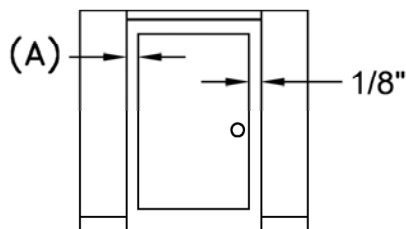
#12-8 x 1-1/2" FLAT HEAD UNDERCUT
WOOD SCREW (PBS12150SP10SS)

Model SL902

Standard "Non-Adjustable" application clearances

Total Under-Sizing
Required

Clearance (A)	Single Door
1/8"	5/16"



+ 1/16" Frame
Irregularity



**SELECT
HINGES**

SELECT Products Limited

3258 Stadium Park Way

Kalamazoo, MI 49009

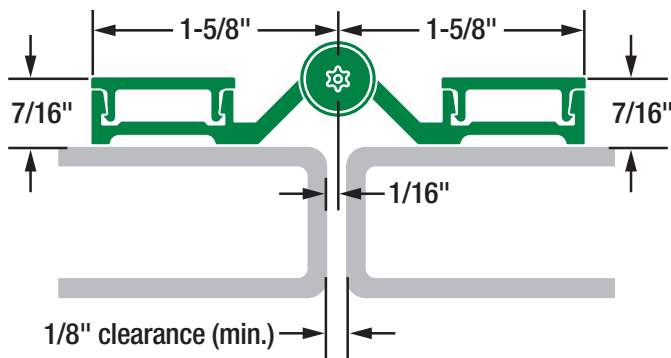
PH: 800-423-1174

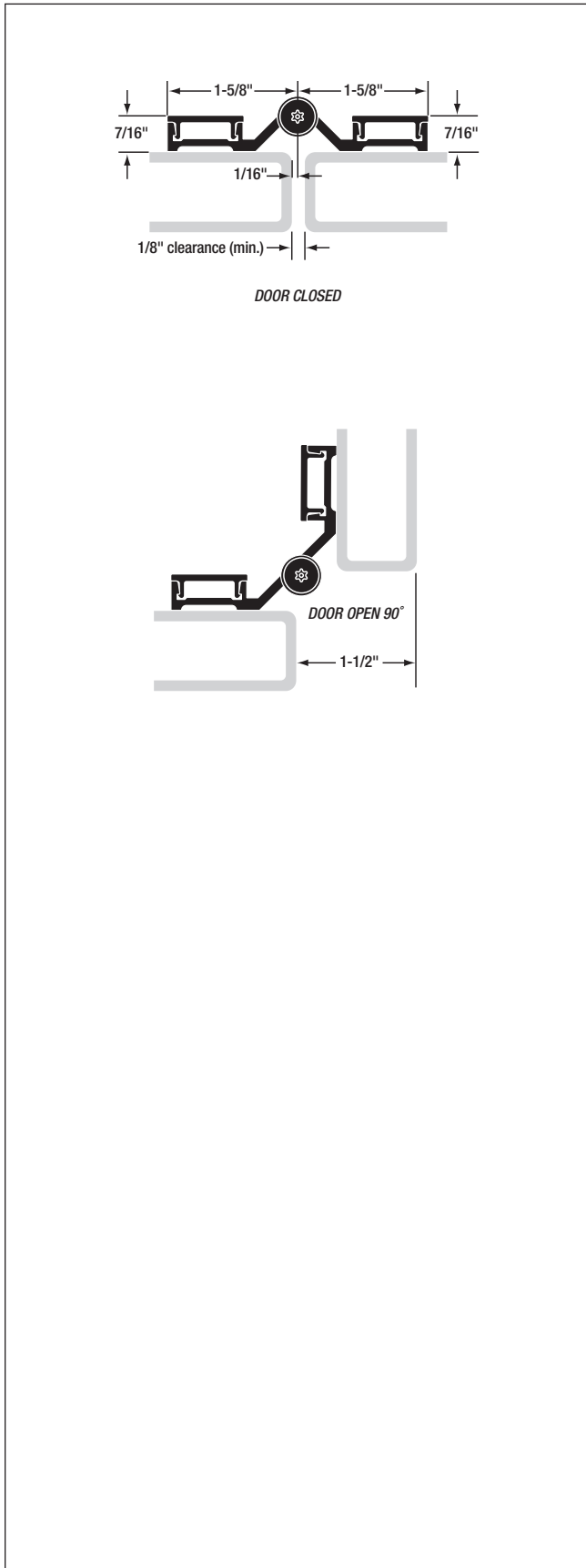
Fax: 800-423-7107

www.select-hinges.com



- Anodized aluminum
- Removable roll pin for spring-loaded adjustment
- Tamper-resistant Torx® head end caps to adjust spring tension
- For doors weighing up to 80 lb.
- Consult factory for doors wider than 36"





MATERIAL: 6463-T5 aluminum with 1/4" diameter 303 stainless steel self-closing pin assembly. Long-life split nylon bearings.

LENGTH: 54" length standard for nominal door heights. Special lengths available: 24" minimum, 72" maximum.

LOAD/FREQUENCY: For high-frequency partition doors 36" wide weighing up to 80 pounds without frame or door reinforcement. Consult factory for doors wider than 36".

FINISH: Anodized aluminum.

ORDER: #14 x 3/4" Torx® button head sheet metal screws are provided as a standard pack.

SL402TP HINGE SCREW COUNT		
HINGE LENGTH	DOOR SCREWS	FRAME SCREWS
54"	6	6

SELECT ADVANTAGES



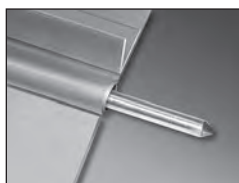
TEMPLATED HOLE PATTERN

SELECT hinges line up perfectly, precisely, every time. Makes installation easier and faster.



NYLON DOUBLE BEARINGS

Create a strong, free-moving assembly that allows closers and other door hardware to function properly.



STAINLESS STEEL PIN

Delivers high tensile strength by forming a strong, free-moving unit. Flexible and strong in abused openings.

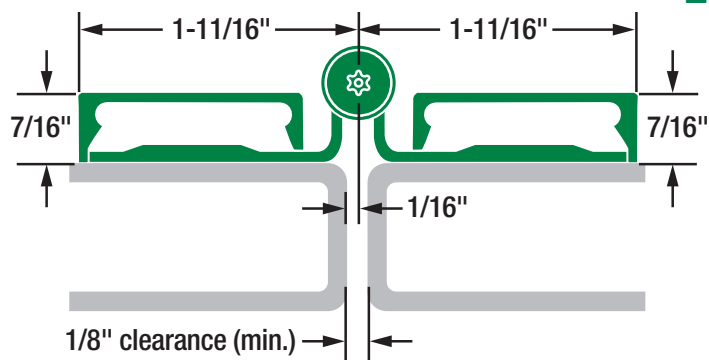


**SELECT
HINGES™**

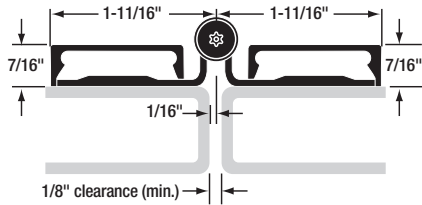
SL902TP Toilet Partition Pin & Barrel Continuous Hinge



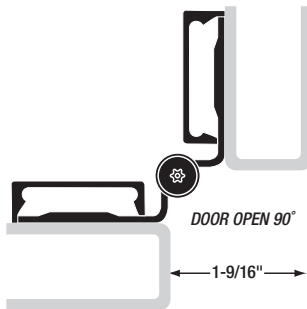
- Stainless steel
- Removable roll pin for spring-loaded adjustment
- Tamper-resistant Torx® head end caps to adjust spring tension
- For doors weighing up to 80 lb.
- Consult factory for doors wider than 36"



SL902TP



DOOR CLOSED



DOOR OPEN 90°

MATERIAL: 14 gauge stainless steel with 1/4" diameter 303 stainless steel self-closing pin assembly. Long-life split nylon bearings.

LENGTHS: 54" and 57" lengths standard for nominal door heights. Special lengths available: 24" minimum, 72" maximum.

LOAD/FREQUENCY: For high-frequency partition doors 36" wide weighing up to 80 pounds without frame or door reinforcement. Consult factory for doors wider than 36".

FINISH: US32D Satin Stainless Steel (630).

ORDER: Specify hinge length. 1/4-20 x 3/4" panhead self-drilling screws are provided as a standard pack.

SL902TP HINGE SCREW COUNT

HINGE LENGTH	DOOR SCREWS	FRAME SCREWS
54"	6	6
57"	6	6

SELECT ADVANTAGES



**CORROSION-RESISTANT
STAINLESS STEEL**

Stainless steel pin & barrel design creates a tough, highly secure opening.



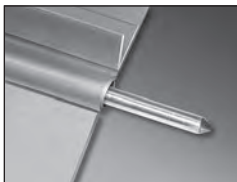
TEMPLATED HOLE PATTERN

SELECT hinges line up perfectly, precisely, every time. Makes installation easier and faster.



NYLON DOUBLE BEARINGS

Create a strong, free-moving assembly that allows closers and other door hardware to function properly.



STAINLESS STEEL PIN

Delivers high tensile strength by forming a strong, free-moving unit. Flexible and strong in abused openings.



END CAPS

Spiral-knurled steel caps seal the barrel ends to contain hinge pin.

Security Latch Guard

SECURITY LATCH GUARD



SECURITY LATCH GUARD

Outswing Latch Guard Installation Instructions – LGO



Important Warranty Information:

The following actions will void any warranty, express or implied

- Failure to install the Latch Guard properly, with supplied fasteners
- Unauthorized field modifications, including alteration of the original finish or painting

NOTE Latch Guard can be trimmed around frame and door hardware, but Latch Guard must remain as a single piece and sit flat on face of frame and door – do NOT cut into sections, See trim example (Fig. 1).

Also, some modifications may be necessary for deeper door insets.

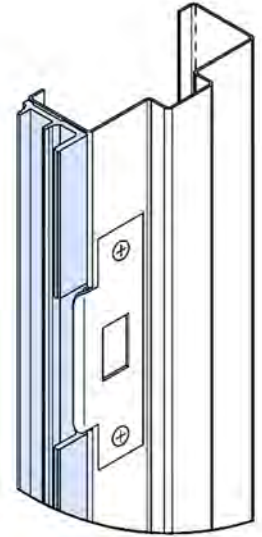


Fig. 1

1: Frame Preparation

- Place male portion of Latch Guard on face of frame as shown (Fig. 2) using the correct vertical spacing, and while making sure that this piece is flush with the frame and not overhanging far enough to interfere with the door, fasten firmly in place using the supplied self-drilling panhead hardware in the six holes provided. You may also mark the fastener holes in the frame first with a pencil or punch if desired.
- Drill additional holes near the middle of the Latch Guard and attach using the last of the self-drilling fasteners provided, making sure to space the holes equally and concentrate near the strike location. (6 holes have been provided, we suggest a minimum of 8, spacing additional holes evenly around existing hardware for frame AND door.)

2: Door Preparation

- With the door closed, center the female door portion of the Latch Guard over the male. To help with centering, it is recommended to place the pink foam material, supplied as part of packaging material, over the male portion near top and bottom. Press the female section over the male, wedging the foam material between both parts to hold the door section in position for mounting, making sure to also center this section vertically and NOT get the foam trapped between the Latch Guard and door. (Fig. 3)
- Using the six pre-drilled holes in the Latch Guard, drill the six $3/8"$ diameter holes through the door. You may also mark the hole locations on the door, remove the female Latch Guard and drill the six $3/8"$ diameter holes through the door with the female section of the Latch Guard removed if preferred and reinstall.
- With the door open and foam removed, push the barrel nuts through the extrusion and door at each hole location and tighten each of the shoulder bolts from the other side of the door. Close the door and check fit and function. Now drill the final three holes and install the remaining barrel nuts and shoulder bolts.
- Starting at the top of the Latch guard, and using a plastic mallet or hammer and a block of wood, press the frame cover on firmly, working from top to bottom (Fig. 4)

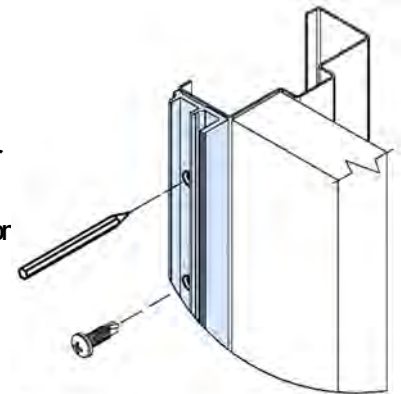


Fig. 2

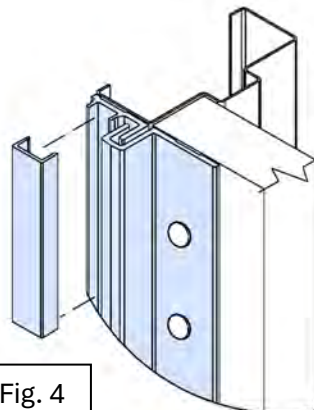
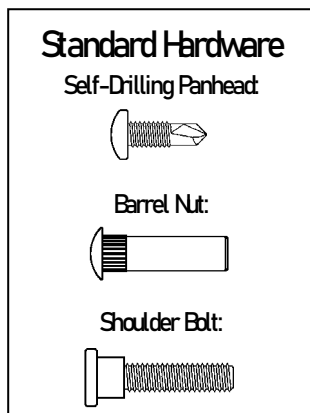


Fig. 4

Pink foam (included)

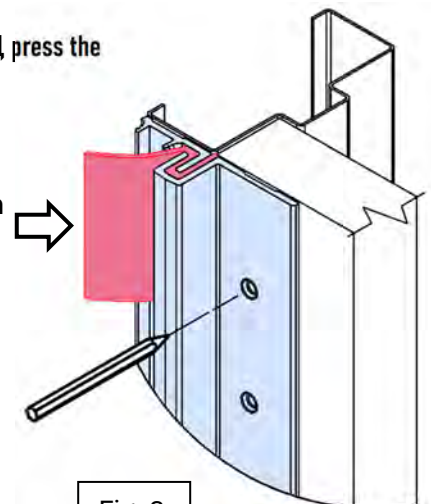
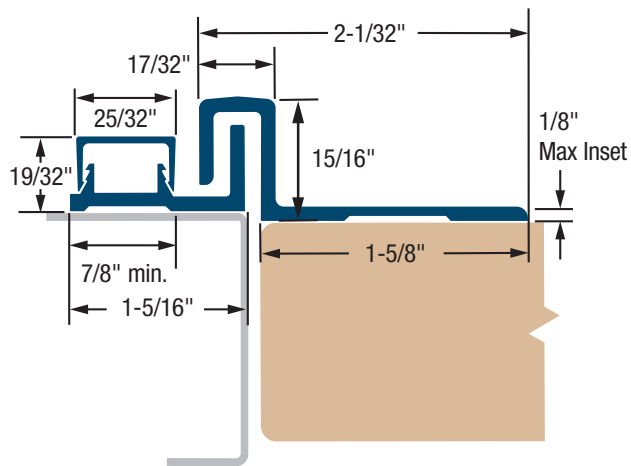
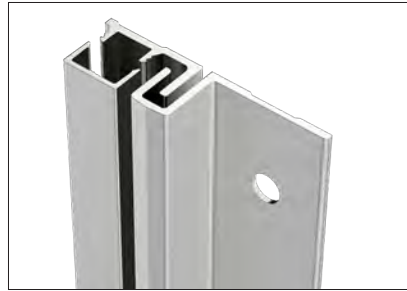
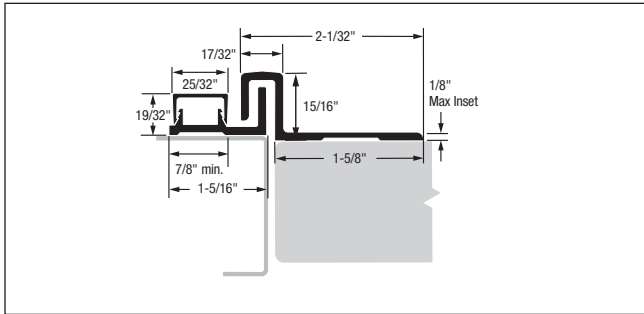


Fig. 3



- Pre-drilled holes and included fasteners save valuable time
- Fasteners concealed on jamb side for added security
- Robust appearance scares off break-in attempts
- Full-length protection deters air wedges, pry bars, Sawzalls and loiding
- Blends seamlessly with a SELECT continuous geared hinge
- Outswing
- 83" and 95" lengths
- Clear, Dark Bronze and Black anodized aluminum



MATERIAL: Extruded 6063 T6 aluminum alloy.

LENGTHS: 83" and 95" lengths standard for nominal door heights.

FINISHES: All Latch Guards are stocked in Clear, Dark Bronze and Black anodized aluminum.

ORDER: Specify outswing latch guard (LGO), length and finish. 12-24 x 3/4" self-drilling, thread-forming 410SS Phillips panhead screws, 1/4-20 through-bolts and 1/4-20 shoulder screws (for doors up to 1-3/4" thick) are provided as a standard pack unless otherwise specified. Long barrel nuts available for 2" – 2-1/4" doors. Security shoulder screws optional at extra cost.

LATCH GUARD SCREW COUNT

HINGE LENGTH	DOOR SCREWS	FRAME SCREWS
83"	9	9
95"	9	9

SPECIFICATIONS

Security Latch Guard



SELECT ADVANTAGES



ANODIZED AFTER MACHINING

Delivers superior wear, durability and life. Inhibits corrosion. Few hinge makers follow SELECT's lead in using this superior manufacturing process.



SUSTAINABLE

Made from recycled aluminum. Reduces environmental impact and qualifies for LEED points. *An exclusive SELECT benefit.*



ELECTRIC PREPS & ACCESSORIES

ELECTRIC PREPS & ACCESSORIES

ELECTRIC PREPS & ACCESSORIES



ELECTRIC PREPS & ACCESSORIES



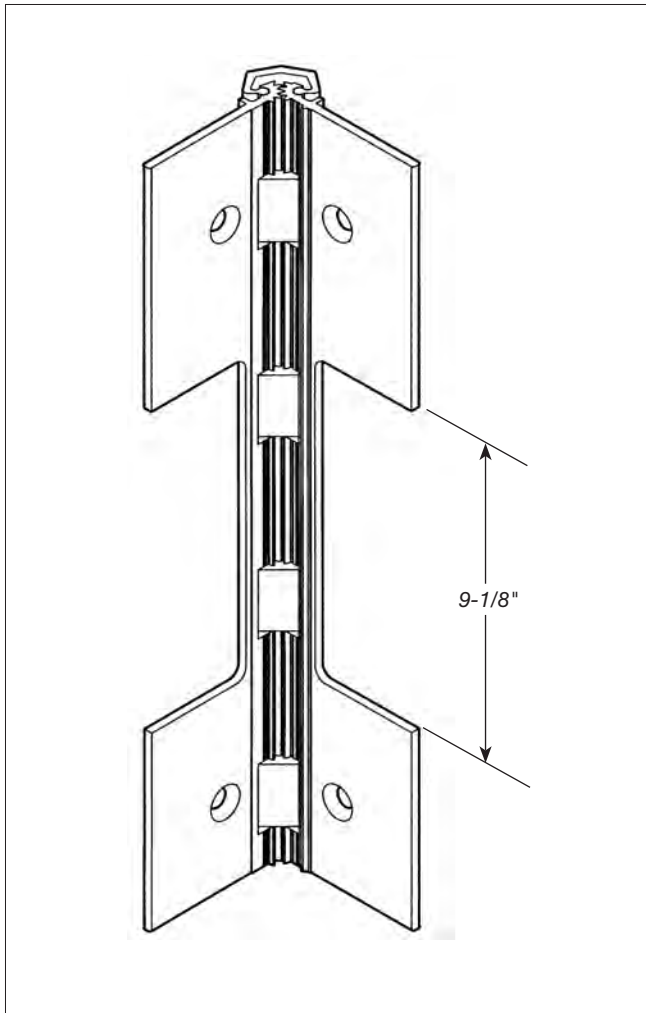
ELECTRIC PREPS & ACCESSORIES for Geared Continuous Hinges

ELECTRIC PREPS & ACCESSORIES: GEARED

ELECTRIC PREP MODIFICATIONS for Geared Continuous Hinges



ELECTRIC PREPS & ACCESSORIES: GEARED


**Cutout for Von Duprin EPT2,
EPT10, PN1, CEPT, ABH PT 200
or ABH PT 1000**

PREP: SELECT geared continuous hinges can be prepared for the Von Duprin EPT2 and EPT10 power transfer unit and the Von Duprin PNT1 pneumatic transfer unit; others available upon request (please see template on following page). Contact factory for quotes and availability on preparations for power transfer units.

LOCATION: Specify the dimension from the top of the hinge to the centerline of the cutout. (Cutout length is 9-1/8"; centerline of the cutout is 4-9/16" from the top edge of cutout.) Hinge is installed flush with the top of the door.

Refer to the templates in the Concealed or Half Surface Geared Hinge sections to avoid specifying a cutout location that cuts through fastener holes. These templates are also available online at www.selecthinges.com.

HANDING: Specify the handing of each door requiring the EPT. Handing not required on SL11 and SL27.

ORDER: Use suffix "VD-EPT" or "VD-PNT," plus the location and handing (if required).

Example: SL24 HD600 83" Clear VD-EPT 41" from top of hinge to centerline, RH.

AVAILABILITY: Available on geared hinge models SL11, SL12, SL14, SL18, SL24, SL26, SL27, SL31, SL40, SL41, SL44, SL48, SL52, SL53, SL54, SL77 and SL84. For the SL40 and SL41, please consult factory for engineering approval.

LEAD TIME: 48 hours (on most orders).

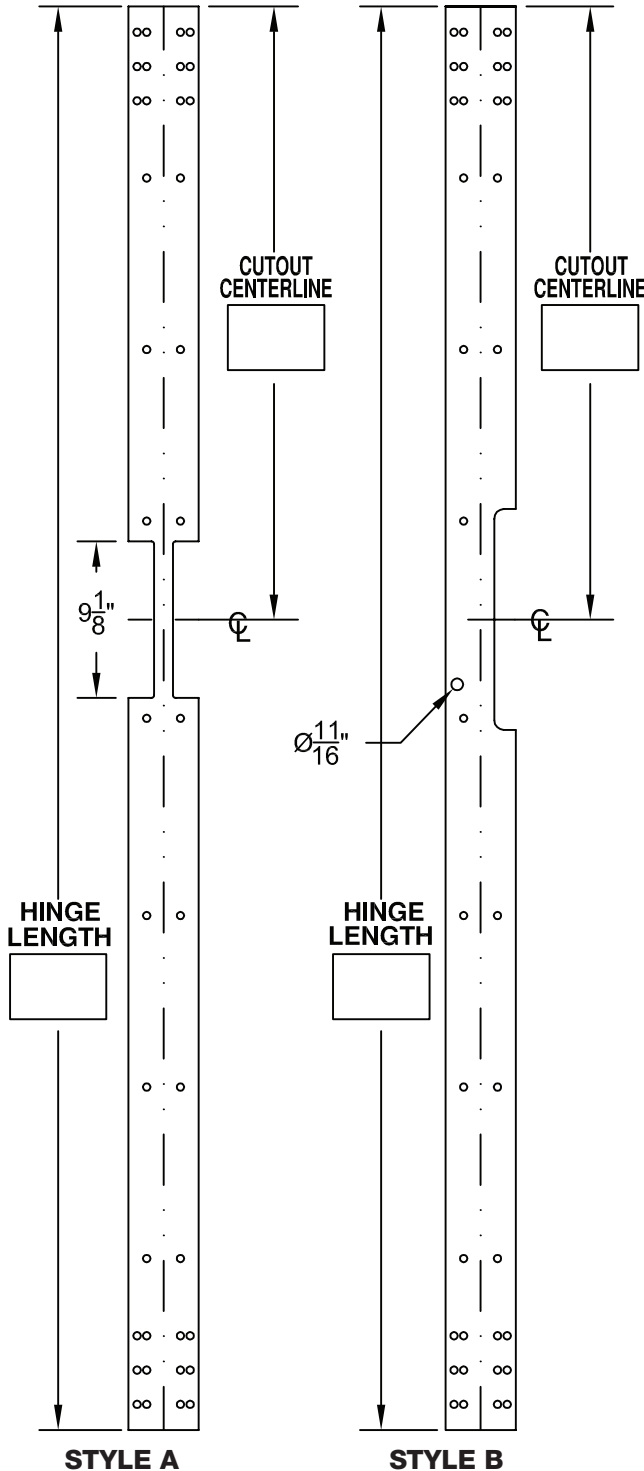
IMPORTANT: *SELECT Products Limited does not recommend preparing door and frame for EPT before receipt of hinge. If door and frame must be prepared before receipt of hinge, contact factory for special template.*

EPT/CPT Specification Template

FILL OUT AND RETURN THIS FORM TO:
 SELECT Products Limited 800-423-7107 customerservice@select-hinges.com

HINGE MODEL #: _____

SPECIFY DIMENSIONS IN BOXES:



POWER TRANSFER SELECTION:

- | STYLE A | STYLE B |
|--------------------------------------|---|
| <input type="checkbox"/> EPT 2 | <input type="checkbox"/> Adams Rite 4612-1 <input type="checkbox"/> PTR180 |
| <input type="checkbox"/> EPT10 | <input type="checkbox"/> Adams Rite 4612-2 <input type="checkbox"/> SDC PT-5 |
| <input type="checkbox"/> PNTI | <input type="checkbox"/> Dorma ES105 <input type="checkbox"/> Securitron EPT |
| <input type="checkbox"/> CEPT | <input type="checkbox"/> Precision EPT-5 <input type="checkbox"/> Securitron EPTL |
| <input type="checkbox"/> ABH PT 200 | <input type="checkbox"/> PT105 <input type="checkbox"/> Yale EPT |
| <input type="checkbox"/> ABH PT 1000 | <input type="checkbox"/> PT180 <input type="checkbox"/> Yale EPTL |
| | <input type="checkbox"/> PTR105 |

CUTOUT SHAPE: (MATCH EPT MOUNTING FLANGE)

- 

Round end




Square end


CUTOUT LOCATION:

- Door leaf Frame leaf


HANDING: (FROM KEYED SIDE)

- 


Right hand



Left hand



Right hand reverse



Left hand reverse

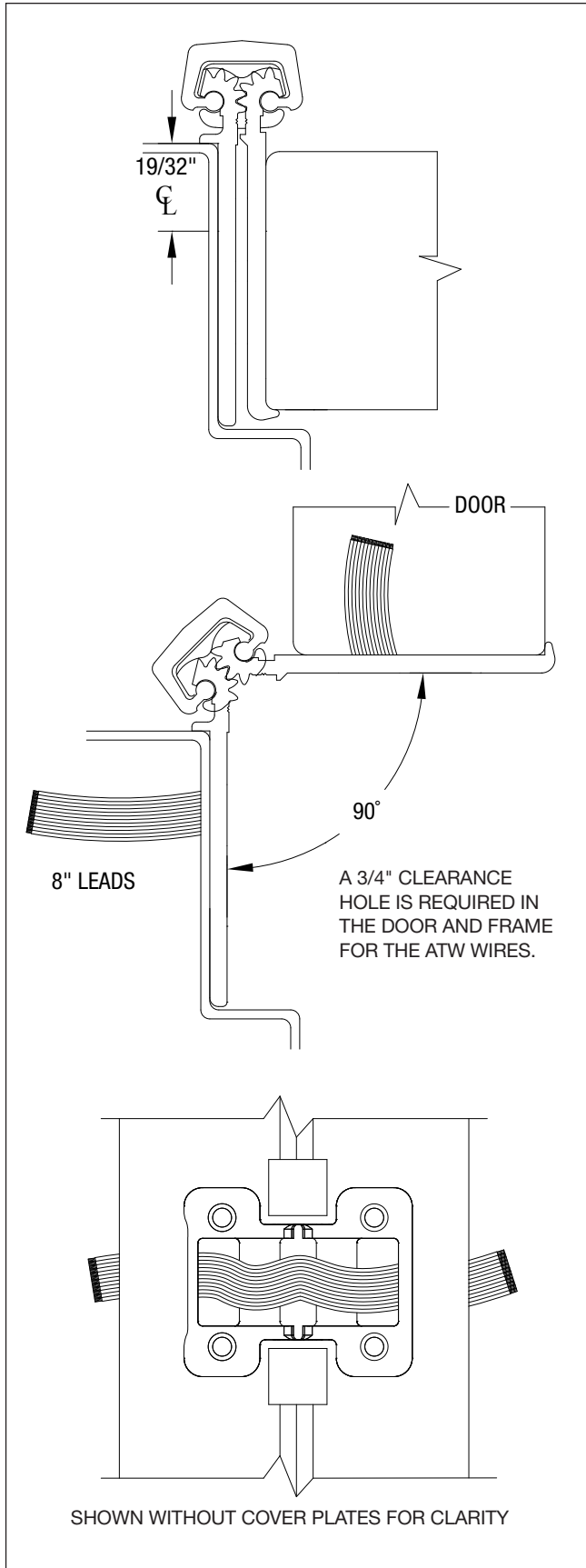
COMPANY: _____

APPROVED BY: _____

DATE: _____

P.O. NUMBER: _____

EPT/CPT
TEMPLATE



PREP: SELECT geared continuous hinges can be prepared for accessible electric through-wires to provide continuous current. Through-wires available in sets of 4, 8 or 12.

Per conductor: 12V-24V AC/DC at 3-6 amps. Ultra-flexible 22 gauge wire with 8" leads per leaf. Molex® connectors included. Connecting adaptors available as an option (see Electric Prep Accessories page).

LOCATION: Specify the dimension from the top of the hinge to each ATW centerline. Hinge is installed flush with the top of the door.

Refer to the templates in the Concealed Geared Hinge section to choose from available ATW locations. These templates are also available online at www.SelectHinges.com.

HANDING: Specify the handing of each door requiring the ATW. Handing not required on SL11 and SL27.

ORDER: Use suffix "ATW," plus the number of wires required. Specify location of each ATW and handing (if required).

Example: SL24 HD600 83" Clear ATW4 44-1/16" from top of hinge to centerline, RH.

NOTE: For 90-degree openings, please specify at time of order for no upcharge. There will be an upcharge for 90-degree ATW cover plates when ordered separately and clear or bronze must be specified.

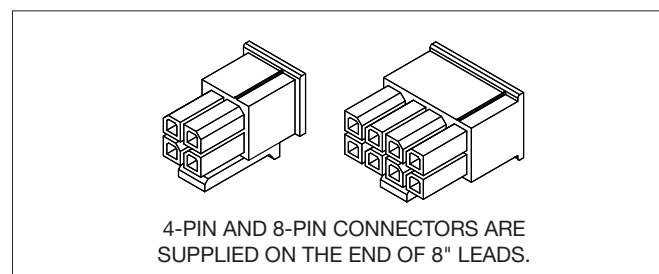
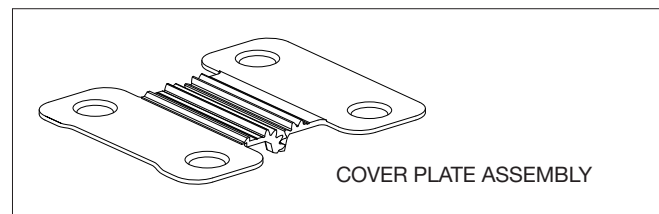
AVAILABILITY: Available on models SL11, SL12, SL14, SL18, SL24, SL26, SL27, SL31, SL44, SL48 and SL84.

Hinges with ATW prep can be ordered with a painted finish on the gear cap *only*.

LEAD TIME: 48 Hours (on most orders).

WARRANTY: 6 years.

IMPORTANT: SELECT Products Limited does not recommend preparing door and frame for ATW before receipt of hinge. If door and frame must be prepared before receipt of hinge, contact factory for special template.

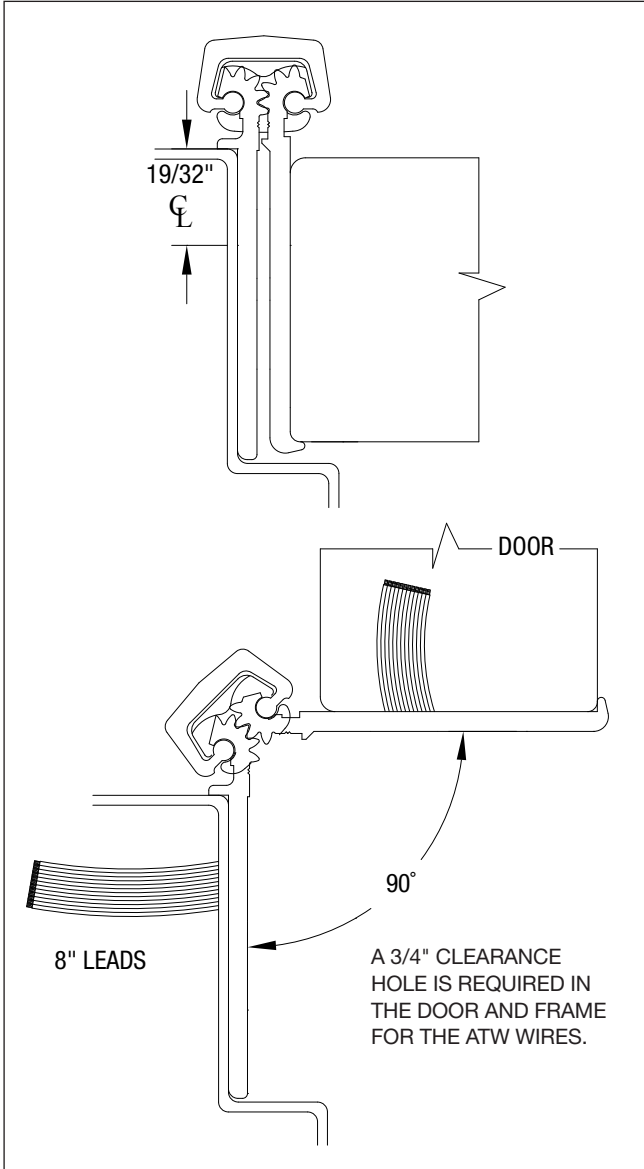


ATW PREP

ATWRP (4-1/4" ATW Removeable Panel)



ATWRP PANEL



PREP: 4-1/4 inch panel as a retrofit option to electrify an existing concealed hinge or fix a failed electronic entryway. Through-wires available in sets of 4, 8 or 12.

Per conductor: 12V-24V AC/DC at 3-6 amps. Ultra-flexible 22 gauge wire with 8" leads per leaf. Molex® connectors included. Connecting adaptors available as an option (see Electric Prep Accessories page).

ORDER: Indicate "ATWRP," plus the number of wires required. Specify hinge model for which the panel is needed, and Clear (CL), Dark Bronze (BR) or Black (BK) finish.

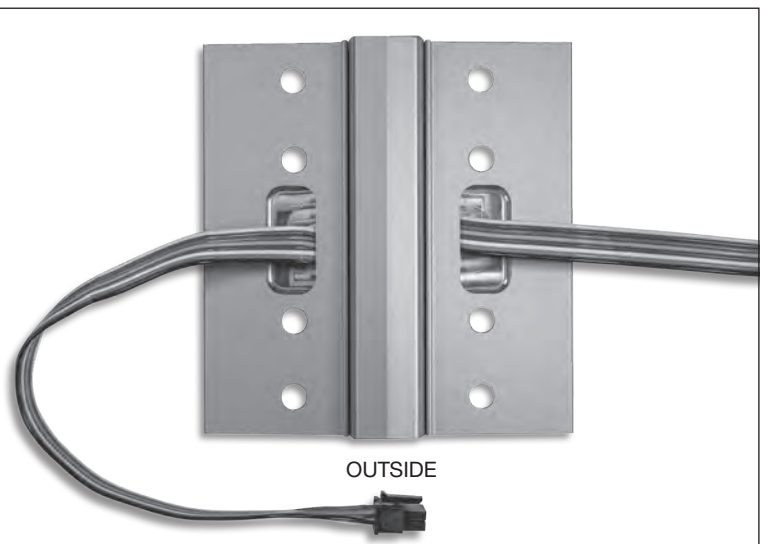
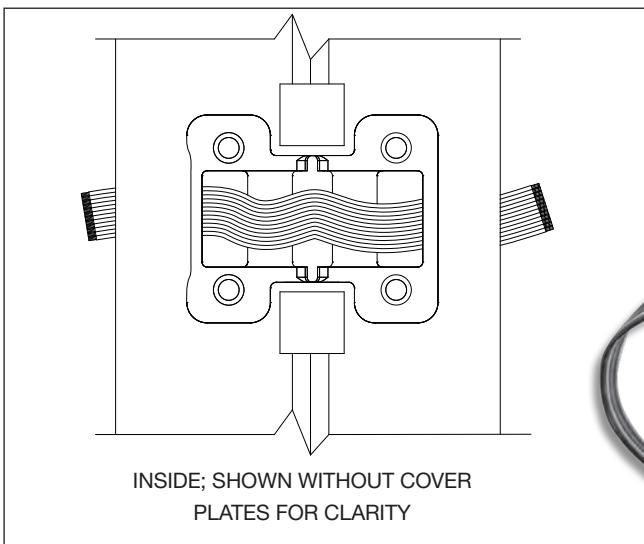
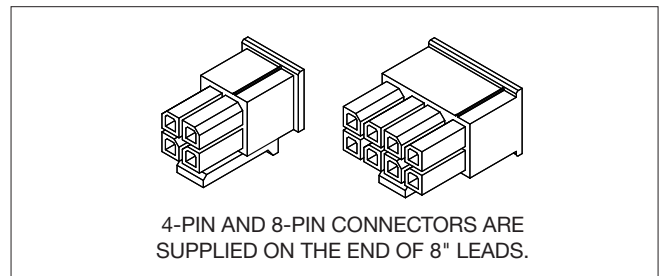
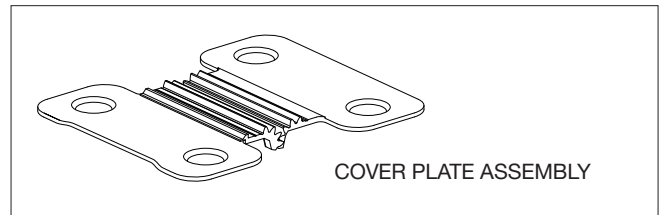
Example: ATWRP8 for SL24 CL.

AVAILABILITY: Available for models SL11, SL12, SL14, SL18, SL24, SL26, SL27, SL31, SL44, SL48 and SL84.

LEAD TIME: 48 Hours (on most orders).

WARRANTY: The ATWRP has no warranty.

IMPORTANT: SELECT Products Limited does not recommend preparing door and frame for ATWRP before receipt of hinge. If door and frame must be prepared before receipt of hinge, contact factory for special template.





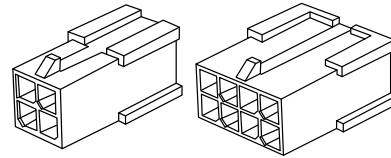
PREP: SELECT ATW lead adaptors with 12-wire Molex® connectors are available in 4 lengths: 8", 24", 48" and 120".

ORDER: Indicate "ATWADPT," plus the length required (8", 24", 48" or 120").

Example: ATWADPT8.

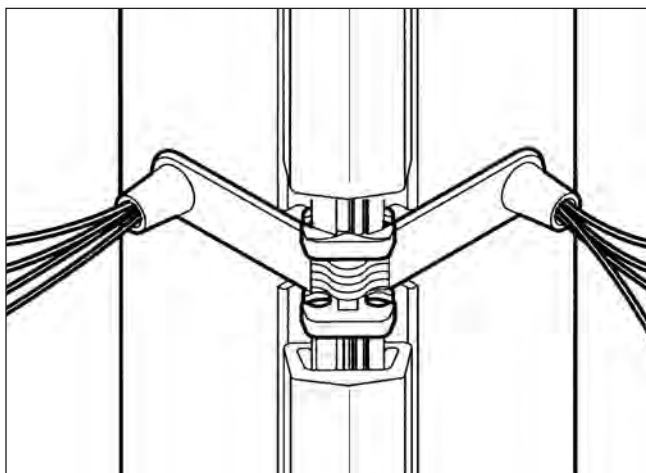
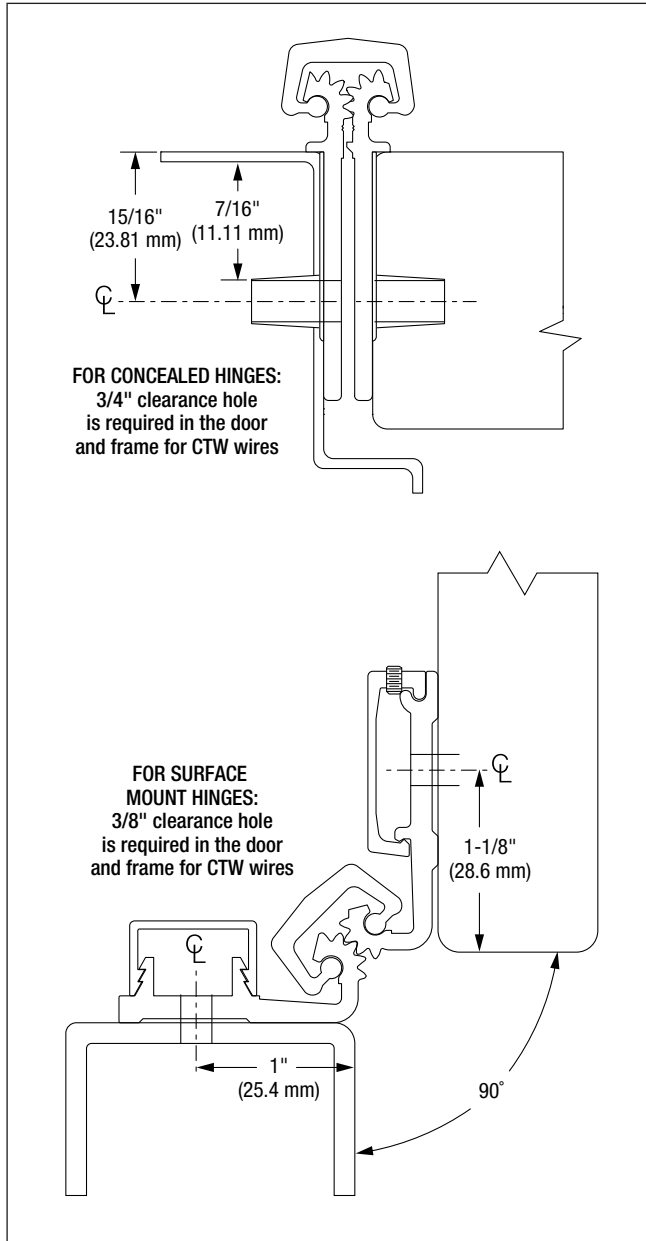
LEAD TIME: 48 Hours (on most orders).

WARRANTY: The ATWADPT has no warranty.



4-PIN AND 8-PIN CONNECTORS ARE SUPPLIED ON THE END OF 8" LEADS.

CTW (Concealed Through-Wire)



PREP: SELECT geared continuous hinges can be prepared for concealed electric through-wires to provide continuous current. Through-wires available in sets of 4, 5, 8, 10 or 12.

Per conductor: 12V-24V AC/DC at 3-6 amps. Ultra-flexible 22 gauge wire with 8" leads per leaf. Extra-long leads (48" max.) available.

NOTE: CTW4 and CTW5 preps require the replacement of one hinge bearing with a special bearing containing wires; CTW8 and CTW10 preps require the replacement of two bearings; CTW12 prep requires the replacement of three bearings.

LOCATION: Specify the dimension from the top of the hinge to each CTW bearing centerline. Hinge is installed flush with the top of the door.

Refer to the templates in the Concealed or Full Surface Geared Hinge sections to choose from available CTW bearing locations. These templates are also available online at www.SelectHinges.com.

HANDING: Specify the handing of each door requiring the CTW. Handing not required on SL11 and SL27.

ORDER: Use suffix "CTW," plus the number of wires required. Specify location of each CTW bearing and handing (if required).

Example: SL24 HD600 83" Clear CTW4 42-25/32" from top of hinge to centerline, RH.

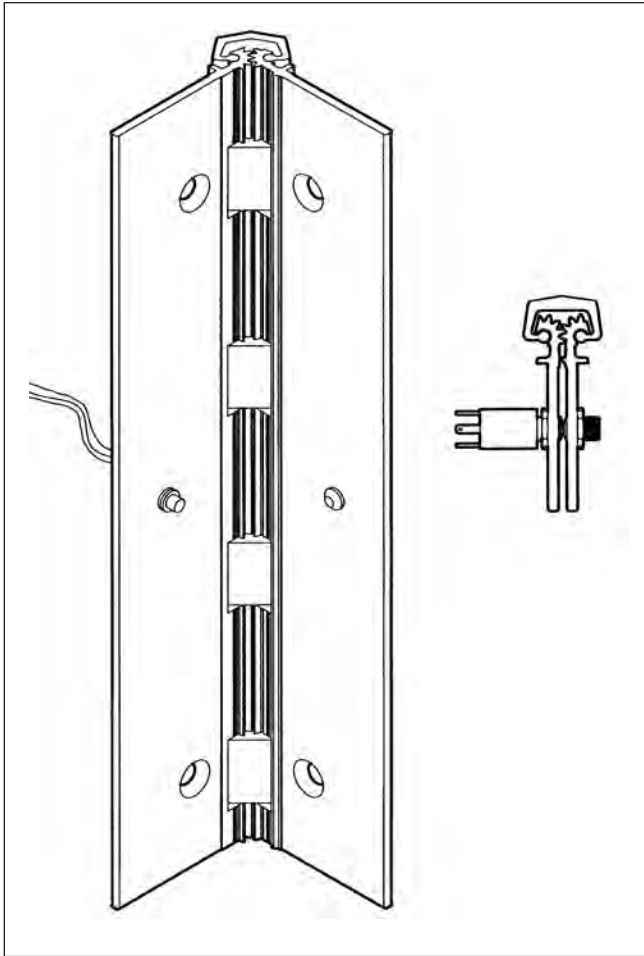
AVAILABILITY: All CTW options available on heavy duty (HD600 and LL) models SL11, SL12, SL14, SL18, SL24, SL26, SL27, SL31, SL44, SL48 and SL84, and heavy duty (HD600) model SL57. Heavy duty (HD300) models SL11, SL14, SL18, SL24 and SL57 available with 4- or 5-wire CTW only.

LEAD TIME: 48 Hours (on most orders).

WARRANTY: 5 years on electrical modification components.

IMPORTANT: SELECT Products Limited does not recommend preparing door and frame for CTW before receipt of hinge. If door and frame must be prepared before receipt of hinge, contact factory for special template.

CTW PREP

EMS (Exposed Electric Monitor Switch)


PREP: SELECT geared continuous hinges can be prepared for an exposed electric monitor switch to provide non-continuous current. 120V AC at 250MA 30W maximum.

LOCATION: Specify the dimension from the top of the hinge to the centerline of the EMS. Avoid putting the EMS within one inch of a fastener hole. Hinge is installed flush with the top of the door.

Refer to the templates in the Concealed Geared Hinge section to choose appropriate EMS location. These templates are also available online at www.SelectHinges.com.

HANDING: Specify the handing of each door requiring the EMS.

ORDER: Use suffix "EMS," plus the location and handing. Only one EMS is required per monitoring hinge.

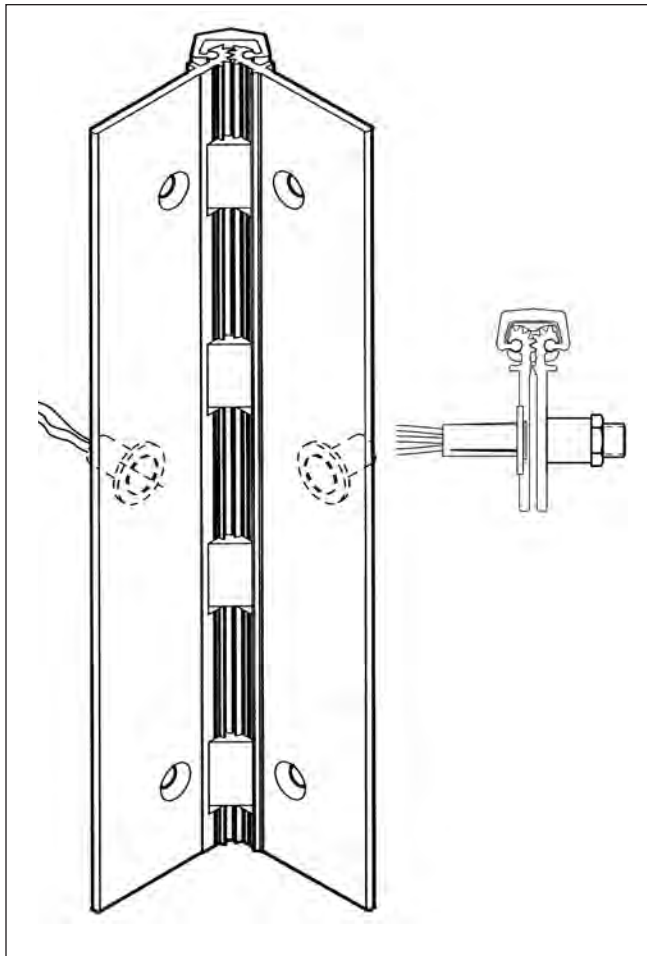
Example: SL24 HD600 83" Clear EMS 36" from top of hinge to centerline, RH.

AVAILABILITY: Available on geared hinge models SL11, SL12, SL14, SL18, SL24, SL26, SL27, SL31, SL38, SL40, SL41, SL44, SL48 and SL84.

LEAD TIME: 48 hours (on most orders).

WARRANTY: 5 years on electrical modification components.

IMPORTANT: SELECT Products Limited does not recommend preparing door and frame for EMS before receipt of hinge. If door and frame must be prepared before receipt of hinge, contact factory for special template.

CMG (Concealed Adjustable Monitor Switch)

PREP: SELECT geared continuous hinges can be prepared for a concealed adjustable magnetic monitor switch to provide non-continuous current. 22 gauge wire with 14" leads. 28V DC.

LOCATION: Specify the dimension from the top of the hinge to the centerline of the CMG. Avoid putting the CMG within one inch of a fastener hole. Hinge is installed flush with the top of the door.

Refer to the templates in the Concealed Geared Hinge section to choose appropriate CMG location. These templates are also available online at www.SelectHinges.com.

HANDING: Specify the handing of each door requiring the CMG.

ORDER: Use suffix "CMG," plus the location and handing. Only one CMG is required per monitoring hinge.

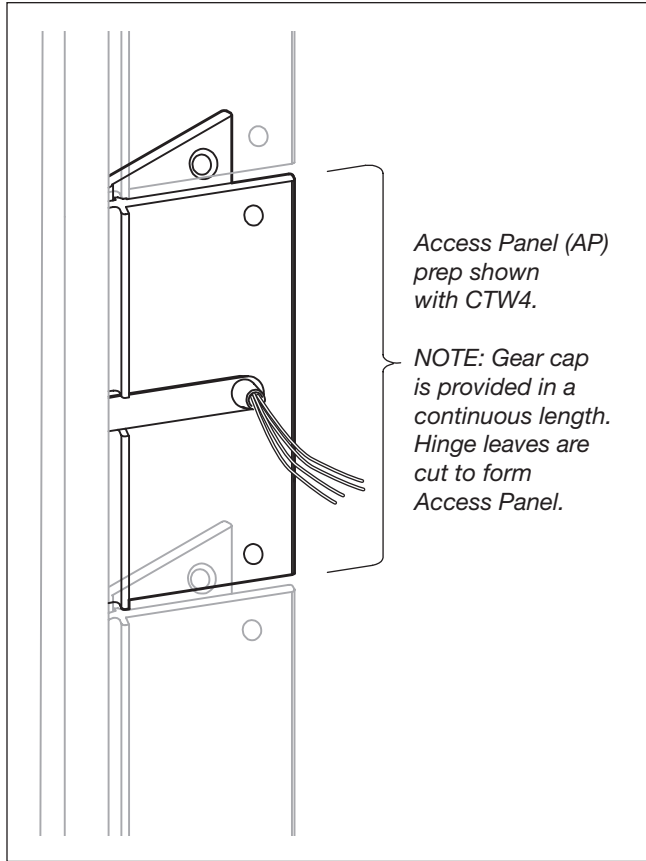
Example: SL24 HD600 83" Clear CMG 36" from top of hinge to centerline, RH.

AVAILABILITY: Available on geared hinge models SL11, SL12, SL14, SL18, SL24, SL26, SL27, SL31, SL40, SL41, SL44, SL48 and SL84.

LEAD TIME: 48 hours (on most orders).

WARRANTY: 5 years on electrical modification components.

IMPORTANT: *SELECT Products Limited does not recommend preparing door and frame for CMG before receipt of hinge. If door and frame must be prepared before receipt of hinge, contact factory for special template.*



PREP: SELECT geared continuous hinges can be prepared with hinge leaf panels to allow easy access to electrical components while preserving gear cap's appearance.

LOCATION: Dimensions will differ depending on the hinge model and electrical components requested. Hinges are installed flush with the top of the door.

A template requiring customer's approval will be designed by a SELECT engineer based on the customer's order.

HANDING: Specify the handing of each door requiring the AP.

ORDER: Use suffix "AP" after designating chosen electrical prep and its location(s). Specify handing.

Example: SL24 HD600 83" Clear CTW4 42-25/32" from top of hinge to centerline, AP, RH.

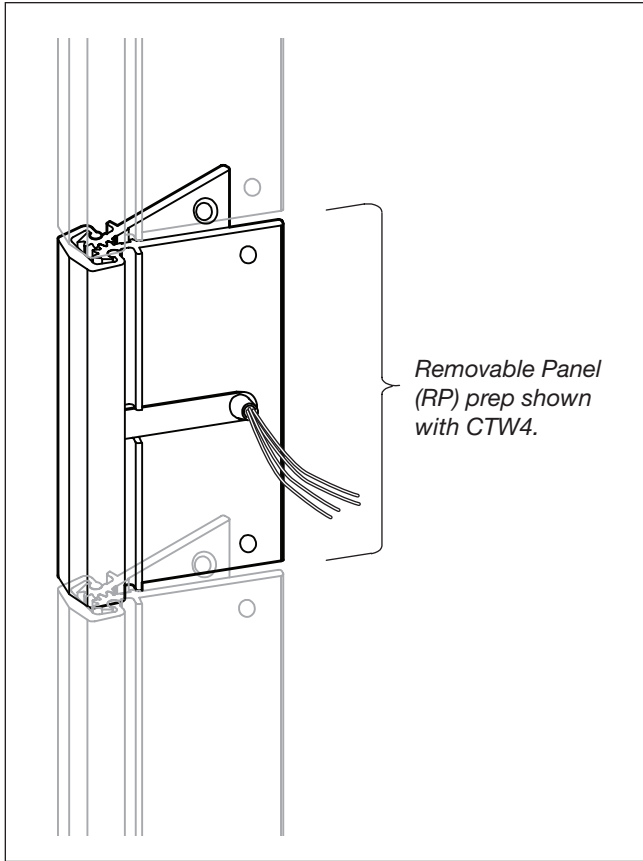
AVAILABILITY: Available on geared hinge models SL11, SL12, SL14, SL18, SL24, SL26, SL27, SL31, SL38, SL44, SL48.

LEAD TIME: 48 hours (on most orders).

WARRANTY: 2 years on electrical modification components.

IMPORTANT: *SELECT Products Limited does not recommend preparing door and frame for AP before receipt of hinge. If door and frame must be prepared before receipt of hinge, contact factory for special template.*

RP (Removable Panel)



PREP: SELECT geared continuous hinges can be prepared with removable hinge leaf panels to allow easy access and service of electrical components without removing the door.

LOCATION: Dimensions will differ depending on the hinge model and electrical components requested. Hinges are installed flush with the top of the door.

A template requiring customer's approval will be designed by a SELECT engineer based on the customer's order.

HANDING: Specify the handing of each door requiring the RP.

ORDER: Use suffix "RP" after designating chosen electrical prep and its location(s). Specify handing.

Example: SL24 HD600 83" Clear CTW4 42-25/32" from top of hinge to centerline, RP, RH.

AVAILABILITY: Available on geared hinge models SL11, SL12, SL14, SL18, SL24, SL26, SL27, SL31, SL38, SL44, SL48 and SL57.

LEAD TIME: 48 hours (on most orders).

WARRANTY: 2 years on electrical modification components.

IMPORTANT: *SELECT Products Limited does not recommend preparing door and frame for RP before receipt of hinge. If door and frame must be prepared before receipt of hinge, contact factory for special template.*



ELECTRIC PREP MODIFICATIONS

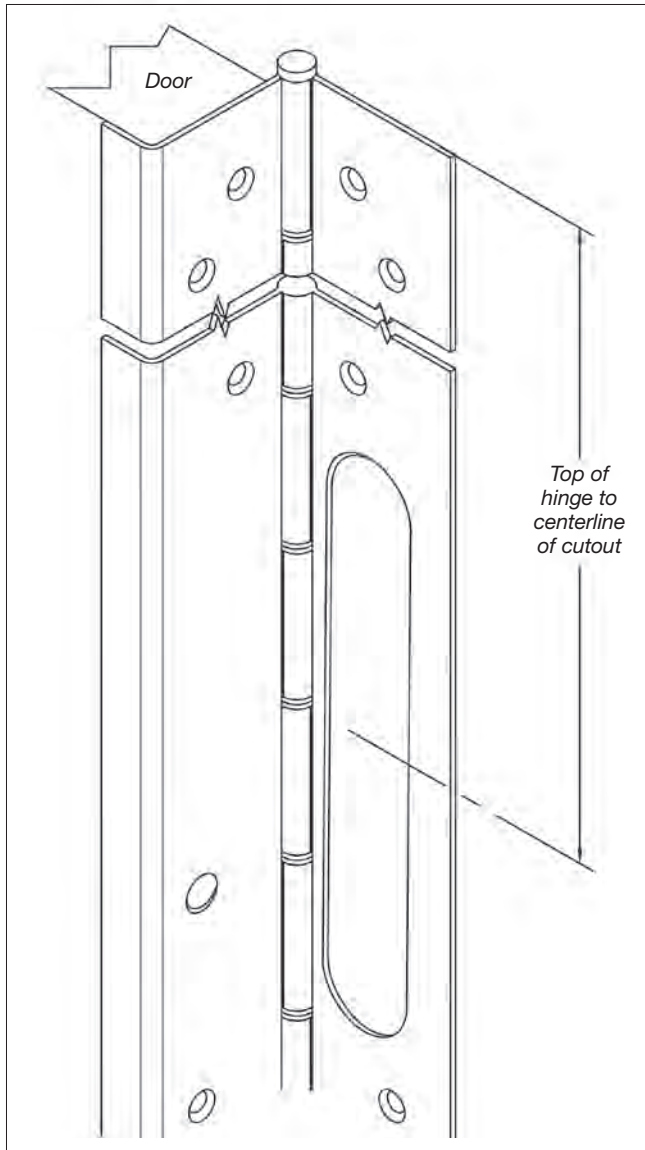
for Pin & Barrel Continuous Hinges

ELECTRIC PREPS & ACCESSORIES: PIN & BARREL

ELECTRIC PREP MODIFICATIONS
for Pin & Barrel Continuous Hinges



ELECTRIC PREPS & ACCESSORIES: PIN & BARREL



PREP: SELECT pin & barrel continuous hinges can be prepared for Adams Rite 4612 power transfer unit.

LOCATION: Standard locations from top of hinge to centerline of CTP-AR are as follows:

79" hinge = 39-3/8"

83" hinge = 41-9/16"

85" hinge = 42-1/2"

95" hinge = 47-1/2"

For custom locations, specify centerline dimension from top of hinge. Hinge is installed flush with the top of the door.

For CTP-AR prep on a Concealed Pin & Barrel hinge, refer to the templates in the Concealed Pin & Barrel Hinge section. For CTP-AR prep on a Half Surface or Half Mortise Pin & Barrel hinge, please consult the factory. The Concealed Pin & Barrel hinge templates are also available online at www.SelectHinges.com.

HANDING: Specify the handing of each door requiring the CTP-AR.

ORDER: Use suffix "CTP-AR," plus the location and handing.

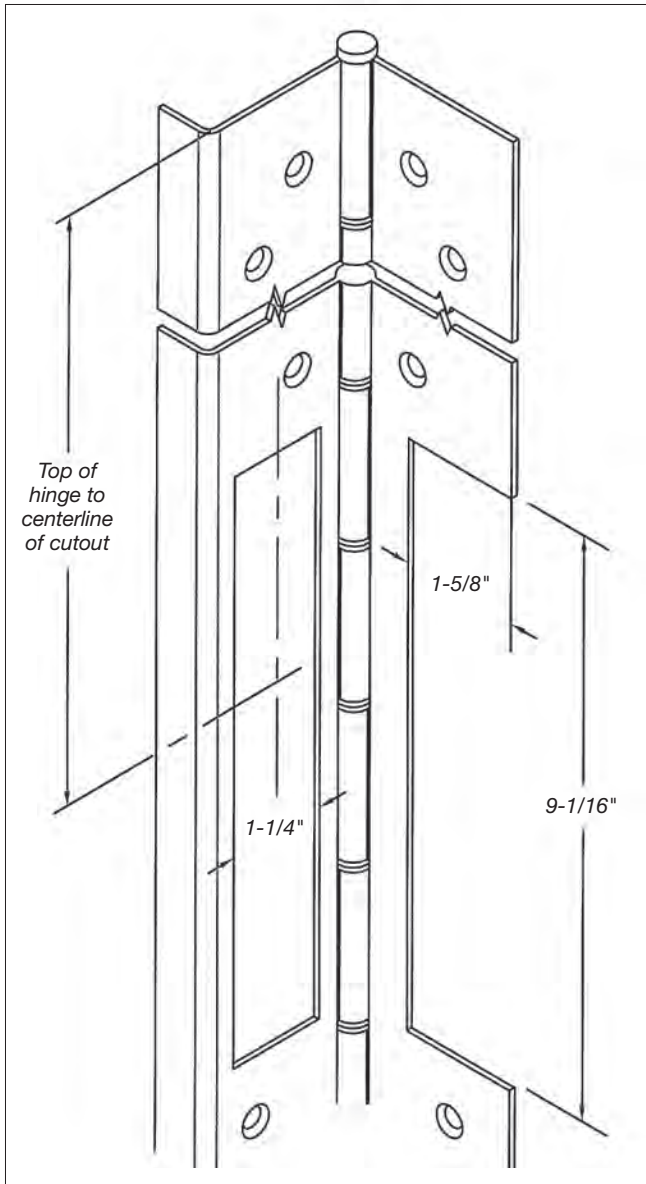
Example: SL300 83" SS, CTP-AR 39-3/8" from top of hinge to centerline, LH.

AVAILABILITY: Available on pin & barrel hinge models SL200, SL300, SL303, SL305, SL306, SL315 and SL3500.

LEAD TIME: Contact your SELECT representative.

WARRANTY: 5 years on electrical components.

IMPORTANT: SELECT Products Limited does not recommend preparing door and frame for CTP-AR before receipt of hinge. If door and frame must be prepared before receipt of hinge, contact factory for special template.



PREP: SELECT pin & barrel continuous hinges can be prepared for Von Duprin power transfer unit.

LOCATION: Standard locations from top of hinge to centerline of CTP-VD are as follows:

- 79" hinge = 39-3/8"
- 83" hinge = 41-9/16"
- 85" hinge = 42-1/2"
- 95" hinge = 47-1/2"

For custom locations, specify centerline dimension from top of hinge. Hinge is installed flush with the top of the door.

For CTP-VD prep on a Concealed Pin & Barrel hinge, refer to the templates in the Concealed Pin & Barrel Hinge section. For CTP-VD prep on a Half Surface or Half Mortise Pin & Barrel hinge, please consult the factory. The Concealed Pin & Barrel hinge templates are also available online at www.SelectHinges.com.

HANDING: Specify the handing of each door requiring the CTP-VD.

ORDER: Use suffix "CTP-VD," plus the location and handing.

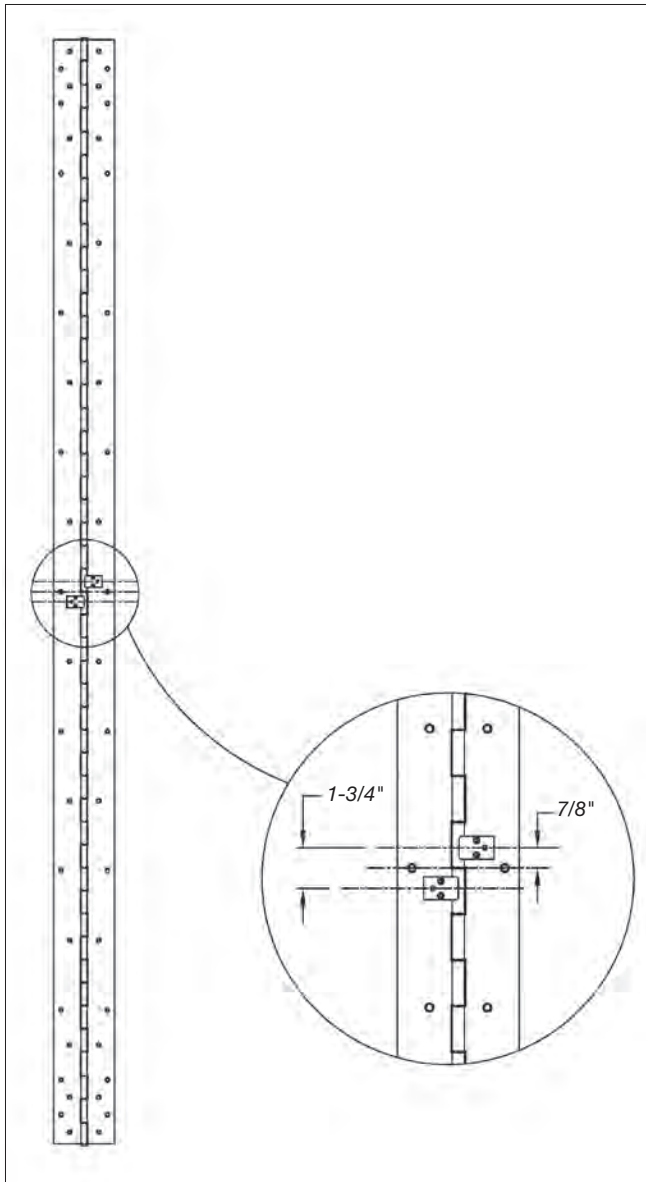
Example: SL300 83" SS, CTP-VD 39-3/8" from top of hinge to centerline, LH.

AVAILABILITY: Available on pin & barrel hinge models SL200, SL300, SL303, SL305, SL306, SL315 and SL3500.

LEAD TIME: Contact your SELECT representative.

WARRANTY: 5 years on electrical components.

IMPORTANT: SELECT Products Limited does not recommend preparing door and frame for CTP-VD before receipt of hinge. If door and frame must be prepared before receipt of hinge, contact factory for special template.



PREP: SELECT pin & barrel continuous hinges can be prepared for concealed electric through-wires to provide continuous current. 28 gauge through-wires with ElectroLYNX™ connectors available in sets of 4 (EL-4), 8 (EL-8) or 12 (EL-12).

LOCATION: Specify the dimension from the top of the hinge to the EL centerline. Hinge is installed flush with the top of the door.

Refer to the templates in the Concealed Pin & Barrel Hinge section to choose from available EL locations. These templates are also available online at www.SelectHinges.com.

HANDING: Specify the handing of each door requiring the EL.

ORDER: Use suffix "EL-4", "EL-8" or "EL-12" (depending on number of wires required). Specify location and handing. Only one location is required, whether 4, 8 or 12 wires.

Example: SL300 83" SS, EL-4 41-9/16" from top of hinge to centerline, LH.

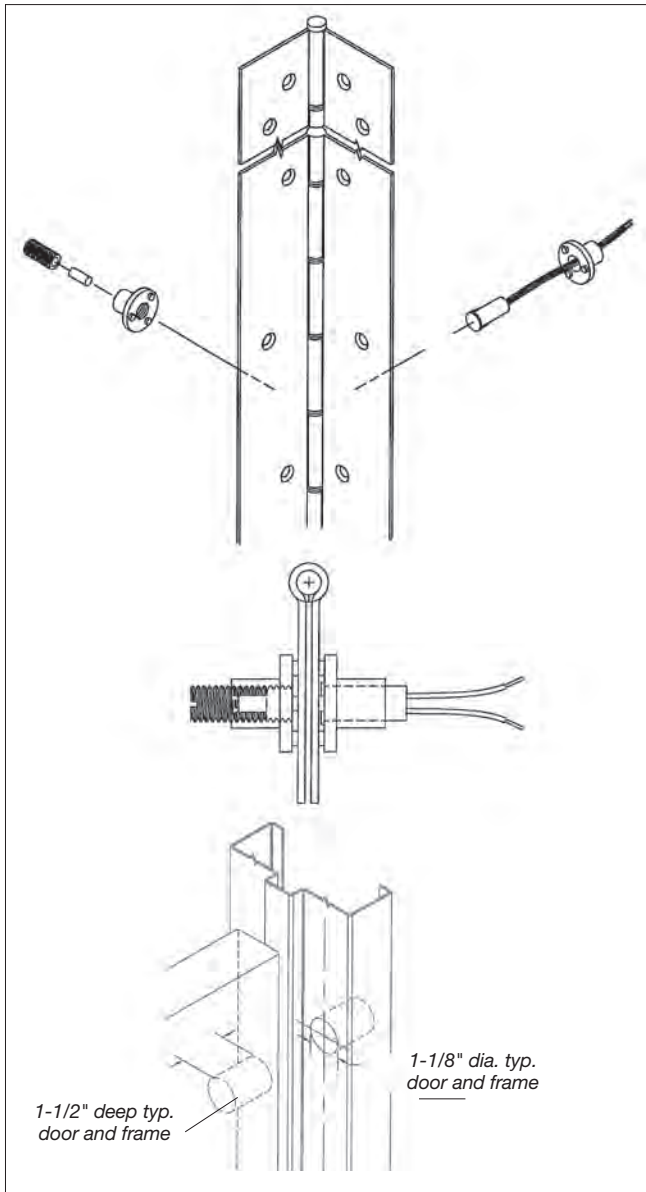
AVAILABILITY: Available on pin & barrel hinge models SL200, SL300, SL305, SL315 and SL3500. NOT AVAILABLE on raised barrel applications.

LEAD TIME: Contact your SELECT representative.

WARRANTY: 5 years on electrical components.

IMPORTANT: SELECT Products Limited does not recommend preparing door and frame for EL before receipt of hinge. If door and frame must be prepared before receipt of hinge, contact factory for special template.

AMS (Adjustable Concealed Monitor Switch)



PREP: SELECT pin & barrel continuous hinges can be prepared for the adjustable concealed monitor switch. Rigid welded assembly gives you the ability to adjust the AMS to work with all applications.

LOCATION: Standard locations from top of hinge to centerline of AMS are as follows:

- 79" hinge = 35-3/8"
- 83" hinge = 37-9/16"
- 85" hinge = 38-1/2"
- 95" hinge = 43-1/2"

For custom locations, specify centerline dimension from top of hinge. Hinge is installed flush with the top of the door.

Refer to the templates in the Concealed Pin & Barrel Hinge section. These templates are also available online at www.SelectHinges.com.

HANDING: Specify the handing of each door requiring the AMS.

ORDER: Use suffix "AMS," plus the location and handing.

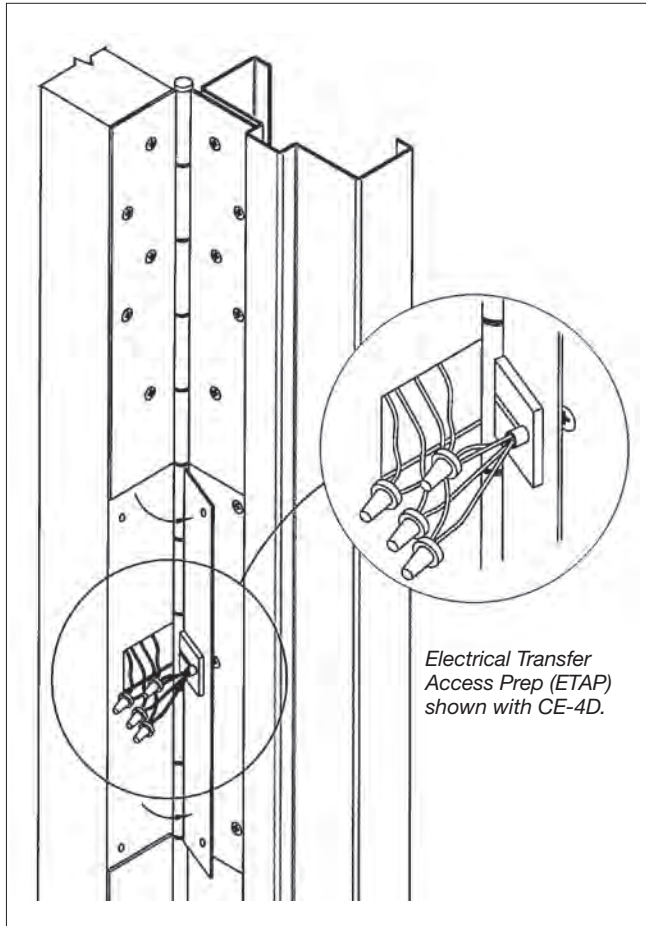
Example: SL300 83" SS, AMS 35-3/8" from top of hinge to centerline, LH.

AVAILABILITY: Available on pin & barrel hinge models SL200, SL300, SL305, SL315 and SL3500. NOT AVAILABLE on powder coat finishes.

LEAD TIME: Contact your SELECT representative.

WARRANTY: 5 years on electrical components.

IMPORTANT: SELECT Products Limited does not recommend preparing door and frame for AMS before receipt of hinge. If door and frame must be prepared before receipt of hinge, contact factory for special template.



PREP: SELECT pin & barrel continuous hinges can be prepared with hinge leaf panels to allow access to electrical components.

LOCATION: Panel is approximately 16" in length. Dimensions will differ depending on the electrical components requested. Hinges are installed flush with the top of the door.

HANDING: Specify the handing of each door requiring the ETAP.

ORDER: Use suffix "ETAP" after designating chosen electrical prep and its location. Specify handing.

Example: SL300 83" SS, CE-4D 40-11/16" from top of hinge to centerline, ETAP, LH.

AVAILABILITY: Available on pin & barrel hinge models SL200, SL300, SL305, SL315 and SL3500.

LEAD TIME: Contact your SELECT representative.

WARRANTY: 5 years on electrical components.

IMPORTANT: SELECT Products Limited does not recommend preparing door and frame for ETAP before receipt of hinge. If door and frame must be prepared before receipt of hinge, contact factory for special template.



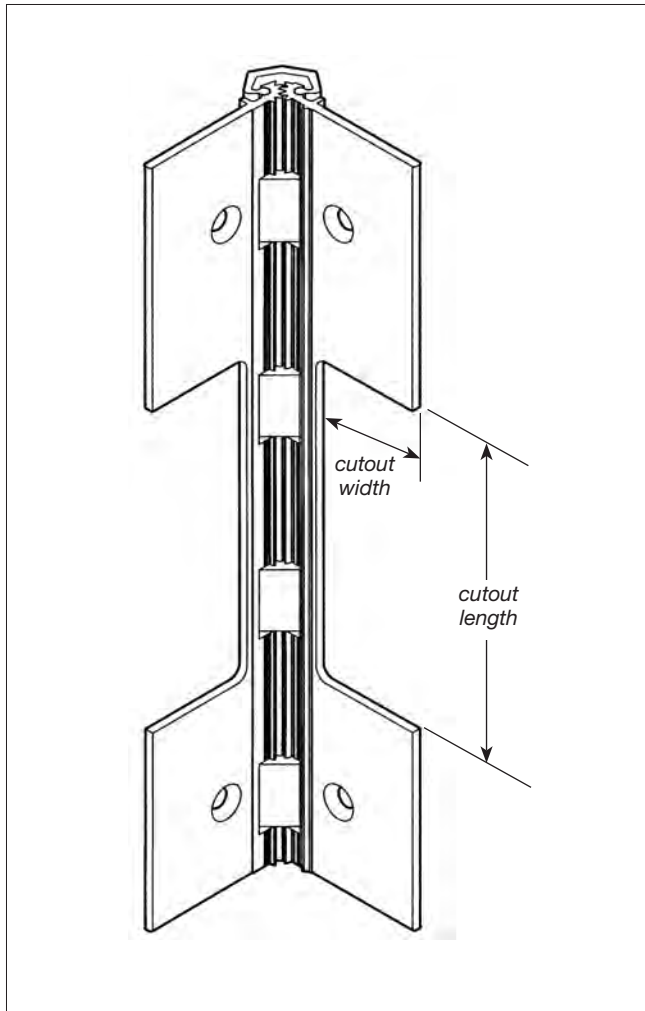
NON-ELECTRIC PREPS

NON-ELECTRIC PREPS

NON-ELECTRIC PREPS



NON-ELECTRIC PREPS



Cutout to expose Fire Labels

PREP: SELECT geared continuous hinges can be prepared with a cutout to expose fire labels on doors and/or frames. Please see Fire Label Cutout order form on following page.

LOCATION: Specify cutout length and width as well as the dimension from the top of the hinge to the centerline of the cutout (see illustration at left). Hinge is installed flush with the top of the door.

Refer to the templates in the Concealed or Half Surface Geared Hinge sections to avoid specifying a cutout location that cuts through fastener holes. These templates are also available online at www.selecthinges.com.

HANDING: Specify the handing of each door requiring the Fire Label Cutout. Handing not required on SL11 and SL27.

ORDER: Use suffix "Fire Label Cutout," plus the dimensions and handing (if required).

Example: SL24 HD600 83" Clear Fire Label Cutout: 4" long, 1½" wide, 41" from top of hinge to centerline, RH.

AVAILABILITY: Available on geared hinge models SL11, SL12, SL14, SL18, SL24, SL26, SL27, SL31, SL40, SL41, SL44, SL48, SL52, SL53, SL54 and SL84. Engineering approval is required.

LEAD TIME: 48 hours (on most orders).

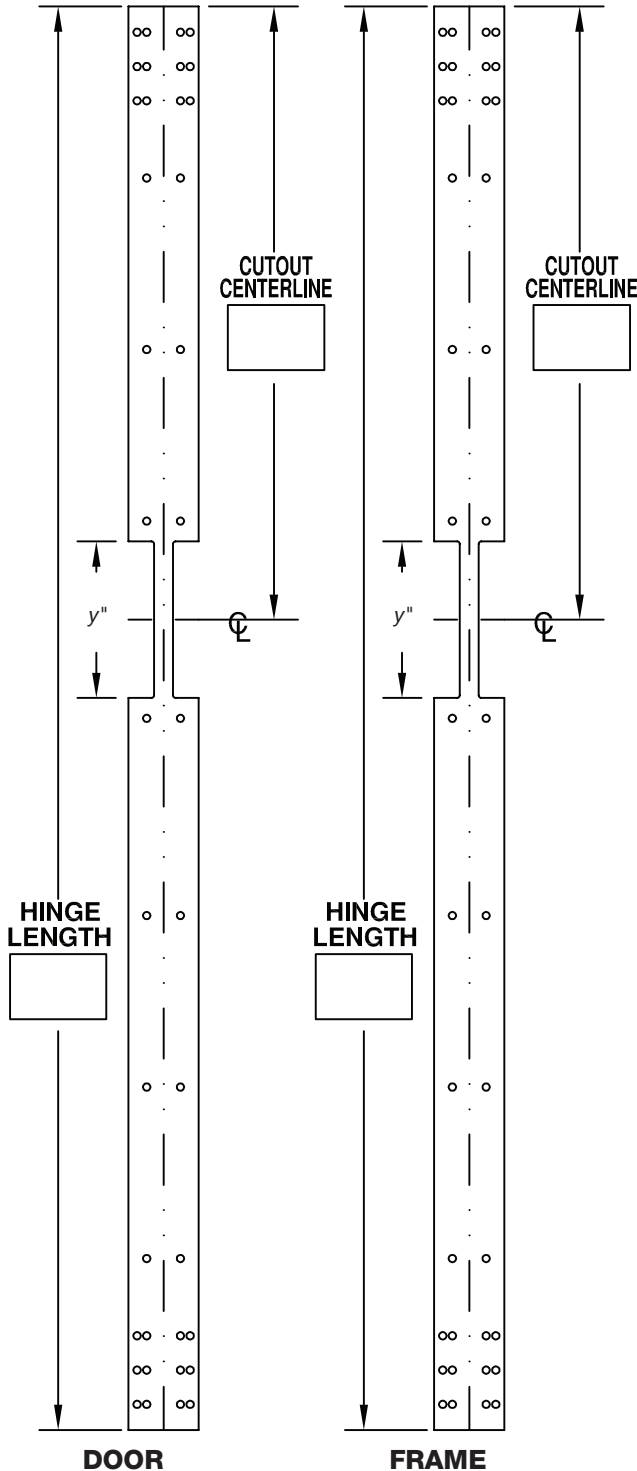
IMPORTANT: SELECT Products Limited does not recommend preparing door and frame for Fire Label Cutout before receipt of hinge. If door and frame must be prepared before receipt of hinge, contact factory for special template.

Fire Label Cutout Template

FILL OUT AND RETURN THIS FORM TO:
 SELECT Products Limited 800-423-7107 customerservice@select-hinges.com

HINGE MODEL #: _____

SPECIFY DIMENSIONS IN BOXES:



DOOR LEAF CUTOUT DIMENSIONS

WIDTH (x''): _____

LENGTH (y''): _____

FRAME LEAF CUTOUT DIMENSIONS

WIDTH (x''): _____

LENGTH (y''): _____

CUTOUT SHAPE: (MATCH EPT MOUNTING FLANGE)



Round end



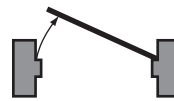
Square end

CUTOUT LOCATION:

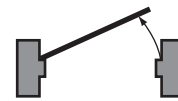
Door leaf

Frame leaf

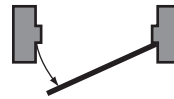
HANDING: (FROM KEYED SIDE)



Right hand



Left hand



Right hand reverse



Left hand reverse

COMPANY: _____

APPROVED BY: _____

DATE: _____

P.O. NUMBER: _____

FIRE LABEL CUTOUT

Edge Guard

SL308



Polymer TIPIT® Hospital Tips

Full Surface



Concealed



Metal TIPIT® Hospital Tips

Full Surface-Metal



Concealed-Metal



ACCESSORIES



PART NUMBER INTERCHANGE

SELECT MODELS	MARKAR	HAGER	PEMKO	MCKINNEY	STANLEY	ABH	IVES
SL308	EG-308		SDEG		EG2/2B	A528F	

No equivalent hinge available from this manufacturer.

INSTALLATION INSTRUCTIONS

Continuous Edge Guard

SL308



PRODUCT MUST BE INSTALLED ACCORDING TO ALL APPLICABLE BUILDING AND LIFE SAFETY CODES

All holes in door and frame must be drilled correctly and fasteners properly installed. Failure to use fasteners supplied by Select Products Limited will void UL or WHI fire rated listing.

Important Warranty Information:

The following actions will void any warranty, expressed or implied:

- Failure to install the hinge according to the manufacturer's specifications and requirements. (for more information, visit selecthingerequirements.com)
- Use of fasteners other than those supplied with the hinge.
- Unauthorized field modifications, including alteration of the original finish or painting the hinge.

1. Door Preparation

A. Place edge guard on edge of door. Position top of edge guard so that it is flush with top of door (Fig. 1).

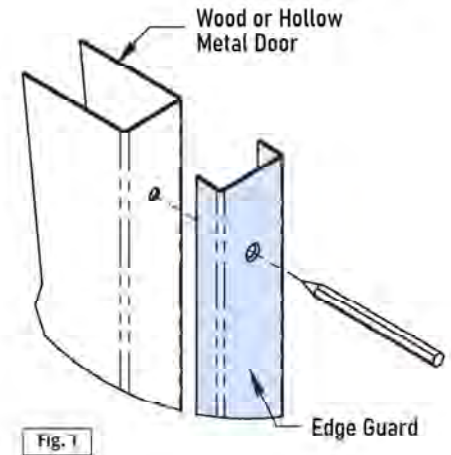
B. Mark and center punch each hole on door with edge guard held firmly in place. The use of the center punch can help center the hole so that the fasteners will enter straight. Remove edge guard from door. Prepare to drill holes.

C. Drilling Doors:

Non Adjustable Edge Guard

Wood Doors: Drill all holes using a 5/32" drill bit.

Hollow Metal Doors: Drill all holes using a #16 drill bit. If hollow metal door is reinforced, thread all holes with 12-24 tap.



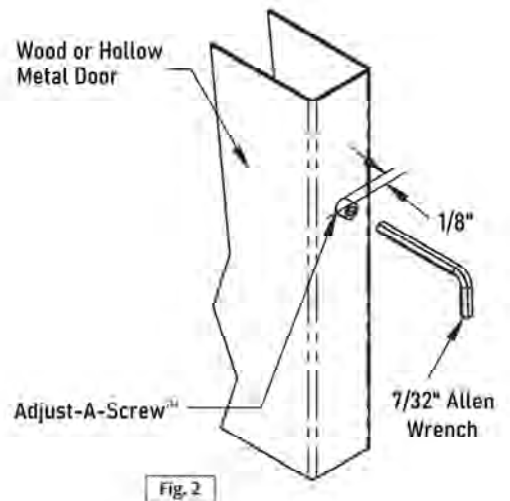
Optional Adjustable Edge Guard (Adjust-A-Screw™ are needed)

Wood Doors:

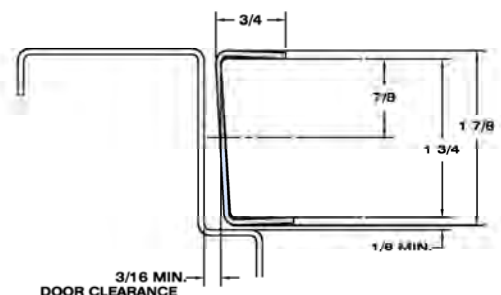
1. Drill all holes using a 5/32" drill bit then enlarge holes to 5/16" with a minimum depth of 1/2".
2. Insert Adjust-A-Screws (Hex Head 3/8-16 External Thread, #10-32 Internal thread (M26-0031-01) into every hole.
3. Place a 7/32" Allen wrench in opening of Adjust-A-Screw and turn Adjust-A-Screw into hole while keeping screw properly aligned (Fig. 2).
4. Drive all Adjust-A-Screws in until approximately 1/8" from edge of door. (*Adjust-A-Screw will self-tap*)

Hollow Metal Doors:

1. Drill all holes using a #16 drill bit then enlarge holes with a 5/16" drill bit.
2. Thread all holes with 3/8-16 tap.
3. Insert Adjust-A-Screws into every hole.
4. Place a 7/32" Allen wrench in opening of Adjust-A-Screw and turn Adjust-A-Screw into hole while keeping screw properly aligned (Fig. 2).
5. Drive all Adjust-A-Screws in until approximately 1/8" from edge of door.



Note: It is not necessary to tap holes in wood doors since Adjust-A-Screws cut their own threads. Do not be concerned with a tight fit. Adjust-A-Screws are designed for a tight friction fit in tapped holes so they will not turn when attachment screw is being tightened. If Adjust-A-Screw turns too freely, apply Loctite™ to threads during installation.



Hinge Placement and Clearance Template

2. Installing Edge Guard

Non Adjustable (Fig 3)

Wood: Attach Edge Guard to door using #12-8 x 1-1/2" Flat Head Undercut Wood Screws

Hollow Metal: Attach Edge Guard to door using #12-24 x 11/16" Flat Head Undercut Self-Drilling Screws

Adjustable Hinge (Fig 4)

Wood & Hollow Metal: Attach Edge Guard to door using #10-32 x 3/4" Flat Head Undercut Machine Screws

*Install top & bottom screws first, then close door to check alignment.
See Special Note below.*

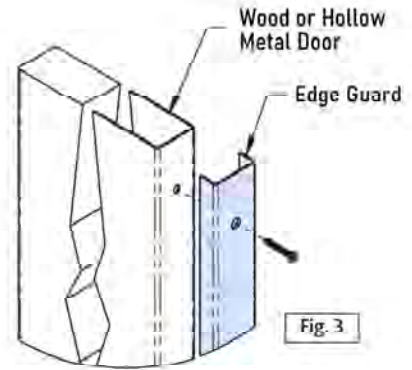


Fig. 3

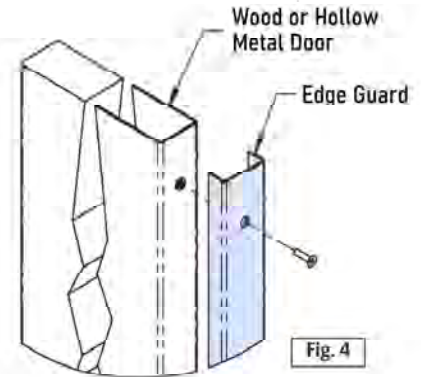


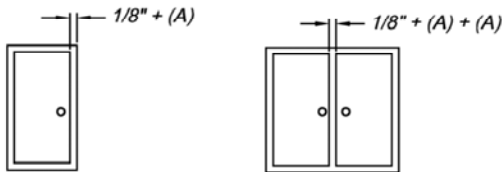
Fig. 4

Special Note: If clearance is sufficient, install and tighten remaining screws into Adjust-A-Screws. If edge guard requires adjustment for proper clearance, make this adjustment with two screws installed without removing edge guard. Remove top screw and insert Allen wrench through hole into Adjust-A-Screw. Turn Adjust-A-Screw in direction desired for adjustment. One full turn of Allen wrench is equal to 1/16". Reinstall screw. Adjust bottom Adjust-A-Screw in same manner. Close door to verify proper clearance in opening. The balance of Adjust-A-Screw should be adjusted in same manner until all are resting firmly against inside face of edge guard. Then install and tighten remaining machine screws.

Model SL308

Standard "Non-Adjustable" application clearances

Clearance (A)	Total Under-Sizing Required	
	Single Door	Pair of Doors
1/16"	3/16"	1/4"

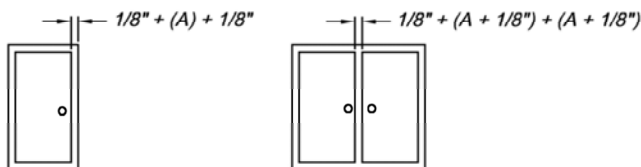


Note: In a stand-alone application, where the SL308 is used on a pair of doors while the opposite door contains no edge guard, the TOTAL UNDER-SIZING FOR THE PAIR OF DOORS WOULD BE 3/16".

Model SL308

Standard "Adjustable" application clearances

Clearance (A)	Total Under-Sizing Required	
	Single Door	Pair of Doors
1/16"	5/16"	1/2"



Note: In a stand-alone application, where the SL308 is used on a pair of doors while the opposite door contains no edge guard, the TOTAL UNDER-SIZING FOR THE PAIR OF DOORS WOULD BE 5/16".

NOTE: Proper door reinforcement is required for adjustable feature.

STANDARD HARDWARE



#12-24 X 11/16" FLAT HEAD UNDERCUT SELF-DRILLING SCREW (TKS1267SP10SS)

OPTIONAL HARDWARE AVAILABLE UPON REQUEST



#12-8 X 1-1/2" FLAT HEAD UNDERCUT WOOD SCREW (PBS12150SP10SS)

ADJUSTABILITY HARDWARE



#10-32 X 3/4" FLAT HEAD UNDERCUT MACHINE SCREW (MS10075SS)

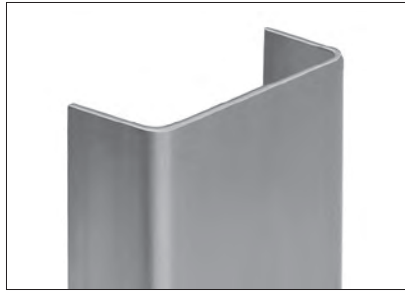


1-3/8" ADJUST-A-SCREW™ (M26-0031-01)

SECURITY SCREWPACKS M91-0005-630, M91-0070-630



3258 Stadium Park Way
Kalamazoo, MI 49009
PH: 800-423-1174
Fax: 800-423-7107
www.select-hinges.com



- Stainless steel
- Lock-side door edge protector
- Can reduce gap between pairs of doors
- Universal Adjusta-Screw™ fasteners (right-hand thread) available at extra cost
- Specify square or beveled door edge
- For 1-3/4" doors

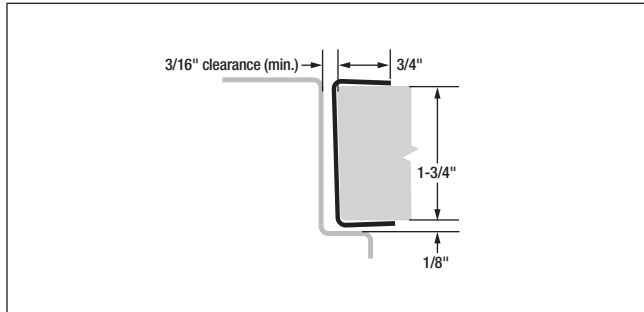
SL308
Continuous Edge Guard



NOTES:

A series of horizontal yellow lines providing a space for handwritten notes.

SL308 Edge Guard



MATERIAL: 16 gauge stainless steel.

LENGTHS: 79", 83", 85", 95" and 119" lengths standard for nominal door heights. Custom lengths are available.

FINISH: US32D satin stainless steel (630).

FASTENERS: #10 x 1-1/4" 304SS Phillips flathead undercut sheet metal screws are provided as a standard pack. Adjusta-Screw™ fasteners optional at extra cost.

ORDER: Specify edge guard length. Specify square or beveled door edge.

SL308 EDGE GUARD SCREW COUNT	
HINGE LENGTH	DOOR SCREWS
79"	7
83"	8
85"	8
95"	9
119"	11

SPECIFICATIONS

SL308 Edge Guard



SELECT ADVANTAGES



CORROSION-RESISTANT STAINLESS STEEL

Stainless steel construction creates a tough, highly secure opening.



VARIETY OF FINISHES

Available in polished, brushed and painted finishes to match, contrast or accent your building's design.



3-HR. FIRE RATING

Fire-rated out of the package.
No extra parts to buy or install.
No liability worries.



ADJUSTA-SCREW™ FASTENERS

Remedy out-of-square doors and frames easily. Correct fit variances up to 3/8" along full length of door. Available at extra cost.



Black polymer TIPIT® CB



Gray polymer TIPIT® CG



Metal TIPIT® CM



Black polymer TIPIT® LB

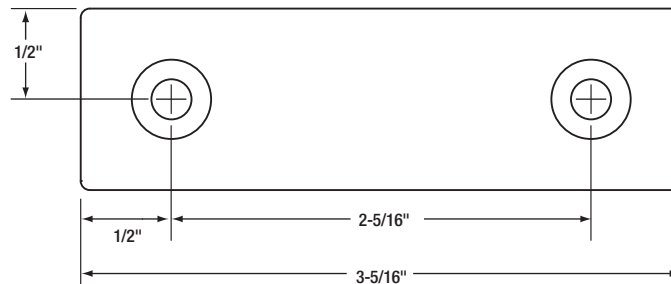
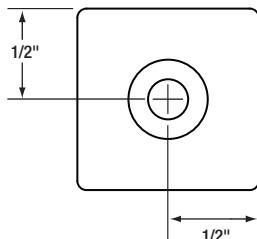
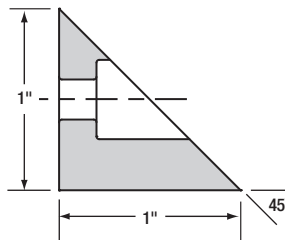
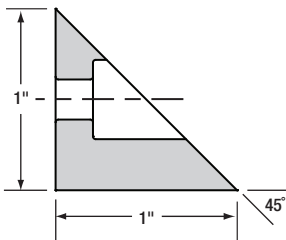


Gray polymer TIPIT® LG



Metal TIPIT® LM

- Patented design
- Prevents objects from being attached to top of hinge (ligature-resistant)
- Durable aluminum or high-tech polymer
- Securely fastens to door frame header
- Works for retrofit or new applications
- Fits most other brands of geared continuous hinges
- Includes #10 Torx® SST security screw(s)
- Metal TIPIT® LM and SL57 combination meets patient safety standards.
Visit the OMH link below:
www.omh.ny.gov/omhweb/patient_safety_standards/guide.pdf



TIPIT®

Ligature-Resistant Hospital Tip

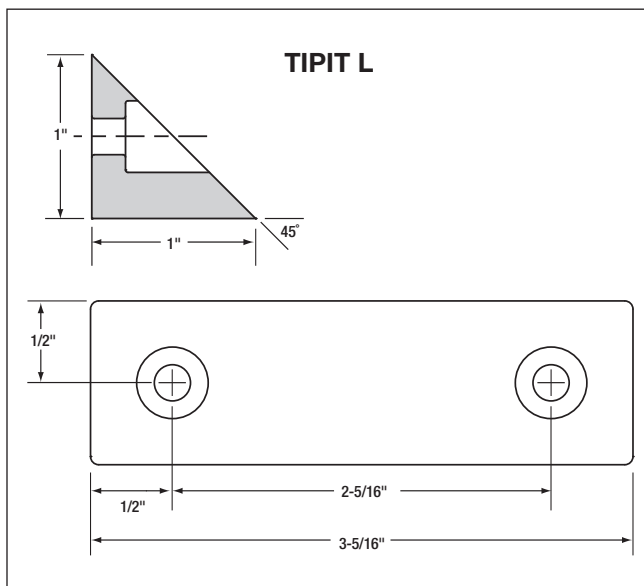
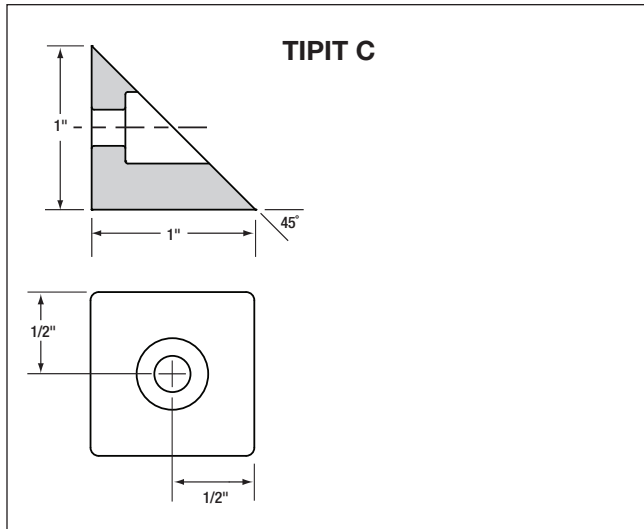


FOR USE IN:

- Hospitals
- Correctional facilities
- Schools
- Other institutions

NOTES:

TIPIT® Hospital Tip



APPLICATION: The patented SELECT TIPIT® works with new or existing continuous hinges to make rooms safer. The TIPIT will deter people from harming themselves by hanging objects from the hinge.

INSTALLATION: SELECT TIPIT Hospital Tips are mounted on the surface of the frame, above continuous hinges.

MATERIAL: Durable aluminum or high-tech polymer.

SIZE: TIPIT C = 1" x 1" x 1". TIPIT L = 3-5/16" x 1" x 1".

COLOR: Metal TIPITs have an aluminum finish. For polymer TIPITs, choose Gray (for use with clear anodized hinges) or Black (for use with dark bronze anodized hinges).

FASTENERS: Includes #10 Torx® SST security screw(s).

ORDER: If ordering only the TIPIT for a hinge already in the field, simply specify TIPIT C or TIPIT L, then the color. If ordering the TIPIT with a hinge, specify the full description of the hinge first, TIPIT C or TIPIT L as a suffix, then the color. Then specify TIPIT PREP as another suffix if necessary. See details below.

- Specify TIPIT C for use with the SL11, SL12, SL14, SL18, SL24, SL26, SL27, SL31, SL38, SL44, SL48 and SL84 and most other brands of concealed continuous geared hinges (excluding the SL71 and other safety-type concealed hinges). Includes small TIPIT and (1) #10 Torx® security screw.

- Specify TIPIT L for use with the SL21, SL41, SL52, SL53, SL54, SL57, SL71 and SL77 and most other brands of full surface, half surface, half mortise, swing clear and concealed safety hinges. Includes large TIPIT and (4) #10 Torx® security screws.

- Hinge preparation for use of TIPIT L with SL21, SL53, SL54 and SL57 hinges: Specify TIPIT PREP for factory preparation of door leaf covers for field installation of TIPIT L.

NOTE: Order TIPIT L separately.

NOTE: Not necessary for SL41 swing clear, SL52 half mortise or SL71 safety hinges.

TIPIT® SCREW COUNT

TIPIT C	TIPIT L
1	4

Metal TIPIT® L and SL57 combination receives OMH Acceptance

SELECT's metal TIPIT® L, paired with our SL57 full surface hinge, earned the New York State Office of Mental Health Patient Safety Standards, Materials and Systems Guidelines seal of acceptance for ligature resistance. This TIPIT/SL57 combination is also included in the Facility Guidelines Institute (FGI) Behavioral Health Design Guide.

SPECIFICATIONS

Ligature-Resistant TIPIT®



The **SELECT** ligature-resistant TIPIT® can immediately add safety to doorways in both new and retrofit applications

FOR USE IN HOSPITALS, CORRECTIONAL FACILITIES, SCHOOLS AND OTHER INSTITUTIONS

SELECT's patented, ligature-resistant TIPIT® keeps patients safer. Whether as a retrofit application for existing hinges or in new construction, the TIPIT will deter patients or inmates from harming themselves by hanging objects from the hinge.



Black polymer TIPIT® C on Dark Bronze concealed hinge.



Gray polymer TIPIT® C on Clear anodized concealed hinge.



Metal TIPIT® C on Clear anodized concealed hinge.

TIPIT® C

- For new construction or retrofit applications.
- Mounts on surface of frame above most brands of concealed continuous geared hinges.
- Fits SELECT hinge models SL11, SL12, SL14, SL18, SL24, SL26, SL27, SL31, SL38, SL44, SL48 and SL84.

- Includes a small TIPIT® and one (1) #10 Torx® security screw.
- Order hinge, and specify TIPIT color/material:
 - Black polymer [TIPIT CB]
 - Gray polymer [TIPIT CG]
 - Metal [TIPIT CM]

NOTE: Not for use with concealed safety hinges (SL71).



Black polymer TIPIT® L on Dark Bronze SL57 full surface hinge.



Gray polymer TIPIT® L on Clear anodized SL57 full surface hinge.



Metal TIPIT® L on Clear anodized SL57 full surface hinge.

TIPIT® L

- For new construction or retrofit applications.
- Mounts on surface of frame above most brands of full surface, half surface, half mortise, swing clear and concealed safety geared continuous hinges.
- Fits SELECT hinge models SL21, SL41, SL52, SL53, SL54, SL57, SL71 and SL77.
- Includes a large TIPIT® and four (4) #10 Torx® security screws.
- Order hinge; specify TIPIT color/material:
 - Black polymer [TIPIT LB]
 - Gray polymer [TIPIT LG]
 - Metal [TIPIT LM]

TIPIT® L Hinge Prep

- Factory preparation of door leaf covers for field installation of #10 Torx® security screws.
- Available on SL21 and SL57 full surface hinges, and SL53, SL54 and SL77 half surface hinges.
- Order hinge, and specify [TIPIT PREP].
- Order TIPIT® L separately.

NOTE: TIPIT PREP is not necessary for SL41 swing clear hinges, SL52 half mortise hinges or SL71 concealed safety hinges.

Metal TIPIT® L and SL57 combination receives OMH Acceptance

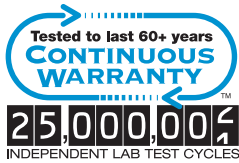
SELECT's metal TIPIT® L, paired with our SL57 full surface hinge, earned the New York State Office of Mental Health Patient Safety Standards, Materials and Systems Guidelines seal of acceptance for ligature resistance.

This TIPIT/SL57 combination is also included in the Facility Guidelines Institute (FGI) Behavioral Health Design Guide.



SELECT HINGES®

SELECT Products Limited



3258 Stadium Park Way | Kalamazoo, MI 49009 | Ph: 800-423-1174 | Fax: 800-423-7107 | www.select-hinges.com